



Driver & Vehicle
Standards
Agency

Heavy Goods Vehicle Inspection Manual

consolidated edition 2013

Heavy Goods Vehicle Revision Record

Section Number	Section Title	Description of Change	Revision Date	Revision Number
	Consolidated 2013 HGV Inspection Manual	New consolidated 2012 version	01/01/2013	1.
	Interpretation of Terms used in the Manual	Page 3 First used date paragraph amended to include trailers.	01/01/2013	2.
14	Spray Suppression, Wings and Wheel Arches	Page 3 bulleted list for raising flap height from 200mm to 300mm has been amended. Bullet one the words "or trailer" have been added.	01/01/2013	3.
22	Mirrors and Indirect Vision Devices	Page 2 first para graph the word "class" removed. Page 3 MOI and RfF 2 the word "a" has been replaced with the words "any required"	01/01/2013	4.
26	Speedometer/Tachograph	Page 2 paragraph for vehicles not requiring a tachograph which have a tachograph fitted used as a speedometer has been amended from: "Check installation/calibration plaque for presence and condition, and the date of calibration is clearly visible." to read Only where the tachograph is marked in KPH alone, will you be required to check the installation/calibration plaque for presence and condition, and the date of calibration is clearly visible.	01/01/2013	5.
62	Markers and reflectors	Pages 7 and 11 note added to each diagram containing both conspicuity and rear markers "Where both conspicuity and rear markers are fitted, see rear markers application".	01/01/2013	6.
63	Lamps	Page 4, lamp requirements summary table, has the information on Main beam lamps amended. The words "No closer to the side than the dipped beam lamp Being a matched pair" have been removed from the column for maximum distance from the side.	01/01/2013	7.
71	Service Brake Performance	Page 1, electric/hybrid vehicle information for vehicles requiring decelerometer testing has been updated. Page 2, second sentence in Locked Wheels paragraph has been reworded as data cards are no longer being produced.	01/01/2013	8.

Section Number	Section Title	Description of Change	Revision Date	Revision Number
	Standards for Prohibition	IM38 - Vacuum assistance is not working – this now has a single asterisk.	20/03/2013	9.
01	Registration Plate	RfF 1 and 2 font now in black.	20/03/2013	10.
03	03 Seat Belts & Supplementary Restraint Systems	RfF 7, 8 and 9 font now in black.	20/03/2013	11.
18	Seats	RfF 2 and 3 font now in black.	20/03/2013	12.
22	Mirrors and Indirect Vision Devices	RfF 1 to 4 references to indirect vision devices and cameras font now in black. Note added to page two “ RfF 2 will not apply to cameras replacing front and or close proximity mirrors fitted less than 2 metres from the ground where the camera is hidden with in the body contour.”	20/03/2013	13.
26	Speedometer/Tachograph	RfF 3d font now in black.	20/03/2013	14.
36	Hand Lever Operating Mechanical Brakes	RfF 1i and j font now in black.	20/03/2013	15.
37	Service Brake Pedal	RfF 2c and d font now in black.	20/03/2013	16.
38	Service Brake Operation	RfF 5 (ESC reference), 6 and 7 font now in black. RfF 3 now has only a single asterisk.	20/03/2013	17.
42	Electrical Wiring and Equipment	RfF 4 font now in black.	20/03/2013	18.
48	Suspension	RfF 1j and k font now in black.	20/03/2013	19.
54	Steering	RfF 1 d, i, j and k font now in black. RfF 2k, t, u and v font now in black.	20/03/2013	20.
58	Additional Braking Devices	RfF 1 font now in black.	20/03/2013	21.
59	Brake Systems and Components	RfF 1 e font now in black. RfF 5g, h and l font now in black. RfF 6 font now in black.	20/03/2013	22.
63	Lamps	RfF 4e and 5 font now in black.	20/03/2013	23.
	Front cover	New corporate logo added	01/07/2013	24.
	About this manual	Page 5, Training information updated	01/07/2013	25.

Section Number	Section Title	Description of Change	Revision Date	Revision Number
01	Registration Plate	Application amended to clarify section only applies to registered vehicles.	01/07/2013	26.
14	Spray Suppression, Wings and Wheel Arches	Note "It is important to note however that this does not apply to spray suppression and therefore vehicles subject to the spray suppression requirements must have complete wings." has been amended and includes spray suppression in the exemption.	01/07/2013	27.
38	Service Brake Operation	Page 3 paragraphh ""If a trailer does not have a warning light"... "Failure 5" amended to "failure to 5a." Page 3 and 4 Information for ABS, ABS/EBS & EBS/ESC requirements reworded for clarity and ABS warning lamp procedure removed from page 4 Page 6 MOI and RfF 5, 6 & 7 wording amended for clarity now MOI & RfF 5, 6, 7 and 8.	01/07/2013	28.
53	Axles, Stub Axles and Wheel Bearings	Page 1 application - Mercedes Sprinter information updated. Mercedes sprinters play and radial movement acceptable up to 3mm.	01/07/2013	29.
58	Additional Braking devices	Further information added to the application section: <ul style="list-style-type: none"> • If the device has been removed and it is mandatory this will be a reason for failure, if the device is not mandatory the operator should be informed to complete a VTG10 notifiable alteration form. Where an exhaust brake operating cylinder and lever are completely removed, the housing containing the butterfly may be retained with the butterfly fixed in the open position. • The check of operation is made by visual assessment, failure is justified only when it is obvious that a device is inoperative i.e. a disconnected linkage. • Any inoperative device will be a reason for failure irrespective of whether it is mandatory or not. 	01/07/2013	30.
62	Markers and Reflectors	Pages 5 to 12 updated to incorporate changes to the standards to apply for conspicuity markings including a note on page 8 which gives guidance on cab markings (50mm high by 50mm wide) and any gaps between the cab and body markings.	01/07/2013	31.
66	Direction Indicators and Hazard Warning Lamps	Page 2 – MOI and RfF 1b amended the words "and that it is visible to the rear" removed from MOI and "or not visible to the rear." removed from RfF.	01/07/2013	32.

Section Number	Section Title	Description of Change	Revision Date	Revision Number
38	Service Brake Operation	Pages 3 and 4 – minor update to titles for ABS, ABS/EBS and ABS/EBS/ESC paragraphs.	01/10/2013	33.
53	Axles, Stub Axles and Wheel Bearings	Page 1 & 2 application – MOI and RfF sections reworded to cater for option to jack.	01/10/2013	34.
54	Steering	Page 1 application sections reworded to cater for option to jack.	01/10/2013	35.
05	Exhaust Emissions	Page 4 MOI and RfF 3 added to includes checks for presence of emission control systems where fitted as standard.	16/02/2014	36.
	Front cover page	Corporate logo updated	01/10/2014	37.
	Foreword	VOSA updated to DVSA and information re production of hard copy documents removed.	01/10/2014	38.
	About this Manual	Pages 2 and 5 updated VOSA to DVSA	01/10/2014	39.
	Standards for Prohibition Issue at Annual Test	Page 4 - RfF 4a, b and c amended to twin asterisks. Page 6 - IM71 RfF 2di – has been amended to a single asterisk.	01/10/2014	40.
03	Seat Belts & Supplementary Restraint Systems	Pages 2 and 3 content rearranged in order to add clarification note on page 2 “ Where a belt is fitted with no corresponding seat or if there is a buckle/stalk but no corresponding belt, it is NOT to be considered a seat belt for the purpose of this inspection.”	01/10/2014	41.
08	Condition of Tyres	Page 2 VOSA updated to DVSA	01/10/2014	42.
14	Spray Suppression Wings and Wheel Arches	Page 11 figure 5 updated – rear flap height maximum increased from 200 to 300mm to comply with note on page 3 “any axle where the radial dimension to the lower edge of the valancing, or wheel guard, is not greater than the radius of the tyre”	01/10/2014	43.
26	Speedometer/Tachograph	Page 3 application section – note added – “ Where a print out from a digital tachograph cannot be obtained initially (because of a jammed or depleted roll) the presenter should be given the opportunity to rectify this before leaving the test station and the use of PRS would not be appropriate if the defect is rectified.”	01/10/2014	44.
33	Speed Limiter	Pages 3 and 4 - VOSA updated to DVSA	01/10/2014	45.

Section Number	Section Title	Description of Change	Revision Date	Revision Number
38	Service Brake Operation	Page 3 – ABS only vehicles first paragraph, clarification for MIL illumination added “(ignition on)” changed to “(ignition or battery master switch on)”. Page 3 – ABS only vehicles second paragraph, note added (On some trailers the trailer warning lamp may be extinguished when the ISO7638 cable is fitted).	01/10/2014	46.
45	Fuel Tanks and System	Page 2 RfF 4a,b and c now have twin asterisks.	01/10/2014	47.
58	Additional Braking devices	Application section note for visual assessment and the check of operation reworded.	01/10/2014	48.
63	Lamps	Page 1 - note added to application “ The rear position lamps are permitted to be reciprocally incorporated with the rear fog lamp providing the positional requirements are met (when the fog lamp is switched on the rear position lamps intensity increases to become the fog lamp).” Page 5 - Rear fog lamp maximum height raised from 1000mm to 1200mm	01/10/2014	49.
71	Service Brake Performance	Page 7 - RfF 2.d.i has been amended to a single asterisks	01/10/2014	50.
	About this Manual	Page 4 updated Vehicle and Operator Services Agency to Driver and Vehicle Standards Agency	01/04/2015	51.
	Interpretation of Terms used in the Manual	Page 7 Type approved note - second paragraph amended to address circumstances where a component or system is claimed to be type approved.	01/04/2015	52.
07	Size and Type of Tyres	Page 1 & 12 updated Vehicle and Operator Services Agency to Driver and Vehicle Standards Agency Page 5 Minor correction to single LI 108 and single LI 132	01/04/2015	53.

Section Number	Section Title	Description of Change	Revision Date	Revision Number
62	Markers and Reflectors	<p>Page 6 & 7, 80% width requirement amended to 70%</p> <p>Page 8, 80% length requirement amended to 70%. Second bullet amended removing "(not including the cab)" and adding measured from 2.4m from the extreme front of the vehicle.</p> <p>Page 8 note added " As an alternative cab marking from using a 50mm X 50mm conspicuity marking within 600mm of the cab front, the cab may be marked using side reflectors with a minimum spacing of 600mm to within 600mm from the front of the cab."</p> <p>Page 9, 80% length requirement amended to 70% and note " Vehicle length excludes the cab but the cab must be marked." Removed.</p> <p>Bullet point added "For trailers total cumulative length will be the full trailer length".</p>	01/04/2015	54.
66	Direction Indicators and Hazard Warning Lamps	Page 1 application section, note added " If more than one bulb or LED is fitted in the lamp at least 50% must work.	01/04/2015	55.
67	Aim of Headlamps	Page 2 RfF 1, 2 and 3 have been revised and the aiming screen image replaced.	01/04/2015	56.
71	Service Brake Performance	<p>Page 4 Note for testing tri axle trailers equipped with Knorr Bremse EBS/ABS amended – word "Unladen" removed and procedure F reworded.</p> <p>Page 4, further information added to note for vehicles with hydrostatic drives - "Prior to roller brake testing any vehicle with hydrostatic drive and a transmission parking brake it may be necessary when the wheels are in the roller set to select neutral, switch off the ignition and restart the vehicle. Engaging this mode will prevent any hydrostatic retardation showing as excessive levels of bind."</p>	01/04/2015	57.
63	Lamps	Application section page 3, "If more than two lamps are fitted..." replaced with " If two or more lamps are fitted.."	01/10/2015	58.
66	Direction Indicators and Hazard Warning Lamps	Application section page 1, "If more than two lamps are fitted..." replaced with " If two or more lamps are fitted.."	01/10/2015	59.
71	Service Brake Performance	Page 7 MOI & RfF 2 the word "Other" has been replaced by "All".	01/10/2015	60.
72	Secondary Brake Performance	<p>Page 1 application amended to apply only to vehicles where the designated secondary is independent of the service brake.</p> <p>Page 1 paragraph for split systems removed and paragraph for alternative secondary options also removed.</p> <p>Page 2 MOI & RfF 2 the word "Other" has been replaced by "All".</p>	01/10/2015	61.

Foreword

Welcome to this new edition of the Heavy Goods Vehicle Inspection Manual. I would first like to acknowledge the members of DVSA staff whose efforts have resulted in this comprehensive reference for annual testing. I hope that they will derive satisfaction from having their work acknowledged.

This edition incorporates changes as a result of the latest testing directive (2010/48) as well as clarification on all test standards enquiries raised since the last edition and will result in fewer occasions when the test standard is unclear. This edition will also be available electronically in an Adobe™ (.pdf) format and be down-loadable from the internet free of charge. This will make it more accessible to industry and enable more frequent updating.

The primary purpose of the Manual is to support DVSA staff in conducting the annual testing of vehicles. Our aim is to provide customers with a consistent testing service with the correct outcome according to the vehicle condition. It will be useful to industry to provide assurance that the service that is being provided is to the published standard and improve the level of accountability that DVSA has to our customers.

The Manual will also be useful to those responsible for the maintenance of large commercial vehicles so that they remain well informed on the current minimum legal standards for roadworthiness. Its publication and ease of availability demonstrates DVSA's ongoing commitment to improving road safety and environmental protection whilst supporting industry to fulfil its obligations to maintain the roadworthiness of vehicles at all times.

Alan Wilson
Head of Testing Schemes Management

About this Manual

Purpose

This manual explains to everyone engaged in the practical work of vehicle examination and maintenance:

- The application of specific relevant requirements.
- The procedures and standards to be used.
- The reasons for failure.

The manual is not a legal interpretation of Regulations, nor does it necessarily lay down standards for rejection elsewhere.

Layout of Inspection Manual

The page layout for each inspection item consists of an application section across the whole width of the page; this section will contain the application criteria and may also contain notes relevant to the inspection. The remainder of the inspection item page(s) will be split between both a Method of Inspection and Reason for Failure columns.

Methods of Inspection

The procedures given here assume that only parts of a vehicle which can readily be seen without dismantling are to be examined. However, it may be necessary to ask the driver to remove wheel embellishers or panels where it is not otherwise possible to inspect safety critical items.

Vehicle combinations will not normally be separated for the purposes of the test although it will be necessary to disconnect and reconnect air lines as directed.

Minimum Standards

It must be emphasised that these are minimum acceptable standards, which do not necessarily allow for further deterioration when the vehicle is in service.

About this Manual

Acceptance For Test

The requirements relating to a Ministry Plate are a condition for accepting the vehicle for test which therefore cannot be started without a satisfactory plate being available.

This does not apply however to trailers presented for their first ever annual test.

Plating documents for these trailers will be issued on successful completion of this "first test".

Other conditions for accepting vehicles for test include:

- A trailer must be accompanied by a suitable drawing vehicle.
- The vehicle chassis number or trailer Ministry identification mark must be permanently fixed to the vehicle in an accessible, easy to read position.
- The vehicle/trailer must be clean enough to allow the component parts to be inspected.
- The vehicle/trailer must not present a health & safety hazard to inspect.
- The vehicle/trailer must be laden as specified in the appointment letter.

If you are in doubt regarding any of the above, it is recommended that you contact your local Driver and Vehicle Standards Agency Test Station or DVSA Contact Centre for advice.

Vehicles normally fitted with permanent bodies and which have had them removed, fall outside the classification of a goods vehicle and should not be accepted for test. This does not include bin carriers, skeletal vehicles for carrying containers or demountable bodied vehicles.

About this Manual

The Inspection

Each inspection has been allocated a number, which is given at the top of the page.

Not all inspection numbers have been allocated.

The requirements of each inspection will be found in Schedule 3 of the Goods Vehicle (Plating and Testing) Regulations.

After The Test

On completion of the test, copies of the smoke test and brake test reports are issued (if applicable) along with either a pass certificate or a refusal to issue a certificate. The refusal will refer to the items considered to be below the minimum standard.

Limits of Wear and Tolerance

Because it is not practicable to lay down limits of wear or tolerance for components of all types of vehicles, the following points should be considered when making an assessment:

- The function of the component and its contribution to the road safety of the vehicle.
- Whether the component has clearly reached the stage where repair, replacement or adjustment is necessary to ensure the road safety of the vehicle.
- Whether the condition of the component appears to contravene the law.

About this Manual

Scope of Inspections

The scope of the inspections in this manual does not cover all the requirements of The Road Vehicles (Construction and Use) Regulations and The Road Vehicles Lighting Regulations.

Dual controls on vehicles will be inspected in the same manner as the primary controls although there will be no separate brake performance check.

Health and Safety

Drivers presenting vehicles for test must follow the instructions given by Driver and Vehicle Standards Agency staff. Radios and telephones must not be used whilst vehicles are undergoing test.

About this Manual

Training

Courses on inspection procedures and standards incorporating the use of this manual are held by The Driver and Vehicle Standards Agency in Avonmouth and Chadderton.

Courses can also be held at operator's premises.

Details of these courses can be obtained from:

Driver & Vehicle Standards Agency
Berkeley House
Croydon Street
Bristol
BS5 0DA

0300 123 9000

email enquiries to: commercial.training@vosa.gov.uk

Interpretation of Terms used in the Manual

Articulated Vehicle

An articulated vehicle is a motor car or heavy motor car with a trailer so attached that part of the trailer is superimposed on the drawing vehicle and, when the trailer is uniformly loaded, not less than 20% of the weight of its load is borne by the drawing vehicle.

Corrosion

The effect of corrosion on the safety of the vehicle depends on:

- Its extent.
- The function of the section on which it has occurred.

A small amount of corrosion on an important part of the vehicle structure can make a vehicle unsafe where it destroys the continuity of the load bearing structure.

On the other hand, heavy corrosion of unimportant sections may have no effect on the vehicle safety.

Corrosion Assessment

The inspection should determine whether excessive corrosion exists first by visual inspection and then by finger and thumb pressure.

If necessary careful scraping or light tapping of the area is permitted.

Corrosion affected heavy gauge metal may be tapped harder than light gauge, but unwarranted force and damage must be avoided.

Interpretation of Terms used in the Manual

Corrosion Failure Criteria

Any part of a load bearing member or load bearing panelling should be rejected if it is weakened by corrosion to the extent that:

- By finger and thumb pressure it does not feel rigid, or
- It crumbles to leave a hole, or
- When tapped there is penetration, or it causes the metal to crumble or disintegrate.

Cracked

A flaw or split in a component.

Damage

When assessing the extent of damage it is important to consider whether the performance of the component/system will be impaired or if the component/system is likely to fail prematurely.

Damage fulfilling either of these criteria is not acceptable and will be a reason for failure.

Deteriorated

This will be a reason for failure if the component or system is weakened to such an extent that it can no longer adequately perform its function.

Distorted

This will be a reason for failure if the component or system is distorted to such an extent that it can no longer adequately perform its function.

Interpretation of Terms used in the Manual

Excessive travel

An abnormal amount of movement which clearly indicates that a component has reached a stage when it requires remedial action to enable it to either:

- a. operate effectively as designed, or
- b. prevent it from reaching the end of its permitted travel, or
- c. prevent it from exceeding manufacturer's known maximum permitted limits

Excessive wear

A component which is worn to such an extent that it is either:

- a. likely to fail, or
- b. clearly not functioning effectively as designed, or
- c. visibly worn beyond manufacturers' known permitted limits, or
- d. likely to affect the operation or condition of another safety related component.

First use dates

Throughout this manual we have used the terms "before" and "from" when referring to first use dates. The term "from" should be regarded to be 'on or after' a certain date. Where there is a first use date quoted for a motor vehicle/trailer this will not normally apply if the vehicle/trailer was built more than 6 months before that date.

Interpretation of Terms used in the Manual

Forward Control Vehicle.

Is a vehicle the configuration of which:

- more than half of the engine length is rearward of the foremost point of the windshield base and;
- the steering wheel hub is in the forward quarter of the vehicle length.

Fouling

This will only be a Reason for Failure if contact of two parts is likely to cause damage to, or restrict the movement of a component.

Fractured/broken

Gap, opening or rupture where separation has taken place.

HEV (Hybrid Electric Vehicle)

A vehicle powered by a power train that consists of both an internal combustion engine and an electrical energy/power storage device.

Inappropriate Repair or Modification

Repairs and modifications to vehicles must be assessed on their merits, taking account of the nature and function of the component.

The main criterion to be used when assessing repairs is whether the repair is obviously likely to adversely affect the roadworthiness of the vehicle. In respect of modifications, the main criterion should be whether the modification has seriously weakened the component.

Interpretation of Terms used in the Manual

Insecure

The term “insecure” is used many times throughout this manual to describe a defective condition. This term should be taken by vehicle inspectors to mean either:

- That a component on the vehicle has relative movement (looseness) either at its fixings or in relation to an associated component where there should be none, or
- That a component is not safely or completely attached either at its fixing or to an associated component.

All components on a vehicle need to be safely attached while it is in use on the road, however, how safe a component needs to be attached depends on its function.

Areas of the vehicle which are considered critical in terms of the ability of the vehicle to endanger the driver, any passengers and other users of the road, can tolerate fewer fixings which are broken, loose, missing or otherwise ineffective than those in a less critical part of the vehicle.

The proportion will depend on factors such as the design of the component etc, but as a general rule, no more than 20% (1 in 5) of the fixing devices should be loose etc. More than this proportion means that the remaining fixing devices could be over-stressed and could therefore fail at any time.

Interpretation of Terms used in the Manual

Examples of critical systems include (this is **not** an exhaustive list):

- steering.
 - brakes.
 - suspension linkages.
 - leaf spring anchors.
 - trailer couplings.
 - live (i.e. moving) transmission components.
 - wheel and hubs.
- } Except those components not subject to heavy loads or forces e.g. power steering reservoirs or brake relay valves.

The proportion suggested above does not apply to:

- components in a critical area or system secured by a **single** fixing device. If this device is loose, broken etc then the component is to be considered insecure.
- components in a critical area or system where detailed instructions are given in the manual (e.g. wheel studs/nuts). In such cases, these instructions must be used in preference.

Components that are not part of a critical system e.g. some body panels can tolerate a higher proportion of their fixings either loose, broken etc. Again the proportion will depend on the design of the component but as a general rule no more than 33% (1 in 3) of the fixing devices should be loose, broken missing or otherwise ineffective.

A component secured by a non-standard temporary means should be judged as if the temporary fixing was not fitted.

Interpretation of Terms used in the Manual

Obligatory

Required to be fitted by law.

Semi-trailer

A trailer which is constructed or adapted to form part of an articulated vehicle.

Trailer

Where the term trailer is used in this manual it refers to all types of trailers and semi-trailers.

Type Approved Vehicle

A vehicle manufactured from 1 October 1982 and first used from 1 April 1983 and has been issued with a Type Approval Certificate of Conformity, a Ministers Approval Certificate or a Type Approval Certificate issued by an EU Member State.

Type Approved

A component or system fitted to a vehicle which has been issued with a Type Approval Certificate or Certificate of Conformity or built to an approval standard which shows that the system or component complies with the requirements of an EU Directive or ECE regulation.

If the presenter claims that the vehicle is fitted with type approved equipment which complies with the requirements of an EC directive and has no documentary evidence, consideration must be given to the following:

- annual test standards should not exceed those of type approval
- does the component or system appear to have been modified, replaced or damaged

Where doubt exists, the benefit should be given to the presenter.

Vehicle

Where the term vehicle is used in the application section of this manual it refers to all types of **motor vehicle**.

Interpretation of Terms used in the Manual

Vehicle Category (Definition used in the Community Directive)

N2: Vehicles used for the carriage of goods and having a maximum mass exceeding 3500 kg but not exceeding 12,000kg.

N3: Vehicles used for the carriage of goods and having a maximum mass exceeding 12,000kg.

O2: Trailers with a maximum mass exceeding 750 kg but not exceeding 3,500kg.

O3: Trailers with a maximum mass exceeding 3,500 kg but not exceeding 10,000kg.

O4: Trailers with a maximum mass exceeding 10,000kg.

List of Inspections

- | | | | |
|----|--|----|---|
| 1 | »Registration Plate | 25 | »Windscreen Washers and Wipers |
| 2 | Not allocated | 26 | »Speedometer/Tachographs |
| 3 | »Seat Belts & Supplementary Restraint Systems | 27 | »Horn |
| 4 | Not allocated | 28 | »Driving Controls |
| 5 | »Exhaust Emissions | 29 | Not allocated |
| 6 | Road Wheels and Hubs | 30 | »Steering Control |
| 7 | Size and Type of Tyres | 31 | Not allocated |
| 8 | Condition of Tyres | 32 | Not allocated |
| 9 | Sideguards, Rear Under-Run Devices and Bumper Bars | 33 | »Speed Limiter |
| 10 | Spare Wheel and Carrier | 34 | »Pressure/Vacuum Warning and Build Up |
| 11 | Vehicle to Trailer Coupling | 35 | Not allocated |
| 12 | Trailer parking and Emergency Brake and Air Line connections | 36 | »Hand Lever Operating Mechanical Brakes |
| 13 | Trailer Landing Legs | 37 | »Service Brake Pedal |
| 14 | Spray Suppression, Wings and Wheel Arches | 38 | Service Brake Operation |
| 15 | »Cab Security | 39 | Hand Operated Brake Control Valves |
| 16 | »Cab Doors | 40 | Not allocated |
| 17 | »Cab Floor and Steps | 41 | Condition of Chassis |
| 18 | »Seats | 42 | Electrical Wiring and Equipment |
| 19 | Security of Body, Containers and crane support legs | 43 | »Engine and Transmission Mountings |
| 20 | Condition of Body | 44 | Oil Leaks |
| 21 | Not allocated | 45 | Fuel Tanks and Systems |
| 22 | »Mirrors and Indirect Vision Devices | 46 | »Exhaust Systems |
| 23 | »Glass and View of the Road | 47 | Not allocated |
| 24 | Not allocated | 48 | Suspension |
| | | 49 | Not allocated |
| | | 50 | Not allocated |
| | | 51 | Not allocated |

List of Inspections

- 52 Not allocated
- 53 Axles, Stub Axles and Wheel Bearings
- 54 Steering Mechanism
- 55 Not allocated
- 56 Not allocated
- 57 Transmission
- 58 Additional Braking Devices
- 59 Brake System and Components
- 60 Not allocated
- 61 Not allocated
- 62 Markers and Reflectors
- 63 Lamps
- 64 Not allocated
- 65 Not allocated
- 66 Direction Indicators and Hazard Warning Lamps
- 67 » Aim of Headlamp
- 68 Not allocated
- 69 Not allocated
- 70 Not allocated
- 71 Service Brake Performance
- 72 » Secondary Brake Performance
- 73 Parking Brake Performance
- 74 Other dangerous defects

» Inspection does not apply to trailers

Standards for Prohibition Issue at Annual Test

This provides a standard for the issue of Prohibition Notices where serious defects are observed during statutory tests.

The aim of the policy is to:

- Protect the public from vehicles returning from annual test where extremely serious defects have been observed.
- Provide information about such occurrences to the enforcement wing of the organisation and to Traffic Commissioners.
- Improve the consistency of the treatment of operators.
- Let operators know the rules so that they know and understand the standards for prohibition issue at annual test.
- Preserve a balance between providing a flexible, customer focused, testing service and providing the general public with protection from loss or injury from vehicles returning from test with serious roadworthiness defects.

The approach, in principle, is to apply the immediate prohibition criteria in the Categorisation of Defects to a core of safety critical items.

Note:

Where a Reason for Failure in the accompanying table is marked with ** this means that any failure for this item will result in the issue of an immediate prohibition.

Where a Reason for Failure is marked with * the examiner will need to assess the severity of the defect in line with the Categorisation of Defects criteria (outlined in the defects column of the table in the following pages) before deciding whether to issue an immediate prohibition.

Standards for Prohibition (continued)

Manual Reference	Defect	Reason for Failure
<p>IM 6 Road Wheels and Hubs</p>	<p>More than one wheel nut/stud is missing loose or obviously not clamping or locating in the road wheel taper.</p> <p>Failure of the road wheel imminent.</p> <p>Detachment of a road wheel or hub imminent or a half shaft bolt, stud or nut missing.</p>	<p>2a*</p> <p>2g*</p> <p>3a*</p>
<p>IM8 Condition of Tyres</p>	<p>Tyre bulging caused by separation/failure of the tyre structure</p> <p>A tyre so severely damaged that failure of the tyre is likely</p> <p>Tyre tread worn below the legal minimum on tyre fitted to a steered wheel</p>	<p>1b**</p> <p>1c*</p> <p>1h*</p>
<p>IM11 Vehicle to Trailer Coupling</p>	<p>Failure of the coupling and detachment of the trailer likely</p>	<p>1c*</p> <p>1e*</p>

Standards for Prohibition (continued)

Manual Reference	Defect	Reason for Failure
<p>IM12 Trailer Parking, Emergency Brakes and Air Line Connections</p>	<p>Parking brake does not operate on at least two road wheels</p> <p>Brake mechanism fractured or defective to such an extent that the brake is inoperative or cannot be set</p> <p>Trailer brakes are not applied when the emergency brake line is disconnected</p> <p>Adapter not fitted or providing inadequate lift to the extent that the correct operation of the brake is affected</p> <p>Tap fitted preventing correct operation of the braking system</p>	<p>1a**</p> <p>1b**</p> <p>2**</p> <p>3b *</p> <p>4**</p>
<p>IM 15 Cab Security</p>	<p>Driving control likely to be affected</p>	<p>1a**</p>
<p>IM18 Seats</p>	<p>A driver's seat so insecure or in such a condition that it could cause the driver to lose control of the vehicle.</p>	<p>1*</p>
<p>IM28 Driving Controls</p>	<p>Driving control defective to the extent that it is incapable of fulfilling its function and affects the control of the vehicle</p>	<p>1e*</p>
<p>IM30 Steering Controls</p>	<p>Controls so defective that direction control of the vehicle is affected</p>	<p>1c*</p> <p>1d*</p> <p>2a*</p>
<p>IM34 Pressure/Vacuum Warning</p>	<p>Warning device fails to cease operating (indicating reservoirs not filling) – within 6 minutes for a rigid vehicle, 9 for vehicle/trailer combinations</p>	<p>3*</p>

Standards for Prohibition (continued)

Manual Reference	Defect	Reason for Failure
IM36 Hand Lever Operating Mechanical Brakes	Cannot be operated to perform its function Cannot be set or likely to disengage	1d* 1f**
IM37 Service Brake Pedal	Cannot be operated to perform its function	1c* 2b*
IM38 Service Brake Operation	Vacuum assistance is not working	3a*
IM39 Hand Operated Brake Control Valve	Valve unable to be set in the on position or moved over its original full travel	1d* 1g*
IM44 Oil Leaks	Continuous flow of oil or serious risk of fire	1*
IM45 Fuel Tanks and Systems	Detachment of tank imminent Continuous fuel leak or a leak constituting a hazard to other road users Filler cap missing or defective such as to permit gushing	1** 2b** 3a* 4a** 4b** 4c**

Standards for Prohibition (continued)

Manual Reference	Defect	Reason for Failure
<p>IM48 Suspension</p>	<p>Imminent failure of a major suspension component which would affect the control of the vehicle</p>	<p>This item covers all Reasons for Failure. Examiners will need to consider will the defect affect the control of the vehicle.</p>
<p>IM53 Axles, stub axles and wheel bearings</p>	<p>A main component so defective that failure is imminent and likely to affect the steering</p>	<p>This item covers all Reasons for Failure. Examiners will need to consider will the defect affect the control of the vehicle</p>
<p>IM54 Steering Mechanism</p>	<p>Steering mechanism so stiff or rough in operation that its operation is restricted</p> <p>Mechanism fractured or twisted to the extent that failure or detachment is imminent</p>	<p>1a* 2a* 2i* 2j* 2o*</p>
<p>IM59 Brake Systems and Components</p>	<p>Any defect likely to lead to a total failure of a braking system</p>	<p>This item covers all Reasons for Failure. Examiners will need to consider will the defect affect the control of the vehicle</p>

Standards for Prohibition (continued)

Manual Reference	Defect	Reason for Failure
IM63 Lamps	Any defect or combination of defects which make all the stop lamps inoperative	1a* – 1g* 3*
IM71 Service Brake Performance	<p>With the service brake applied:</p> <p>There is little or no brake effort at any wheel</p> <p>Braking effort from any wheel on a steered axle is less than 70% of the brake effort from another wheel on the same axle</p> <p>Efficiency significantly below legal requirements (before issuing the examiner must consider whether the vehicle, as presented, would pose an immediate danger to road safety)</p>	2d.i* 2d.ii* 2d.iii* 3*
IM72 Secondary Brake	Efficiency significantly below legal requirements (before issuing the examiner must consider whether the vehicle, as presented, would pose an immediate danger to road safety)	2b*
IM73 Parking Brake	Efficiency significantly below legal requirements (before issuing the examiner must consider whether the vehicle, as presented, would pose an immediate danger to road safety)	2b* 3b* 4b*
IM74 Other Dangerous Defects	A defect not described elsewhere in the Inspection Manual such that the use of the vehicle on the road would involve a danger of injury to any person	1**

Heavy Goods Vehicle Inspection Manual

01 Registration Plate

Application

This inspection applies to all registered motorised vehicles.

A registration plate should be easily legible to a person standing approximately 20m from the front/rear of the vehicle.

Method of Inspection	Reason for Failure
<p>1. Check that there is a registration plate at both the front and the rear of the vehicle, and check each one for:</p> <ul style="list-style-type: none">a. presence.b. security. <p>2. Check the registration mark for:</p> <ul style="list-style-type: none">a. presence.b. legibility.	<p>1. A registration plate:</p> <ul style="list-style-type: none">a. missing.b. insecure. <p>2. A registration mark:</p> <ul style="list-style-type: none">a. missing.b. illegible.

03 Seat Belts & Supplementary Restraint Systems

Application

This inspection applies to all vehicles with seat belts and/or Supplementary restraint systems (SRS) fitted.

The minimum requirement for the fitment of seat belts is detailed in the tables below.

The only goods vehicles up to and including 3500kg DGW likely to be subject to this inspection are mini-articulated vehicles.

Minimum Requirements for Forward Facing Seats on Vehicles First Used from 1 October 2001 with A DGW in Excess of 3500kg

Driver's seat	Front passenger seats	Rear passenger seats
3 point belt (lap and diagonal) or lap belt	3 point belt (lap and diagonal), lap belt or disabled person's belt	No belt required

Vehicles First Used from 1 April 1980 up to and Including 3500kg DGW

Vehicle first used:	Driver's and specified front passenger seat (furthest from driver)	Other front passengers	Rear passengers
1/4/1980 to 31/3/1981	2 point belt (diagonal body restraining)	No belt required	No belt required
1/4/1981 to 31/3/1987	3 point belt (lap and diagonal)	No belt required	No belt required
From 1/04/1987	3 point belt (lap and diagonal)	3 point belt (lap and diagonal), lap belt or disabled person's belt	No belt required

03 Seat Belts & Supplementary Restraint Systems

Application

Seat belts are not required on light goods vehicles with an ULW exceeding 1525kg, if the model of vehicle was first manufactured before 1 October 1979 and the vehicle was manufactured before 1 October 1981, or first used before 1 April 1982.

For seats with integral seat belts, it may not be possible to examine the fixing of the seat belt to the seat.

On retracting seat belts, check that with the mechanism fastened and the seat adjusted to its rearmost position, excess webbing is wound into the retracting unit. If there is doubt about the operation of the retracting unit, this check should be carried out with the seat unoccupied.

Some types of retracting belt might need manual help before they retract.

Operate the release mechanism while pulling on the belt to check that the mechanism releases when required.

Pull the sheaths aside if this can be done without damage

Some vehicles have seat belts which will not release the inertia aspect of the seat belt unless the ignition is switched on. Ensure the park brake is applied and the gears are in the neutral position before switching on the ignition. Owing to the height of cabs on many commercial vehicles this inspection should be performed with the inspector sat in the appropriate seat.

Floor mounted anchorages may need to be inspected from underneath the vehicle.

Where a belt is fitted with no corresponding seat or if there is a buckle/stalk but no corresponding belt, it is NOT to be considered a seat belt for the purpose of this inspection.

The inspection of Supplementary Restraint Systems (SRS) applies to airbags, seat belt pre-tensioners and seat belt load limiters when fitted as standard.

03 Seat Belts & Supplementary Restraint Systems

Application

The SRS malfunction indicator lamp (MIL) may display a symbol similar to that below, one depicting a person wearing a seat belt. or alternatively the letters 'SRS'.



A passenger air bag which has been switched off is not a reason for failure.

Seat belt load limiters are used on some vehicles to minimise seat belt inflicted injury in particularly violent collisions.

This is generally achieved by releasing a little more excess belt webbing when a great deal of force is applied to the belt.

The simplest type of load limiter is a fold sewn into the belt webbing. The stitches holding the fold in place are designed to come apart when a high amount of force is applied to the belt, thereby releasing an extra bit of webbing.

More advanced load limiters rely on a torsion bar in the retractor mechanism, which cannot usually be readily seen or tested.

Seat belt pre-tensioners may be fitted to some seat belts. Once activated a warning device may display.

Method of Inspection	Reason for Failure
<p>1. Check Obligatory Seat Belts:</p> <ul style="list-style-type: none"> a. for presence. b. are of the correct type. <p>Check the condition of all seat belts fitted.</p> <p>2. Anchorages:</p> <ul style="list-style-type: none"> a. without dismantling check there is no excessive corrosion, serious deterioration or a fracture within 300mm (12") of the anchorage (where a seat belt is attached to a seat frame this will apply to all seat mounting points). b. check seat belt/s are securely fixed to the seat or to the vehicle structure. 	<p>1. Obligatory Seat Belt (see Table):</p> <ul style="list-style-type: none"> a missing. b of an incorrect type. <p>2. Anchorages:</p> <ul style="list-style-type: none"> a. with excessive corrosion, serious deterioration or a fracture in a load bearing member of the vehicle structure within 300mm (12") of the anchorage (where a seat belt is attached to a seat frame this will apply to all seat mounting points). b. a seat belt not securely fixed to the seat or to the vehicle structure.

03 Seat Belts & Supplementary Restraint Systems

Method of Inspection	Reason for Failure
<p>3. Check Locking Mechanism, Stalks, Retracting Mechanism and Fittings. Fasten each belt locking mechanism and try and pull the locked sections apart:</p> <p>a. check the locking mechanism of the seat belt/s secure and release as intended.</p> <p>b. check the attachment and adjustment fitting for fractures, deterioration and that it is operating effectively.</p> <p>c. check the flexible stalk is free from corrosion or deterioration likely to lead to failure under load.</p> <p>d. check there are no broken flexible stalk strands.</p> <p>e. check the retracting mechanism retracts the webbing sufficiently to remove all the slack from the belt with the locking mechanism fastened.</p> <p>4. Check that the Webbing:</p> <p>a. has no cut which causes the fibres to separate.</p> <p>b. has no fluffing or fraying sufficient to obstruct correct operation of the belt or which has clearly weakened the webbing.</p> <p>c. has no stitching badly frayed, is secure, complete and has not been repaired.</p>	<p>3. Locking Mechanism, Stalks, Retracting Mechanism and Fittings:</p> <p>a. locking mechanism of a seat belt does not secure or release as intended.</p> <p>b. an attachment or adjustment fitting fractured, badly deteriorated or not operating effectively.</p> <p>c. corrosion or deterioration of a flexible stalk likely to lead to failure under load.</p> <p>d. broken flexible stalk strands.</p> <p>e. a retracting mechanism does not retract the webbing sufficiently to remove all the slack from the belt with the locking mechanism fastened.</p> <p>4. Condition of Webbing:</p> <p>a. a cut which causes the fibres to separate.</p> <p>b. fluffing or fraying sufficient to obstruct correct operation of the belt or which has clearly weakened the webbing.</p> <p>c. stitching badly frayed, insecure, incomplete or repaired.</p>

03 Seat Belts & Supplementary Restraint Systems

Method of Inspection	Reason for Failure
<p>5. Check for obvious signs of structural weakness such that failure is likely in, seat belt; fittings, guides, stalks or pivots.</p> <p>6. Check seats with seat belts attached to them for:</p> <ul style="list-style-type: none"> a. security. b. there are no cracks or fractures in the leg or frame. <p>7. Check the presence and condition of any seat belt load limiters and/or pretensioners fitted as original equipment.</p> <p>8. As far as practicable, check that:</p> <ul style="list-style-type: none"> a. all driver and passenger airbags fitted as original equipment, are present and b. are not obviously defective. <p>9. Check the SRS warning light does not indicate a fault.</p>	<p>5. Obvious signs of structural weakness in a Seat belt; fitting, guide,stalk or pivot such that failure is likely.</p> <p>6. Seats with seat belts attached to them:</p> <ul style="list-style-type: none"> a. insecure. b. with a cracked or fractured leg or frame. <p>7. A seat belt:</p> <ul style="list-style-type: none"> a. load limiter or pretensioner obviously missing where fitted as original equipment. b. pretensioner or a 'folded type' webbing load limiter obviously deployed. <p>8. An airbag:</p> <ul style="list-style-type: none"> a. missing. b. obviously defective. <p>9. The SRS warning lamp indicates any kind of failure in the system.</p>

Heavy Goods Vehicle Inspection Manual

05 Exhaust Emissions

Application

This inspection applies to all Diesel and other Compression Ignition engine vehicles. For Hybrid Electric Vehicles see below ninth bullet point.

Diesel and other Compression Ignition Engines:

- **Exhaust emissions must be tested** using an approved and calibrated smoke meter.
- **Only in exceptional circumstances** where it is not possible to use a smoke meter will a visual check be carried out. Visual tests will not apply to Fast Pass or vehicles submitted for **Reduced Pollution Certification**.
- **If the exhaust has been deliberately modified** to prevent the smoke meter from being used a VTG 12 must be issued refusing to complete the test because the exhaust smoke emissions test cannot be carried out.
- **Twin exhaust systems, without a balance pipe** - both systems must be individually tested for smoke emissions. It may be necessary to purge the exhaust system again prior to the second check.
- **Supercharged engines** should be tested by selecting the non-turbocharged option on the smoke meter.
- **The test procedure** for turbocharged and non-turbocharged engines is the same.
- **It is not normally sufficient** to run the engine with the vehicle stationary to warm it up to temperature, so the emissions should be tested as soon as possible after the vehicle arrives at the test station.
- **With some types of smoke meter** care must be taken to ensure that the probe is correctly aligned to the exhaust gas flow (reference to meter manufacturer's instruction may be necessary).
- HEVs do not require a metered smoke test or a visual smoke test as described in MOI 2. However where there is a supplementary engine used, this should be observed that it does not emit excessive smoke. If excessive smoke is observed this is a RfF under item 2b.

Heavy Goods Vehicle Inspection Manual

05 Exhaust Emissions

Application

Some diesel smoke meters (DSM) may fail to trigger a reading when testing modern vehicles fitted with low emission diesel engines which produce very low levels of smoke. If the smoke meter does not register a reading or shows an error reading follow step one or two below as appropriate:

1. If the DSM produces a print out, this should be marked showing that the emissions limits were tested and met but the DSM could not register the reading. This should be attached to the test card in the normal way.
2. If the DSM will not produce a printout, the tester should make a note on the bottom of the **test card** stating that the emissions limits were tested and met but the DSM could not register the reading.

Air Fuel Ratio Control (AFRC) fitted to Caterpillar engines. When the engine is stopped the control goes into an excess fuel position. When the engine is restarted the inlet manifold pressure necessary to reset the AFRC into its normal running position is normally greater than that generated during the free acceleration test. Vehicles should therefore either be checked at the start of the test if the engine has not been stopped or at the end of the test where the vehicle should be driven on the test track against the load of a partially applied brake sufficient to reset the AFRC prior to conducting the test.

If a vehicle fails the test because the exhaust is holed the emissions must be rechecked when the vehicle is retested.

Remember to issue a printout.

Heavy Goods Vehicle Inspection Manual

05 Exhaust Emissions	
Method of Inspection	Reason for Failure
<p>1. Free acceleration test using smoke meter</p> <p>1a.</p> <ul style="list-style-type: none"> i. Check that the engine is at or near normal operating temperature. ii. Purge the inlet and exhaust systems fully by holding the engine speed steady at just below maximum governed speed for 30 seconds. iii. Select the appropriate test programme on the smoke meter. iv. Follow the meter prompts; depress the accelerator pedal quickly but not violently, to reach full fuel position in less than 1 second. Hold it there until a release prompt is given. If, at the end of the 1st acceleration, the smoke meter value is no more than 1.50m⁻¹ the vehicle will have met the fast pass limit. v. If the 1st meter reading is more than 1.50m⁻¹ further accelerations will be required, following meter prompts, up to a maximum of 6 accelerations. vi. For vehicles first registered from 1 July 2008. If they fail the fast pass test you will need to choose the most appropriate programme for the meter to perform a full metered smoke test, should the meter only allow 3 accelerations you may need to repeat the exercise to gain the 6 accelerations required and then look for 3 consecutive results from both printouts before deciding whether the vehicle should pass or fail (It is recommended that RPC4 is chosen for this operation). <p>1b. Assess visually whether the smoke emitted from the exhaust regardless of the measured density, is likely to obscure the vision of other road users.</p>	<p>1. Statutory Smoke Meter Test</p> <p>1a.</p> <p>After a total of six accelerations have been completed, the average smoke opacity recorded for accelerations 4, 5 and 6 is more than:</p> <p>For vehicles registered prior to 1 July 2008:</p> <ul style="list-style-type: none"> • 2.5m⁻¹ for non-turbocharged engines • 3.0m⁻¹ for turbocharged engines. <p>For vehicles first registered from 1 July 2008:</p> <ul style="list-style-type: none"> • 1.5m⁻¹ for all diesel engines. <p>1b. The exhaust emits excessive smoke or vapour of any colour, to an extent likely to obscure vision.</p>

Heavy Goods Vehicle Inspection Manual

05 Exhaust Emissions	
Method of Inspection	Reason for Failure
<p>2. Visual emission test</p> <p>2a.</p> <ul style="list-style-type: none"> i. Only in exceptional circumstances where it is not possible to use a smoke meter will a visual check be carried out. The visual test is only to be used when it is not possible to use the smoke meter or where risk to health and safety would arise. The procedure is the same for supercharged, turbocharged and non-turbocharged engines. ii. With the engine at or near normal operating temperature check the density of the exhaust emission visually. iii. Ask the driver to depress the accelerator pedal quickly but not violently, to reach full fuel position in less than 1 second. Immediately release when the engine reaches its maximum governed speed, allow the engine to return to idle speed. iv. Ignore smoke from the first acceleration. v. Repeat up to a maximum of six times if necessary until the exhaust smoke is considered to be acceptable for two successive accelerations. <p>2b. Assess whether the smoke emitted from the exhaust, regardless of the measured density, is likely to obscure the vision of other road users.</p> <p>3. Check the vehicle for presence of emission control systems fitted as standard.</p>	<p>2. Statutory visual test</p> <p>2a.</p> <p style="padding-left: 20px;">After a maximum of six accelerations the exhaust emits smoke of a level greater than that of equivalent metered levels.</p> <p>2b. The exhaust emits excessive smoke or vapour, of any colour, to an extent likely to obscure vision.</p> <p>Note: The criterion is density and not volume of smoke. The description `dense smoke` includes any smoke or vapour which largely obscures vision.</p> <p>3. A Catalytic converter, particulate filter or selective catalytic reduction system missing where it was fitted as standard.</p>

Heavy Goods Vehicle Inspection Manual

05 Exhaust Emissions

Method of Inspection

Reduced Pollution Certificate (RPC) Smoke meter test

The RPC check is **not** part of the statutory test requirement.

1. Select appropriate RPC limit. Carry out Method of Inspections listed at 1.a procedures I, II and III only.
2. Following meter prompts carry out three acceleration tests. Depress the accelerator pedal quickly but not violently, to reach full fuel position **in less than 1 second**. Hold it there until a release prompt is given. At the end of the 3rd acceleration the smoke meter will display the average smoke value and test result. If the RPC value is not met and the meter readings are above the statutory limits, further accelerations up to a maximum of six may be prompted by the meter.

A vehicle will pass the RPC metered test if the opacity level is no greater than:

- 0.2m⁻¹ for all vehicles fitted with a particulate trap.
- 0.4m⁻¹ vehicles fitted with an unmodified Euro -2 engine.
- 0.8m⁻¹ vehicles fitted with an unmodified Euro -1 engine.
- 1.0m⁻¹ vehicles retro-fitted with a Euro -2 engine.

Heavy Goods Vehicle Inspection Manual

06 Road Wheels and Hubs

Application

This inspection applies to all road wheels and hubs apart from spare wheels.

Where possible wheel nuts will be lightly tapped with a hammer to check for looseness, but any other evidence such as rust marks or elongation of bolt/stud holes must also be taken into account.

A nut or stud is considered to be “loose” if it is not obviously carrying out its function of clamping the wheel to the hub.

With some vehicles it is not possible to see the road wheels completely from ground level, especially with twin wheels and where the body hides part of the wheels. In such cases the vehicle must be moved to expose hidden parts of the wheels, or examined from underneath.

Whenever possible, presenters should remove wheel embellishers; remove visual security indicators, if they prevent a full examination. Where this can not be accomplished, continue to inspect the vehicle and annotate the test card to state that the embellishers were not removed.

Capacity Limitations of 11.75 x 22.5 Alcoa Aluminium Wheels.

Wheels with the part number 813520/813523 may be stamped on the inside of the wheel, opposite the valve, with a maximum load rating of 4250kg or 4500kg and those with part number 813530/813533 with a rating of 4500kg. It has been agreed that wheels with these part numbers and maximum load ratings are suitable for a maximum axle weight of 9150kg.

Kronprinz wheels fitted to the Volvo FL L 4x2 rigid and FL 6H 4x2 rigid, are capable of carrying higher loads than those shown on the wheels. The wheels can be identified by the following markings stamped on the wheel:

Wheel brand name	Kronprinz
Clamping type	M20
Place of manufacture	Made in France
Designation	19.5 x 7.50HOS56 E-DOT
Wheel load index	144/142
Volvo part number	20946506

The wheel is capable of carrying a load equatable to a 145/143. Please be aware of the increased load capacity should you observe these wheels at annual test. This weight increase is applicable to all vehicles equipped with these wheels not just Volvo.

06 Road Wheels and Hubs

Application

Capacity limitation of a wheel marked with a load index

If a wheel is marked with a load index which indicates that the maximum load is lower than is required to support the axle load, the vehicle should be failed under Reason for Failure 2.i.

Wheels not marked with a load index or load marking must be assumed to be capable of carrying the axle weight.

Compatibility of Wheel Fixings

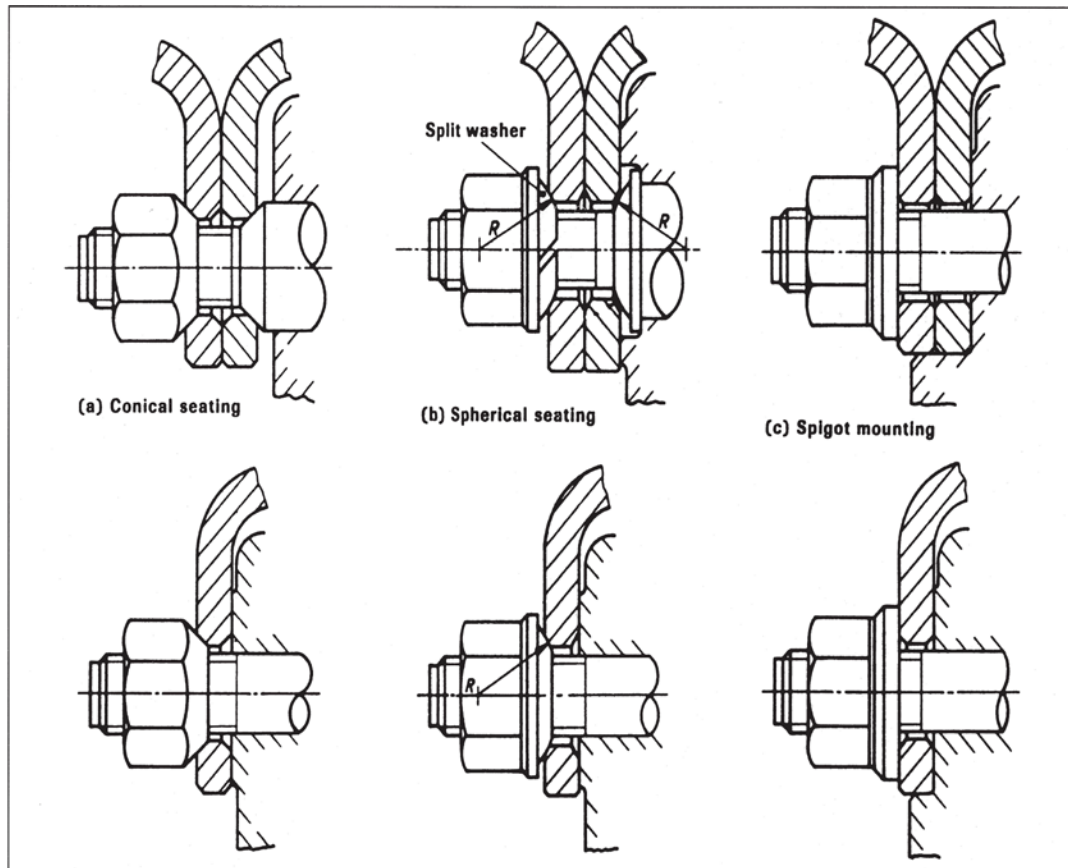

Vehicles with conical wheel fixings **MUST NOT** be fitted with wheels from vehicles designed for use with spherical fixings. (British built vehicles normally have conical wheel fixings).

Vehicles with spherical wheel fixings **MUST NOT** be fitted with wheels from vehicles which are designed for use with conical fixings.

Volvo wheels of the original spigot-mounting design **WILL NOT** interchange with another type. Volvo wheels designed for later type spigot mounting may be used in an emergency on British built trailers.

Wheels with conical fixings **MUST NOT** be used on Volvo vehicles because they do not have a machine centre bore to fit hub

06 Road Wheels and Hubs
Application

Sleeved two piece flange nut fixing

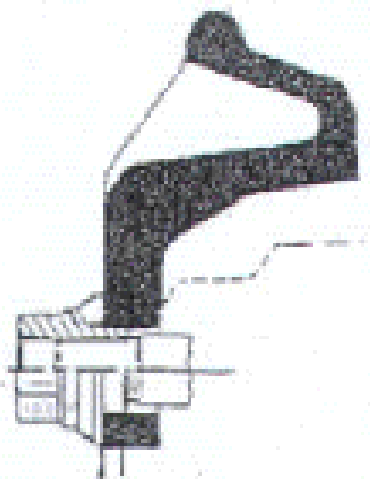

Single wheel location

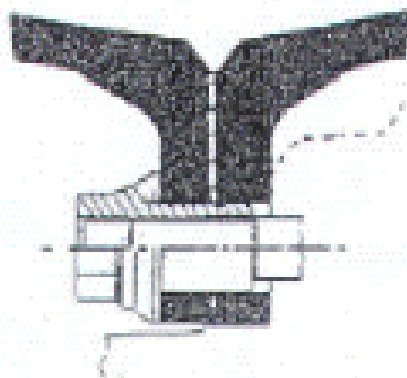

Twin Wheel Spigot Mounting

Sleeved two piece flange nut fixing, this fixing method of utilising a sleeved nut has been adopted primarily to allow the retro fitting of aluminium wheels which incorporate a thicker flange.

Where wheel trim brackets are secured by the wheel retaining nuts it is acceptable provided the bracket does not stop the wheel nut from seating correctly in the taper of the stud hole. For spigot mounted wheels there may be some overlap between the washer and bracket, failure will only be justified where the nut clamping force is obviously ineffective.

Some wheel nut studs do not protrude all the way through the wheel nut this is acceptable provided there is no sign of insecurity.

Where twin wheels are fitted the spigots must extend to the outer wheel to locate this.

Heavy Goods Vehicle Inspection Manual

06 Road Wheels and Hubs

Method of Inspection	Reason for Failure
<p>1. Check tyre retaining rings for:</p> <ul style="list-style-type: none"> a. fractures. b. clearance, (butting of the ends is acceptable with lift on the flange up to 1.5mm from the rim). <p>2. Check all road wheels for:</p> <ul style="list-style-type: none"> a. presence, security and function of all retaining nuts and studs. b. elongation of a stud hole. c. the condition of spigot wheel nut washers. d. damage or distortion and the presence of the locating spigot or dowel. e. damage caused by wheel nuts f. compatible fixings. g. condition, cracks (except at the bridge over the valve), welds and repairs. h. repairs by welding to aluminium alloy wheels. i. the correct load rating that is required to support the maximum permissible (GB) axle load. <p>3. Check hubs for:</p> <ul style="list-style-type: none"> a. condition, and that the half shaft bolts, studs or nuts are secure. b. clearance between a spigot mounted wheel and the hub spigots. 	<p>1. A tyre retaining ring:</p> <ul style="list-style-type: none"> a. fractured. b. butting causing the flange to lift more than 1.5mm from the rim. <p>2. A wheel:</p> <ul style="list-style-type: none"> *a. nut or stud missing or loose or obviously not fulfilling the function of clamping the wheel to the hub. b. with any visible elongation of a stud hole. c. with a spigot wheel nut washer cracked. d. badly damaged or distorted or with a locating spigot or dowel missing. e. damaged by the corners of a wheel nut cutting into the material of the wheel. f. and its fixings not compatible. *g. cracked (except at the bridge over the valve), weld breaking away or an inadequate repair. h. made of aluminium alloy repaired by welding. i. with a load rating less than that required to support the maximum permissible (GB) axle load. <p>3. A hub:</p> <ul style="list-style-type: none"> *a. cracked, badly damaged, or with a half shaft bolt, stud or nut loose or missing. b. with clearance between a spigot mounted wheel and the hub spigots that exceeds 3mm across the diameter.

07 Size and Type of Tyres

Application

This inspection applies to all tyres, apart from spare tyres.

The use markings most likely to be encountered are "FRT" which indicates that the tyre is not suitable for use on a driven axle and "TRAILER USE ONLY". Tyres marked with a direction arrow pointing in the wrong direction should not be failed.

Tyres are usually identified by their nominal section size followed by the rim diameter e.g. 10.00-20,750-16, etc (the majority of modern tyres carry millimetric markings e.g. 205-16 etc). For identification of sidewall markings refer to the diagram at the end of this section. All tyres on an axle must be of the same nominal size. If a tyre is dual marked one of the markings must be the same as the markings on the other tyres on the axle.

There are still a number of high load capacity tyres in use which are marked with a code to indicate the tyre size and capacity e.g. a 10.00-20 16 ply tyre may be marked D20 or 4-20 (a full list of these tyres is given at Table 1).

If tyres marked with a load capacity index are fitted the maximum permissible axle Load for normal use can be found in Table 2 at the end of this section. The Load Index (LI) may consist of one or two numbers e.g. 154 or 146/143. Where two numbers are displayed the first refers to the use of the tyre in single formation and the second in twin formation. Reference to the table shows that the maximum loads for this tyre are 6000kg in single formation and 10900 in twin formation.

If a load index is not shown the carrying capacity of a tyre can be determined from the Ply Rating. The load capacity of ply rated tyres is shown at Table 3. If no ply rating can be found on the tyre it should be assumed to have the lowest load capacity listed for that size of tyre.

This information relates to tyres used without any restriction (i.e. with tyre use symbol 2B indicated on the plate or plating certificate). There are three other categories of vehicle use which allow tyres to be operated at lower speeds and higher loads. The details of the axle loads are in the Tyre Tables obtainable from the Driver and Vehicle Standards Agency, Ellipse, Padley Road, Swansea SA1 8AN.

07 Size and Type of Tyres

Application

2J SPEED RESTRICTED TO 40MPH

This category is applicable to “Municipal vehicles”. “Municipal vehicles” means a motor vehicle or trailer limited at all times to use by a local authority, or a person acting in pursuance of a contract with a local authority, for road cleansing, road watering or the collection and disposal of refuse, night soil or the contents of cesspools, or the purposes of the enactments relating to weights and measures or the sale of food and drugs:

OR “Multi-stop local collection and delivery vehicles” being a motor vehicle or trailer used for multi-stop collection and delivery services to be used only within a radius of 25 miles from the permanent base at which it is normally kept.

2M SPEED RESTRICTED TO 40MPH

This category is applicable to a “low platform trailer” being a trailer fitted with tyres with a rim diameter size code of less than 20 and displaying a rectangular plate which is at least 225mm wide and at least 175mm high and bears two black letters “L” at least 125mm high and 90mm wide with a stroke width of 12mm.

2R SPEED RESTRICTED TO 50MPH

This category is applicable to any vehicle which displays a “50” plate in accordance with Schedule 13 of the C & U regulations.

SPEED SYMBOLS

The speed capability is represented by a letter which is displayed adjacent to the LI marking e.g. 146/143J. This indicates the speed at which the tyre can carry the load(s) indicated by the LI marking(s). In the above example the tyres carry a load of 6000/10900kg at 62mph.

The minimum required speed ratings are :

CLASS OF VEHICLE	PERMITTED SPEED (MPH)	MINIMUM SPEED SYMBOL
Rigid goods vehicles with maximum laden weight not exceeding 7.5 tonnes	70	L
Rigid goods vehicles with maximum laden weight exceeding 7.5 tonnes	60	J
Articulated vehicles	60	J
Trailers	60	J
Goods vehicles and trailers operating under 2J or 2M tyre use conditions	40	D
Restricted speed vehicles operating under 2R tyre use conditions	50	F

07 Size and Type of Tyres

Application

ALTERNATIVE SPEED RATINGS

Certain vehicles can be fitted with tyres showing a lower speed rating than those shown above but the maximum axle loads will be reduced as shown below.

CLASS OF VEHICLE	NORMAL SPEED RATING	ALTERNATIVE SPEED RATING	REDUCTION IN AXLE LOADS
Motor vehicle not exceeding 7500kg plated weight	L	J	7%
		K	3%
Trailers	J	F	15%
		G	5%

Details of the reduced axle loads which tyres can carry are shown in Table 4.

STRUCTURE

Examine all the tyres fitted and note the type of structure (radial, cross-ply or bias-belted) and the nominal size of tyres.

All tyres on an axle must be of the same structure and nominal size.

Tyres on an axle may be of different structures and nominal sizes to those on another axle with the following exceptions:

- All tyres on all steered axles must have the same structure.
- All tyres on all driven axles must have the same structure.
- On two axle motor vehicles where each axle is fitted with single wheels, if all the tyres are not of the same structure, the type of structure which is allowed to be fitted to each axle is shown in the table.

Axle 1	Axle 2
Cross-ply	Bias-belted
Cross-ply	Radial
Bias-belted	Radial

This does not apply to an axle on which wide single tyres with a road contact width of more than 300mm are fitted.

Heavy Goods Vehicle Inspection Manual

07 Size and Type of Tyres

Application

TABLE 1

CODE	TYRE SIZE
A16 or 1 — 16	750 — 16 — 12 PR
B16 or 2 — 16	825 — 16 — 14PR
C16 or 3 — 16	900 — 16 — 14 PR
B17 or 2 — 17	825 — 17 — 14 PR
A20 or 1 — 20	750 — 20 — 12 PR
B20 or 2 — 20	825 — 20 — 14 PR
C20 or 3 — 20	900 — 20 — 14 PR
D20 or 4 — 20	1000 — 20 — 16 PR
E20 or 5 — 20	1100 — 20 — 16 PR
F20	1200 — 20 — 18 PR
G20	1400 — 20 — 22 PR
E22 or 5 — 22	1100 — 22 — 16 PR
B22.5 or 2 — 22.5	9 — 22.5 — 14 PR
C22.5 or 3 — 22.5	10 — 22.5 — 14 PR
D22.5 or 4 — 22.5	11 — 22.5 — 16 PR
E22.5	12 — 22.5 — 16 PR
C24 or 3 — 24	900 — 24 — 14 PR
E24	1100 — 24 — 16 PR

Heavy Goods Vehicle Inspection Manual

07 Size and Type of Tyres

Application

Table 2 Load capacity index table

Extract from ECE Reg 54: "Load index" Table amended to show axle loads

Load Index	Single Kg	Dual Kg	Load Index	Single Kg	Dual Kg	Load Index	Single Kg	Dual Kg
70	670	1340	100	1600	3200	130	3800	7600
71	690	1380	101	1650	3300	131	3900	7800
72	710	1420	102	1700	3400	132	4000	8000
73	730	1460	103	1750	3500	133	4120	8240
74	750	1500	104	1800	3600	134	4240	8480
75	774	1548	105	1850	3700	135	4360	8720
76	800	1600	106	1900	3800	136	4480	8960
77	824	1648	107	1950	3900	137	4600	9200
78	850	1700	108	2000	4000	138	4720	9440
79	874	1748	109	2060	4120	139	4860	9720
80	900	1800	110	2120	4240	140	5000	10000
81	924	1848	111	2180	4360	141	5150	10300
82	950	1900	112	2240	4480	142	5300	10600
83	974	1948	113	2300	4600	143	5450	10900
84	1000	2000	114	2360	4720	144	5600	11200
85	1030	2060	115	2430	4860	145	5800	11600
86	1060	2120	116	2500	5000	146	6000	12000
87	1090	2180	117	2570	5140	147	6150	12300
88	1120	2240	118	2640	5280	148	6300	12600
89	1160	2320	119	2720	5440	149	6500	13000
90	1200	2400	120	2800	5600	150	6700	13400
91	1230	2460	121	2900	5800	151	6900	13800
92	1260	2520	122	3000	6000	152	7100	14200
93	1300	2600	123	3100	6200	153	7300	14600
94	1340	2680	124	3200	6400	154	7500	15000
95	1380	2760	125	3300	6600	155	7750	15500
96	1420	2840	126	3400	6800	156	8000	16000
97	1460	2920	127	3500	7000	157	8250	16500
98	1500	3000	128	3600	7200	158	8500	17000
99	1550	3100	129	3700	7400	159	8750	17500

Heavy Goods Vehicle Inspection Manual

07 Size and Type of Tyres

Application

Table 2 Continued Load capacity index table

Extract from ECE Reg 54: "Load index" Table amended to show axle loads

Load Index	Single Kg	Dual Kg	Load Index	Single Kg	Dual Kg	Load Index	Single Kg	Dual Kg
160	9000	18000						
161	9250	18500						
162	9500	19000						
163	9750	19500						
164	10000	20000						
165	10300	20600						
166	10600	21200						
167	10900	21800						
168	11200	22400						
169	11600	23200						
170	12000	24000						
171	12300	24600						
172	12600	25200						
173	13000	26000						
174	13400	26800						
175	13800	27600						
176	14200	28400						
177	14600	29200						
178	15000	30000						
179	15500	31000						

**07 Size and Type of Tyres
Application**

1. Ply Rating Marked Tyres

How to use this table:

1. Locate the line entry corresponding to the size and ply rating marked on the tyre sidewall;
2. Read off the maximum axle load (kg) for these tyres in 'SINGLE' or 'TWIN' formation, as appropriate.

TABLE 3

Nominal Tyre Size	Ply Rating	Maximum Axle Load (Kg)	
		Single Tyres	Twin Tyres
145 - 13C	6	970	1840
145 - 13C	8	1120	2120
560 - 13C	6	1020	1940
590 - 13C	6	1070	2090
640 - 13C	6	1280	2240
640 - 13C	8	1430	2750
670 - 13C	6	1380	2650
670 - 13C	8	1580	3050
1050 - 13	12	4320	7880
1050 - 13	14	4830	8900
155 - 14C	6	1070	2040
165 - 14C	6	1300	2460
165 - 14C	8	1460	2760
175 - 14C	6	1430	2680
175 - 14C	8	1550	3000
185 - 14	RADIAL	1200	2300
185 - 14	REINFORCED RAD	1340	2560
185 - 14	4	1340	2560
185 - 14C	6	1550	2920
185 - 14C	8	1700	3200
195 - 14	RADIAL	1300	2490
195 - 14	REINFORCED RAD	1500	2870
195 - 14C	6	1700	3210
195 - 14C	8	1900	3600
205 - 14	RADIAL	1420	2720
205 - 14	REINFORCED RAD	1650	3160
205 - 14C	6	1850	3510
205 - 14C	8	2060	3900
215 - 14C	8	2240	4240
590 - 14C	6	1170	2240
600 - 14C	8	1260	2400

Nominal Tyre Size	Ply Rating	Maximum Axle Load (Kg)	
		Single Tyres	Twin Tyres
640 - 14C	6	1330	2550
650 - 14	4	970	1860
650 - 14C	6	1300	2460
650 - 14C	8	1500	2840
670 - 14C	6	1430	2750
670 - 14C	8	1680	3160
700 - 14	4	1070	2050
700 - 14C	6	1380	2650
750 - 14	4	1200	2300
750 - 14C	6	1530	2950
750 - 14C	8	1730	3360
11-15	6	2240	—
145 - 15C	8	1230	2320
185 - 15C	8	1750	3400
590 - 15C	6	1220	2340
640 - 15C	6	1380	2650
670 - 15C	6	1530	2900
670 - 15C	8	1780	3460
670 - 15	10	2000	3900
700 - 15C	6	1750	3400
700 - 15C	8	1940	3760
700 - 15	12	2440	4580
750 - 15C	6	1830	3560
750 - 15C	8	2060	3970
750 - 15	10	2340	4370
750 - 15	12	2750	5340
750 - 15	14	3150	6100
750 - 15	16	3660	6860
825 - 15	12	3050	5590
825 - 15	14	3360	6360
825 - 15	18	4680	8540
825 - 15	20	5000	9440
1000 - 15	12	3870	7120
1000 - 15	14	4320	8130
1000 - 15	16	5020	9580
1000 - 15	18	5400	10170

Nominal Tyre Size	Ply Rating	Maximum Axle Load (Kg)	
		Single Tyres	Twin Tyres
175 - 16C	6	1500	2840
175 - 16C	8	1650	3100
185 - 16C	8	1800	3400
195 - 16C	8	1950	3700
205 - 16C	6	1900	3610
205 - 16C	8	2120	4000
215 - 16C	6	2120	4000
215 - 16C	8	2300	4360
235 - 85 - 16	10	2760	5040
600 - 16	6	1380	2550
600 - 16	8	1530	2920
600 - 16	10	1830	3300
650 - 16	6	1530	2920
650 - 16	8	1830	3460
650 - 16	10	2040	3900
700 - 16	6	1730	3260
700 - 16	8	2040	3870
700 - 16	10	2340	4480
700 - 16	12	2650	5000
750 - 16	6	2040	3870
750 - 16	8	2240	4270
750 - 16	10	2500	4720
750 - 16	12	2900	5600
825 - 16	8	2650	4880
825 - 16	10	2850	5440
825 - 16	12	3300	6400
825 - 16	14	3600	6800
900 - 16	6	2360	4360
900 - 16	8	2720	5140
900 - 16	10	3050	5600
900 - 16	12	4070	7200
900 - 16	14	4320	7800
1050 - 15	12	4580	8130

Heavy Goods Vehicle Inspection Manual

07 Size and Type of Tyres

Application

TABLE 3 (continued)

Nominal Tyre Size	Ply Rating	Maximum Axle Load (Kg)	
		Single Tyres	Twin Tyres
1400 - 16	18	7880	—
1400 - 16	20	8390	—
1400 - 16	22	9150	—
9.50 - 16.5	6	2130	3750
825 - 17	10	3260	5850
825 - 17	12	3560	6200
825 - 17	14	3820	7200
8 - 17.5C	8	2300	4480
8 - 17.5	10	2570	5000
8.5 - 17.5	RADIAL	2900	5600
9.5 - 17.5	RADIAL	3400	6400
8 - 19.5	RADIAL	3100	6000
9 - 19.5	RADIAL	3800	7200
9.5 - 19.5	RADIAL	4240	7800
600 - 20	6	1430	2750
600 - 20	8	1630	3100
600 - 20	10	1830	3460
650 - 20	6	1830	3460
650 - 20	8	2240	4070
650 - 20	10	2440	4680
700 - 20	8	2240	4480
700 - 20	10	2650	4880
700 - 20	12	2850	5340
750 - 20	8	2850	5340
750 - 20	10	3260	6000
750 - 20	12	3600	7000
825 - 20	10	3560	6610
825 - 20	12	3820	7200
825 - 20	14	4120	7800
900 - 20	10	4070	7630
900 - 20	12	4580	8240
900 - 20	14	5000	9200

Nominal Tyre Size	Ply Rating	Maximum Axle Load (Kg)	
		Single Tyres	Twin Tyres
1000 - 20	12	4830	8640
1000 - 20	14	5340	9720
1000 - 20	16	6100	10900
10.5 - 20	6	2800	—
1100 - 20	12	5340	9660
1100 - 20	14	6100	10900
1100 - 20	16	6610	11600
1200 - 20	14	6100	10600
1200 - 20	16	6860	12000
1200 - 20	18	7630	13010
12.5 - 20	10	3700	—
1300 - 20	16	7800	—
1300 - 20	18	8900	—
1300 - 20	20	*9300	—
1400 - 20	18	9150	—
1400 - 20	20	*9510	—
1400 - 20	22	*10000	—
14.5 - 20	10	4000	—
1500 - 20	20	10600	—
1500 - 20	22	11600	—
1500 - 20	24	12600	—
1600 - 20	14	6100	—
1600 - 20	20	11400	—
1600 - 20	22	12500	—
1600 - 20	24	13600	—
13/80 - 20	18	7300	13000
14/80 - 20	18	8250	—
1100 - 22	12	5590	10170
1100 - 22	14	6100	10810
1100 - 22	16	6860	12000

Nominal Tyre Size	Ply Rating	Maximum Axle Load (Kg)	
		Single Tyres	Twin Tyres
9 - 22.5	10	3560	6610
9 - 22.5	12	3820	7200
9 - 22.5	14	4120	7800
10 - 22.5	10	4070	7630
10 - 22.5	12	4580	8240
10 - 22.5	14	5000	9200
11 - 22.5	12	4830	8640
11 - 22.5	14	5340	9720
11 - 22.5	16	6100	10900
13 - 22.5	18	7500	13000
10/70 - 22.5	14	5000	9200
11/70 - 22.5	12	5300	9720
11/70 - 22.5	14	5600	10300
11/70 - 22.5	16	6100	10900
12/70 - 22.5	16	6610	11600
13/70 - 22.5	18	7630	13010
275/20 - 22.5	RADIAL	5000	9200
275/70 - 22.5	16	6100	—
315/70 - 22.5	16	6610	11600
900 - 24	12	5090	9150
900 - 24	14	5340	10170
1000 - 24	14	6100	10500
1100 - 24	12	5850	10300
1100 - 24	14	6610	11200
1100 - 24	16	7120	12300
1200 - 24	14	6610	—
1200 - 24	16	7370	—
1200 - 24	18	8130	—
1200 - 24	20	9000	—
1400 - 24	18	10000	—
1400 - 24	22	11200	—
11 - 24.5	14	5830	10800

Note: Items marked '**' are not suitable in UK over 9200kg due to minimum tread width requirement of 300mm

Heavy Goods Vehicle Inspection Manual

07 Size and Type of Tyres								
Application								
TABLE 4 MAX AXLE LOADS FOR "UNRESTRICTED" SPEED VEHICLES								
Tyre load Index	Trailers permitted to exceed 50mph (up to 60mph)				Motor vehicles permitted to exceed 60mph (up to 70mph)			
	Speed Symbol F (-15%)		Speed Symbol G (-5%)		Speed Symbol J (-7%)		Speed Symbol K (-3%)	
	Single Kg	Dual Kg	Single Kg	Dual Kg	Single Kg	Dual Kg	Single Kg	Dual Kg
70	570	1140	640	1280	630	1250	650	1300
71	590	1180	660	1320	650	1290	670	1340
72	610	1210	680	1350	660	1330	690	1380
73	630	1250	700	1390	680	1360	710	1420
74	640	1280	720	1430	700	1400	730	1460
75	660	1320	740	1480	720	1440	760	1510
76	680	1360	760	1520	750	1490	780	1560
77	700	1410	790	1570	770	1540	800	1600
78	730	1450	810	1620	800	1590	830	1650
79	750	1490	830	1670	820	1630	850	1700
80	770	1530	860	1710	840	1680	880	1750
81	790	1580	880	1760	860	1720	900	1800
82	810	1620	910	1810	890	1770	930	1850
83	830	1660	930	1860	910	1820	950	1890
84	850	1700	950	1900	930	1860	970	1940
85	880	1760	980	1960	960	1920	1000	2000
86	910	1810	1010	2020	990	1980	1030	2060
87	930	1860	1040	2080	1020	2030	1060	2120
88	960	1910	1070	2130	1050	2090	1090	2180
89	990	1980	1110	2210	1080	2160	1130	2250
90	1020	2040	1140	2280	1120	2240	1170	2330
91	1050	2100	1170	2340	1150	2290	1200	2390
92	1080	2150	1200	2400	1180	2350	1230	2450
93	1110	2210	1240	2470	1210	2420	1270	2530
94	1140	2280	1280	2550	1250	2500	1300	2600
95	1180	2350	1320	2630	1290	2570	1340	2680
96	1210	2420	1350	2700	1330	2650	1380	2760
97	1250	2490	1390	2780	1360	2720	1420	2840
98	1280	2550	1430	2850	1400	2790	1460	2910

Heavy Goods Vehicle Inspection Manual

07 Size and Type of Tyres								
Application								
TABLE 4 (continued) MAX AXLE LOADS FOR "UNRESTRICTED" SPEED VEHICLES								
Tyre load Index	Trailers permitted to exceed 50mph (up to 60mph)				Motor vehicles permitted to exceed 60mph (up to 70mph)			
	Speed Symbol F (-15%)		Speed Symbol G (-5%)		Speed Symbol J (-7%)		Speed Symbol K (-3%)	
	Single Kg	Dual Kg	Single Kg	Dual Kg	Single Kg	Dual Kg	Single Kg	Dual Kg
99	1320	2640	1480	2950	1450	2890	1510	3010
100	1360	2720	1520	3040	1490	2980	1560	3110
101	1410	2810	1570	3140	1540	3070	1610	3210
102	1450	2890	1620	3230	1590	3170	1650	3300
103	1490	2980	1670	3330	1630	3260	1700	3400
104	1530	3060	1710	3420	1680	3350	1750	3500
105	1580	3150	1760	3520	1730	3450	1800	3590
106	1620	3230	1810	3610	1770	3540	1850	3690
107	1660	3320	1860	3710	1820	3630	1900	3790
108	1700	3400	1900	3800	1860	3720	1940	3880
109	1760	3510	1960	3920	1920	3840	2000	4000
110	1810	3610	2020	4030	1980	3950	2060	4120
111	1860	3710	2080	4150	2030	4060	2120	4230
112	1910	3810	2130	4260	2090	4170	2180	4350
113	1960	3910	2190	4370	2140	4280	2240	4470
114	2010	4020	2250	4580	2200	4390	2290	4580
115	2070	4140	2310	4620	2260	4520	2360	4720
116	2130	4250	2380	4750	2330	4650	2430	4850
117	2190	4370	2450	4890	2390	4780	2500	4990
118	2250	4490	2510	5020	2460	4910	2570	5130
119	2320	4630	2590	5170	2530	5060	2640	5280
120	2380	4760	2660	5320	2610	5210	2720	5440
121	2470	4930	2760	5510	2700	5400	2820	5626
122	2550	5100	2850	5700	2790	5580	2910	5820
123	2640	5270	2950	5890	2890	5770	3010	6020
124	2720	5440	3040	6080	2980	5960	3110	6210
125	2810	5610	3140	6270	3070	6140	3210	6410

Heavy Goods Vehicle Inspection Manual

07 Size and Type of Tyres								
Application								
TABLE 4 (continued) MAX AXLE LOADS FOR "UNRESTRICTED" SPEED VEHICLES								
Tyre load Index	Trailers permitted to exceed 50mph (up to 60mph)				Motor vehicles permitted to exceed 60mph (up to 70mph)			
	Speed Symbol F (-15%)		Speed Symbol G (-5%)		Speed Symbol J (-7%)		Speed Symbol K (-3%)	
	Single Kg	Dual Kg	Single Kg	Dual Kg	Single Kg	Dual Kg	Single Kg	Dual Kg
126	2890	5780	3230	6460	3170	6330	3300	6600
127	2980	5950	3330	6650	3260	6510	3400	6790
128	3060	6120	3420	6840	3350	6700	3500	6990
129	3150	6290	3520	7030	3450	6890	3590	7180
130	3230	6460	3610	7220	3540	7070	3690	7380
131	3320	6630	3710	7410	3630	7260	3790	7570
132	3400	6800	3800	7600	3720	7440	3880	7760
133	3510	7010	3920	7830	3840	7670	4000	8000
134	3610	7210	4030	8060	3950	7890	4120	8230
135	3710	7420	4150	8290	4060	8110	4230	8460
136	3810	7620	4260	8520	4170	8340	4350	8700
137	3910	7820	4370	8740	4280	8560	4470	8930
138	4020	8030	4490	8970	4390	8780	4580	9160
139	4140	8270	4620	9240	4520	9040	4720	9430
140	4250	8500	4750	9500	4650	9300	4850	9700
141	4380	8760	4900	9790	4790	9580	5000	10000
142	4510	9010	5040	10070	4930	9860	5150	10290
143	4640	9270	5180	10360	5070	10140	5290	10580
144	4760	9520	5320	10640	5210	10420	5420	10870
145	4930	9860	5510	11020	5400	10790	5630	11260
146	5100	10200	5700	11400	5580	11160	5820	11640
147	5230	10460	5850	11690	5720	11440	5970	11940
148	5360	10710	5990	11970	5860	11720	6120	12230
149	5530	11050	6180	12350	6050	12090	6310	12610
150	5700	11390	6370	12730	6240	12470	6500	13000
151	5870	11730	6560	13110	6420	12840	6700	13390
152	6040	12070	6750	13490	6610	13210	6890	13780
153	6210	12140	6940	13870	6790	13580	7090	14170

Heavy Goods Vehicle Inspection Manual

07 Size and Type of Tyres								
Application								
TABLE 4 (continued) MAX AXLE LOADS FOR "UNRESTRICTED" SPEED VEHICLES								
Tyre load Index	Trailers permitted to exceed 50mph (up to 60mph)				Motor vehicles permitted to exceed 60mph (up to 70mph)			
	Speed Symbol F (-15%)		Speed Symbol G (-5%)		Speed Symbol J (-7%)		Speed Symbol K (-3%)	
	Single Kg	Dual Kg	Single Kg	Dual Kg	Single Kg	Dual Kg	Single Kg	Dual Kg
154	6380	12750	7130	14250	6980	13950	7280	14550
155	6590	13180	7370	14730	7210	14420	7520	15040
156	6800	13600	7600	15200	7440	14880	7760	15520
157	7020	14030	7840	15680	7680	15350	8010	16010
158	7230	14450	8080	16150	7910	15810	8250	16490
159	7440	14880	8320	16630	8140	16280	8490	16980
160	7650	15300	8550	17100	8370	16740	8730	17460
161	7870	15730	8790	17580	8610	17210	8980	17950
162	8080	16150	9030	18050	8840	17670	9220	18430
163	8290	16580	9270	18530	9070	18140	9460	18920
164	8500	17000	9500	19000	9300	18600	9700	19400
165	8760	17510	9790	19570	9580	19160	10000	19990
166	9010	18020	10070	20140	9860	19720	10290	20570
167	9270	18530	70360	20710	10140	20280	10580	21150
168	9520	19040	10640	21280	10420	20840	10870	21730
169	9860	19720	11020	22040	10790	21580	11260	22510
170	10200	20400	11400	22800	11160	22320	11640	23280
171	10460	20910	11690	23370	11440	22880	11940	23870
172	10710	21420	11970	23940	11720	23440	12230	24450
173	11050	22100	12350	24700	12090	24180	12610	25220
174	11390	22780	12730	25460	12470	24930	13000	26000
175	11730	23460	13110	26220	12840	25670	13390	26780
176	12070	24140	13490	26980	13210	26420	13780	27550
177	12410	24820	13870	27740	13580	27160	14170	28330
178	12750	25500	14250	28500	13950	27900	14550	29100
179	13180	26350	14730	29450	14420	28830	15040	30070

If axle loads for 'unrestricted' speed vehicles are required - contact Driver and Vehicle Standards Agency, Ellipse, Padley Road, Swansea SA1 8AN.

**07 Size and Type of Tyres
Application**

REPRODUCED BY COURTESY OF THE BRITISH RUBBER MANUFACTURERS ASSOCIATION

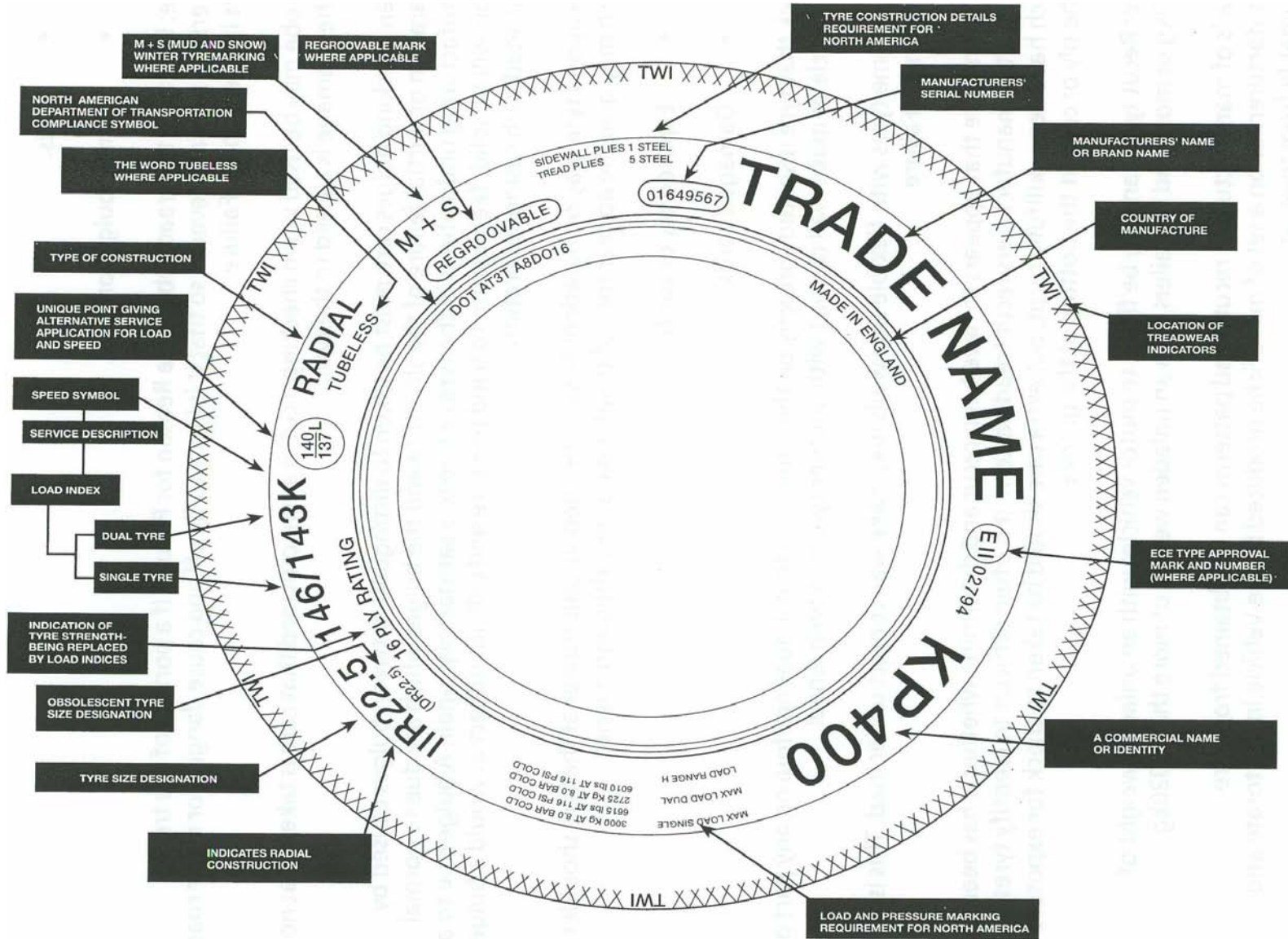

A tyre may not necessarily carry all of the markings.

07 Size and Type of Tyres	
Method of Inspection	Reason for Failure
<p>1. Check each tyre to ensure:</p> <ul style="list-style-type: none"> a. the nominal size; ply rating, load index or speed rating of any tyre is appropriate for the plated axle weight. b. the tyre use marking is appropriate for the type of axle or vehicle to which it is fitted. c. the nominal size of a tyre to any other on the same axle. d. the structure of a tyre to any other on the same axle. e. the structure on a steerable axle is of the same structure as any other tyre on any steerable axle. f. the structure on a drive axle is of the same structure as any other tyre on any driven axle. <p>2. Check on a two axle motor vehicle fitted with single tyres on both axles the combination of tyres with structures which are shown as acceptable in the table.</p>	<p>1. A tyre:</p> <ul style="list-style-type: none"> a. of which the nominal size, ply rating, load index or speed rating of any tyre is below that appropriate for the plated axle weight. b. which has a tyre use marking inappropriate for the type of axle or vehicle to which it is fitted. c. of a different nominal size to another on the same axle. d. of a different structure to another on the same axle. e. on a steerable axle which is not of the same structure as any other tyre on any steerable axle. f. on a driven axle which is not of the same structure as any other tyre on any driven axle. <p>2. On a two axle motor vehicle fitted with single tyres on both axles a combination of tyres with structures which are not shown as acceptable in the table.</p>

08 Condition of Tyres
Application

This examination applies to all tyres fitted to vehicles and trailers apart from spare tyres.

Lifting of the tread rubber is a Reason for Failure.

If a portion of the tread material is partially severed so that it is likely to fly off and cause danger for other road users it is a Reason for Failure.

A probe may be used when checking a cut in a tyre for exposed ply or cords provided that care is taken that no further damage is caused to the tyre. Exposed, for this purpose, means the cords are visible as seen with the naked eye (RfF 1c) or in the case of a cut more than 25mm or 10% of the section width, can be made visible with the use of a probe (RfF 1a).

Where a cut in a tyre requires the use of a probe to check for cord exposure remember, if during investigation cords can be felt but not seen, **pass & advise**. A cut which is deep enough to expose the ply or cords, and is more than 25mm long, or 10% of the section width, whichever is greater should fail under RfF 1a (the overriding factor is that the cords themselves must be exposed not merely felt).

When checking bulges care must be taken to distinguish between bulges caused by separation or partial failure of the structure and the bulges which are due to normal manufacturing undulations in the tyre or due to a satisfactory repair. A bulge due to a repair will be solid, feeling firm to hand pressure and will not deflect as would a bulge associated with casing separation.

A recapped tyre may on occasions have unbonded surplus rubber at the tyre shoulder which may give the appearance of tread separation, although it is not.

Some tyres with flexible side walls may show signs of wall contact under load, this is not a Reason for Failure.

When checking any tyre that appears to have been recut, it must be determined whether it has been recut to the manufacturers recut tread pattern. It is often difficult to identify tyres which have been skilfully recut, but extra care should be taken to check for exposure of the ply or cord at the bottom of the grooves.

Recut tyres can only be fitted to motor vehicles with an unladen weight of 2540kg or more and to trailers with an unladen weight of more than 1020kg.

08 Condition of Tyres

Application

Details of manufacturers' recut tread patterns can be obtained either from the DVSA internal Intranet or the Driver and Vehicle Standards Agency, Technical Services, Ellipse, Swansea, SA1 8AN.

The original tread pattern means:

- On a re-treaded tyre the tread pattern immediately after the tyre was retreaded.
- On a recut tyre the manufacturer's recut tread pattern.
- On a partly recut tyre, the part which has been recut the manufacturer's recut tread pattern, on the other part the tread pattern when new.
- On any other tyre the tread pattern of the tyre when new.

When checking the tread pattern the "Breadth of Tread" is to be taken as that part of the tyre which can contact the road, under normal use, measured across the tyre.

The following should be disregarded when deciding which grooves need to be checked in regard to the "original tread pattern".

- Grooves which wear out before the main grooves are worn.
- Other minor features such as sipes, small lateral extensions to the circumferential grooves and minor lateral grooving on the shoulders.

Minimum tread depths applicable are shown in the table below:

Design gross weight of vehicle or trailer	Over 3500kg	3500kg or less
Minimum tread depth	1mm, excluding any tie bar or tread wear indicator	1.6mm, excluding any tie bar or tread wear indicator
Position of minimum tread depth band	Form a continuous band covering at least any 3/4 of the breadth of the tread around the entire circumference	Form a continuous band covering the central 3/4 of the breadth of the tread around the entire circumference

The following diagrams show acceptable positions of the minimum tread depth band, for vehicles over 3500kg design gross weight, which must be measured at right angles to the axis of the wheel. Figures 1-4 show cambered wear and Figure 5 shows more detail of how the tread band is measured. For vehicles of 3500kg or less the band is the central 3/4 of the breadth of tread and it is not necessary for tread depth to be visible on the remainder.

Figure 6 shows that for certain cross country tyres that may be necessary to accept that the band of acceptable tread pattern may include a plain portion in the centre.

08 Condition of Tyres
Application

Figures (1), (2), (3) and (4) T= Breadth of Tread
 $\frac{3}{4}$ T = Minimum width of continuous band.

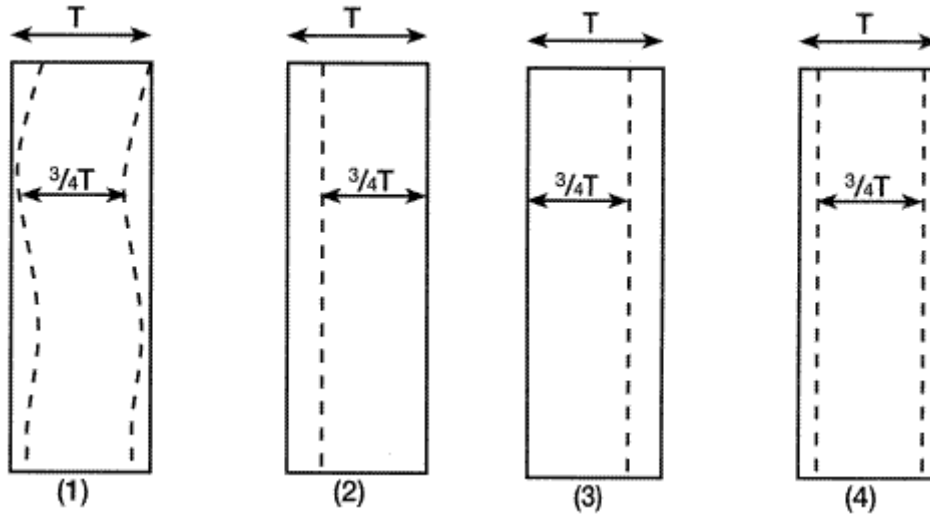
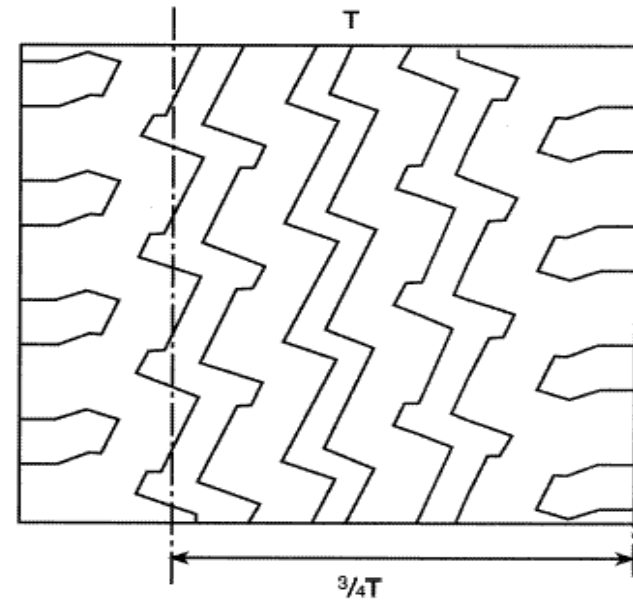

Fig 5



In this case the lateral grooves are the same depth as the circumferential groove and are included in the $\frac{3}{4}$ measurement.

The breadth of the tread is 'T'.

The $\frac{3}{4}$ of 'T' measurement can be taken over 'T' as in figure 1 to 4.

08 Condition of Tyres
Application

Fig 6

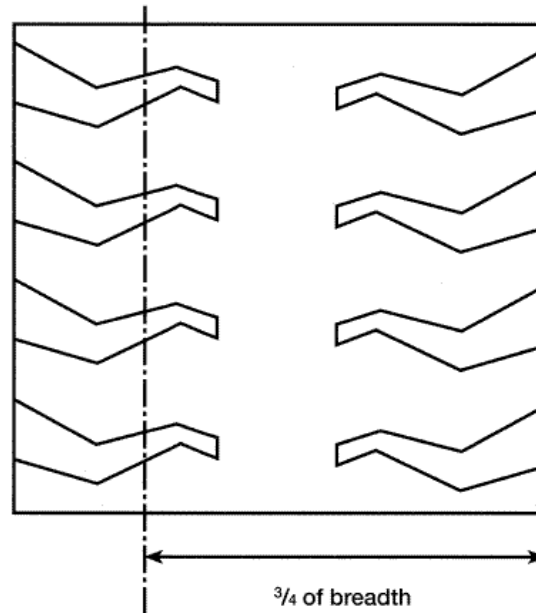

This tyre only has lateral grooving

The band of acceptable tread pattern includes the plain portion which existed when the tyre was new. The remaining tread area should contain grooves to the depth of 1 mm.

08 Condition of Tyres	
Method of Inspection	Reason for Failure
<p>1. Check each tyre for:</p> <ul style="list-style-type: none"> a. cuts. b. lumps, bulges or tears. c. exposed ply or cords. d. fouling on any part of the vehicle. e. correct seating on the wheel. f. wall contact with another tyre on a twin wheel. g. the base of any groove of the original tread pattern is clearly visible. h. the minimum tread depth and tread band requirement. <p>2. Check recut tyres:</p> <ul style="list-style-type: none"> a. fitted to a vehicle are legally acceptable. b. to ensure the wholly or partly recut tread pattern is to the manufacturer's recut tread pattern. 	<p>1. A tyre</p> <ul style="list-style-type: none"> a. with a cut which is deep enough to reach the ply or cords, and is more than 25mm long, or 10% of the section width, whichever is greater. **b. with a lump, bulge or tear caused by separation or partial failure of its structure, including any lifting of the tread rubber. *c. with exposed ply or cord. d. fouling on any part of the vehicle. e. incorrectly seated on its wheel. f. on a twin wheel making wall contact with another tyre. g. where the base of any groove of the original tread pattern is not clearly visible (vehicles with DGWV greater than 3500kg). *h where the minimum tread depth and tread band requirements are not met. <p>2. A recut tyre:</p> <ul style="list-style-type: none"> a. fitted to a vehicle which should not have one. b. on which the wholly or partly recut tread pattern is not to the manufacturer's recut tread pattern.

09 Sideguards, Rear Under-Run Devices & Bumper Bars**Application****SIDEGUARDS**

Sideguards can be manufactured & tested to any of the following standards:

The Road Vehicles (Construction and Use) Regulations 1986 as amended. Directive 89/297/EEC or The technical requirements of the Directive 89/297/EEC.

Sideguards are applicable to:

Motor Vehicles first used from 1 April 1984 with a design gross weight exceeding 3,500kg and where the distance between the centres of any two consecutive axles exceeds 3m;

Trailers manufactured from 1 May 1983 with an unladen weight exceeding 1,020kg and where the distance between the centres of any two consecutive axles exceeds 3m; or in the case of a semi-trailer, where the distance between the centre of the kingpin position and the centre of the foremost axle exceeds 4.5m.

Semi-Trailers manufactured before 1 May 1983 which have a design gross weight exceeding 26,000kg and which form part of an articulated vehicle with a design gross train weight exceeding 32,520kg and where the distance between the centre of the kingpin and the centre of the foremost axle exceeds 4.5m. Where more than one kingpin is fitted, it is the distance from the rearmost position which is taken into account.

Exempted Vehicles:

- A vehicle or trailer constructed so that it can be unloaded by part of the vehicle being tipped sideways or rearwards.
- A vehicle or trailer designed solely for use in connection with street cleaning, the collection/disposal of refuse or the contents of gullies/cesspools. (Skip carrying vehicles are classed as refuse vehicles and as such are exempt).
- A trailer specially designed and constructed, and not merely adapted, to carry round timber, beams or girders, being items of exceptional length.
- Tractor units.
- A vehicle or trailer specially designed and constructed, and not merely adapted, to carry other vehicles loaded onto it from the front or rear (*Vehicles with a standard flat body fitted with a "beaver tail" are not exempt*).
- A trailer with a load platform which is not more than 750mm from the ground throughout that part of its length under which a sideguard would have to be fitted.
- A semi-trailer incorporating a sliding bogie.

09 Sideguards, Rear Under-Run Devices & Bumper Bars

Application

Exempted Vehicles (continued):

- A **rigid motor vehicle** or **trailer** designed for and constructed for the special purpose of carrying long (but not exceptionally long) timbers from an off road location in a forest.

To fulfil this definition the vehicle must meet the following criteria:

- a. It must be of skeletal construction.
- b. It must have a minimum of two upright side supports (sidebolsters) fitted to each side of the vehicle.
- c. It must not be fitted with a load platform, other than chassis rails, cross bearers and the minimum amount of flooring necessary to protect wiring or brake line components.

It is permissible for the vehicle to be fitted with the following:

- Loading equipment i.e. a Hiab crane or similar device.
- Cross bearers that do not have upright side supports.

This list is not exhaustive but covers the vehicles likely to be encountered within the testing scheme.

Vehicles equipped with cranes, it is not practicable to fit sideguards in the area of the crane and its controls. Before reaching a decision on its pass/fail criteria for vehicles/trailers you need to take account of the following;

Vehicles fitted with an extendible device or leg to provide stability during loading, and equipped with loading devices and controls, which makes it impracticable to fully comply with the sideguard legislation, will be deemed compliant provided sideguards are in place to the fullest extent practicable. All vehicles must be presented for statutory test with any such devices in the stowed position.

Vehicles with access and a working platform adjacent to, and necessary for, the operation of a loading device, shall be regarded as a load carrying platform for sideguard compliance forward of the extendible device or leg.

Acceptable circumstances are when other items on the vehicle such as fuel tanks, work boxes etc which by virtue of their shape and characteristics conform to the requirements of a sideguard.

Trailers manufactured before 1 May 1983 will not be failed if sideguards are not fitted, but the driver/operator notified that they may be required under certain circumstances.

09 Sideguards, Rear Under-Run Devices & Bumper Bars

Application

Sideguards fitted to vehicles/trailers that do not require them will only be checked for items (a), (c) and (g) in Mol 2.

The continuous vertical rail or turn in may not be required if the front edge of the sideguard is within 100mm of a permanent structure of the vehicle (vehicle cab/wheel arch).

REAR UNDER-RUN DEVICES

Rear under-run devices are applicable for motor vehicles with a gross design weight exceeding 3,500kg and first used from 1 April 1984; or

Trailers manufactured from 1 May 1983 with an unladen weight exceeding 1,020kg

Exempted vehicles:

- Tractor units.
- A vehicle or trailer fitted at the rear with apparatus specially designed for spreading material on a road.
- A vehicle or trailer so constructed that it can be unloaded by part of the vehicle being tipped rearwards.
- A vehicle or trailer specially designed and constructed, and not merely adapted, to carry other vehicles loaded onto it from the rear. (Vehicles with a standard flat body fitted with a “beaver tail” are not exempt.)
- A trailer specially designed and constructed, and not merely adapted, to carry round timber, beams or girders, being items of exceptional length.
- A vehicle or trailer fitted with a tail lift so constructed that a lift platform, with a minimum length of 1m, forms part of the floor of the vehicle.
- A vehicle specially designed, and not merely adapted, for the carriage and mixing of concrete.

This list is not exhaustive but covers the vehicles likely to be encountered within the testing scheme.

If a vehicle has a rear tail lift, where the rear uprights for the tail lift are separated from the rear under-run, the uprights are not to be taken as part of the under-run device.

Vehicles equipped with rear tail lifts are allowed to have gaps between the rear under-run rails. Gaps are permitted up to 500mm between rear under-run rails.

Vehicles with tail lifts may be fitted with a guard up to 300mm wider than the outer edge of the outermost rear tyre provided it is no wider than the outer edge of the vehicle.

09 Sideguards, Rear Under-Run Devices & Bumper Bars

Application

Vehicles not required to be fitted with a rear under-run device but having one fitted are only to be inspected as if it was a bumper bar.

Where a rear under-run extends outside the width of the outermost rear tyre but is joined to a sideguard positioned to the rear of the tyre, this is not a RfF.

Vehicles that have two rear axles where the rearmost one has a narrower track, the sideguard criteria needs to comply with the widest of the rear axles.

Vehicles with bodies that satisfy the dimensional requirements for rear under-run devices are considered acceptable.

It is acceptable for a rigid vehicle to be presented for annual test without a rear under-run device fitted when towing a trailer. However, the under-run device must be readily available for use when not towing a trailer.

BUMPER BARS

This inspection applies to all vehicles and trailers.

Vehicles are not required to have separate bumper bars, these may be incorporated into the body in some cases.

Further sideguard Information

Construction

- The guard should be as continuous as possible and the outermost surface smooth, essentially rigid and either flat or horizontally corrugated, but can be split into rails. Rails must be flat faced on the outside, (N2/O3 vehicles/trailers) minimum 50mm, (N3/O4 vehicle/trailers) minimum 100mm (but can be wider), and the distance between them not more than 300mm. Parts of the guard may be detachable for access, but must be securely fixed when the vehicle is in use.
- The front edge of the guard must have a continuous surface extending back for (N2/O3 vehicles/trailers) minimum 50mm; (N3/O4 vehicle/trailers) minimum 100mm, for both ranges of vehicles the turning inwards is 100mm.
- On occasions a single rail may fulfil this requirement and it will be sufficient that the forward face only covers the depth of the rail.

N₂ vehicles are vehicles over 3500kg but does not exceed 12000kg DGVW.

N₃ vehicles are vehicles that exceed 12000kg DGVW.

O₃ trailers are trailers over 3500kg but does not exceed 10,000kg TAW.

O₄ trailer are trailers which exceed 10,000kg TAW.

DGVW = Design Gross Vehicle Weight TAW = Total Axle Weight

09 Sideguards, Rear Under-Run Devices & Bumper Bars

Application

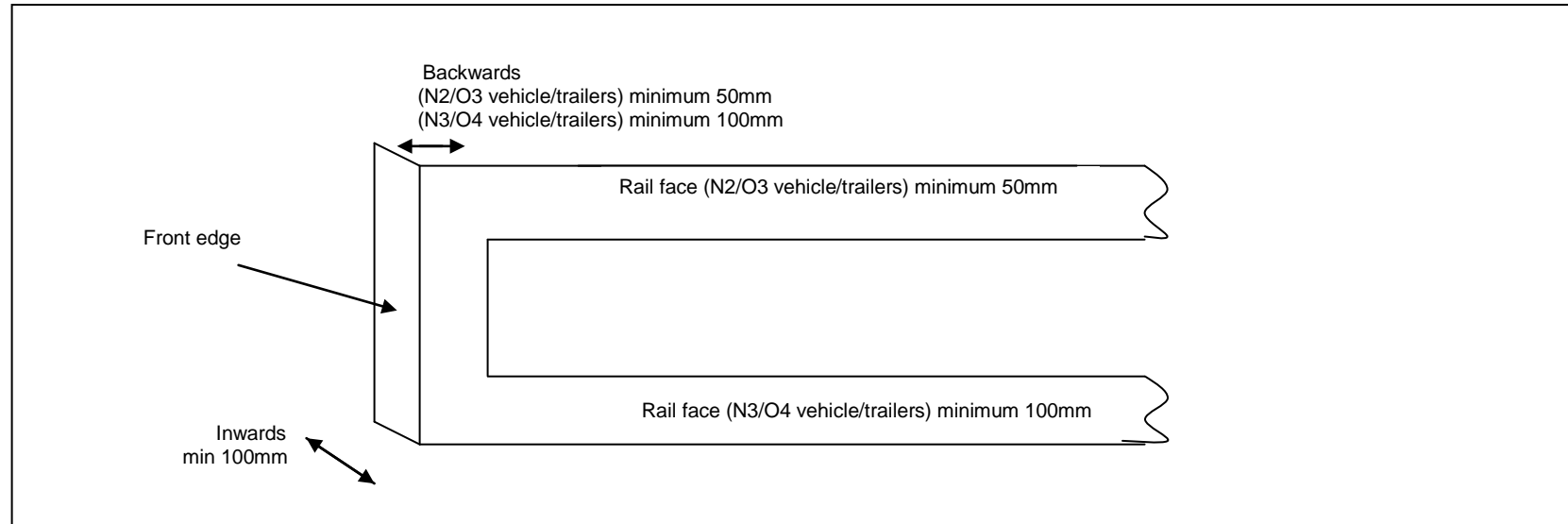

Distance of Guard from Front Wheels (or landing legs) and Rear Wheels

Motor Vehicles

The front edge of the guard must not be more than 300mm from the tyre on the front wheel (or second wheel if two front axles) and the guard must extend to within 300mm of the tyre on the first rear axle.

Draw-Bar Trailer

The front edge of the guard must not be more than 500mm from the tyre on the front wheel and the guard must extend to within 300mm of the tyre on the rear wheel.

Semi-Trailer

The front edge of the guard can be up to 250mm behind the centre line of the landing legs, but never more than 3m behind the centre of the king pin (in its rearmost position) and the guard must extend to within 300mm of the tyre on the first rear axle.

09 Sideguards, Rear Under-Run Devices & Bumper Bars

Application

Minimum Height to Top Edge

To determine the height to the top edge, it is necessary to imagine a vertical plane parallel to the vehicle centre line and just touching the outer edge of the outermost rear tyre (neglecting the bulge). The line where the vertical plane cuts the structure of the vehicle is taken as the datum and may not be straight, but will move up and down as the plane cuts through transverse floor members etc.

The upper edge of a sideguard shall not be more than 350mm below that part of the structure of the vehicle, cut or contacted by a vertical plane tangential to the outer surface of the tyres, excluding any bulging close to the ground except in the following cases.

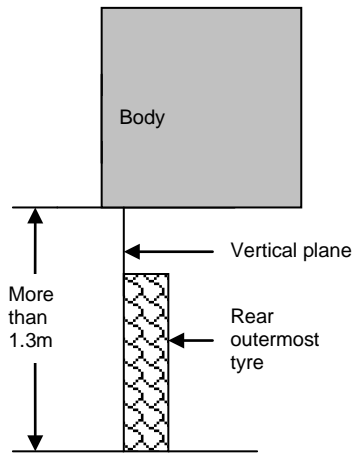

Where the tangential plane cuts the structure of the vehicle at more than 1.3m above the ground, then the upper edge of the sideguard shall not be less than 950mm above the ground.

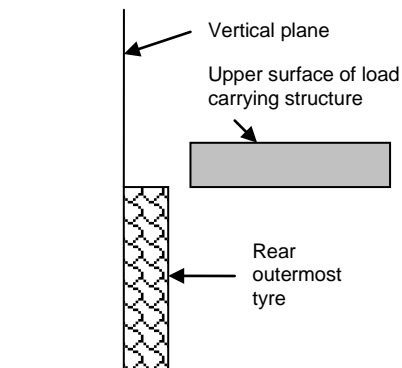

Where the tangential plane does not cut the structure of the vehicle, the upper edge shall be level with the surface of the load carrying platform, or 950mm from the ground, whichever is the less.

Tangential plane should be taken as a line from the outermost edge of the rear tyre(s) excluding the bulge due to the weight of the vehicle.

09 Sideguards, Rear Under-Run Devices & Bumper Bars

Application

Lateral Projection

The guard must not project beyond the outside edge of the vehicle, and it must not be more than 150mm inside the outermost plane of the vehicle (Maximum width). The last 250mm of the sideguard, at the rear, must be no more than 30mm from the outer edge of the outermost rear tyre.

Components in the Sideguard Area

In general, the regulations do not allow for the sideguard run to be broken, if components such as fuel tanks and air reservoirs intrude, the components should be sited such that they do not interfere with the sideguard run. However, components may be incorporated if, by virtue of their shape and characteristics, they conform in all respects to the sideguard requirements. Where the guard is not continuous from front to rear; adjacent parts can overlap provided that the overlapping edge faces rearwards or downwards; or a gap of not more than 25mm measured longitudinally may be left, provided that the rearward part does not protrude outboard of the forward part.

Note: Protrusions from such components within the sideguard run must conform to all the side guard requirements. Protrusions from these components not within the side guard run (i.e. between the sideguard gaps do not need to conform to the standards.

If the sides of the vehicle are so designed and/or equipped, that by virtue of their shape and characteristics the component parts together meet the requirements, they may be regarded as replacing the sideguards.

Where a vehicles body meets the dimensional requirements (dimensional being, min. & max. height from the ground, plus the distance from rear of front wheel or landing leg and front of rear wheel) for sideguards these will be deemed to be met, however where only part of the body meets the requirements, side guards must be fitted in the remaining appropriate areas.

Chassis Mounted Cranes

Where cranes are fitted across the chassis the extendible legs are normally stowed and operate through the sideguard run. The sideguard rail or rails are required to come within a distance of 130mm of the leg at each side, thus allowing working room. Before deciding on the pass/fail criteria, consideration must be given to the crane and platform explained on page 2 above.

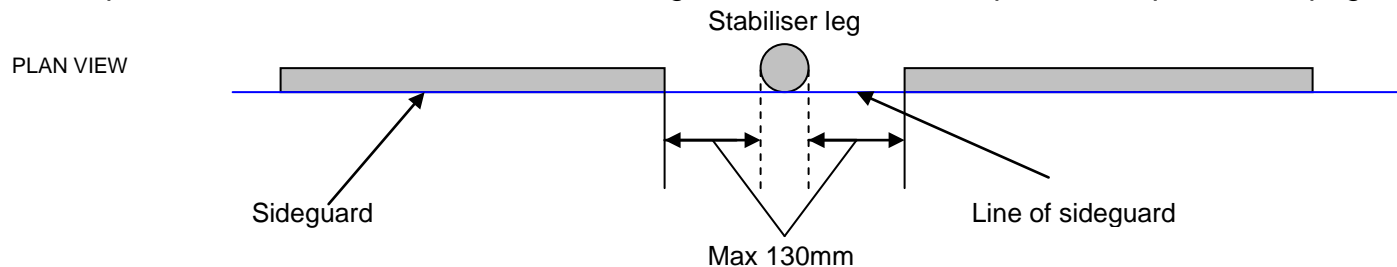

The diagram is only to illustrate the dimensions allowed between the stabiliser leg and a sideguard; it is not the intention that the stabiliser leg should be stowed in this position.

09 Sideguards, Rear Under-Run Devices & Bumper Bars

Application

Sideguard Material

There is no legislation regarding the materials used for sideguards although there are regulations covering strength and deflection of these components. None of these however are subject to test.

Protrusions

Protrusions (on the side guard outer faces) such as rivet or bolt heads are acceptable provided that they do not exceed 10mm and are suitably domed.

External corners and edges must be rounded.

Orange reflective strips are acceptable if fitted to sideguards provided that the front edge is rounded and it does not protrude more than 10mm.

Short Bodied Vehicles

Vehicles which have shortened bodies to facilitate the fitting of plant equipment usually have a large gap between the back of the cab and the body. There may therefore be a considerable length of sideguard area not covered by the body. In these cases the height of the guard covered by the body is the normal 350mm max below the structure, but the height of the guard in the area not covered by the body must be no lower than the body floor or 950mm whichever is the lowest and may require more than 1 rail.

Type Approved Sideguards

If the presenter claims that the vehicle or trailer is fitted with type approved sideguards (this will most often be on an imported trailer) which comply with the requirements of the EC directive, the presenter should be asked to provide documentary evidence. Although the standards are to accept sideguards made to the directive but not necessarily approved it may assist to identify those vehicles/trailers which are known to be approved, these are:

Trailer Make

Hellbender

Magyar

Model

EUT, KIP, KIS, TSA, MUL, CONC.

All models type approved.

Vehicle Make

Mercedes-Benz

Model

Atego.

09 Sideguards, Rear Under-Run Devices & Bumper Bars

Application

Tankers

It is recognised that there are practical problems in the fitting of sideguards to some tankers and there can be differing views over what constitutes "so far as is practicable".

A. Tankers which Convey Dangerous Substances

Vehicle Safety Division, the Society of Motor Manufacturers and Traders and the British Tank Manufacturers Technical Committee agreed on the design layout specification for sideguards on these vehicles. This agreement is summarised in the drawings that follow. In all other respects the guards must conform to the regulations.

**B. Skeletal Trailers Carrying Frameless Tanks
(i.e. a tank or container which does not have a lower side rail or rave).**

Sideguards fitted to skeletal trailers carrying frameless tanks must incorporate a top rail, the upper edge of which should be at least 950mm from the ground or to the height of the trailers upper tank carrying surface (e.g. twist locks) if this is less than 950mm.

C. Milk Tankers with External Cylindrical Tubes for Stowage of Hoses

An external cylindrical tube permanently fitted longitudinally to the side of a vehicle and intended for the stowage of a hose, can for the purpose of the sideguard positional requirements be considered part of the body.

This only applies to that side of the vehicle fitted with the cylindrical tube and where the tube completely extends over the length of the vehicle required to be fitted with sideguards. Any other type of hose support, e.g. rack or tray, should not be considered part of the bodywork.

D. Hose Racks

With the exception stated at "C" above, a hose rack fitted to a vehicle or trailer should be disregarded when making an assessment as to whether the body cuts the vertical plane as in the section dealing with Maximum Height to Top Edge.

It is however permissible for the hose rack to be taken as part of the sideguard if it meets the dimensional requirements.

**09 Sideguards, Rear Under-Run Devices & Bumper Bars
Application**

Figure 1

Fitting Sideguards to N/S when Battery Box and Meter Equipment Fitted.

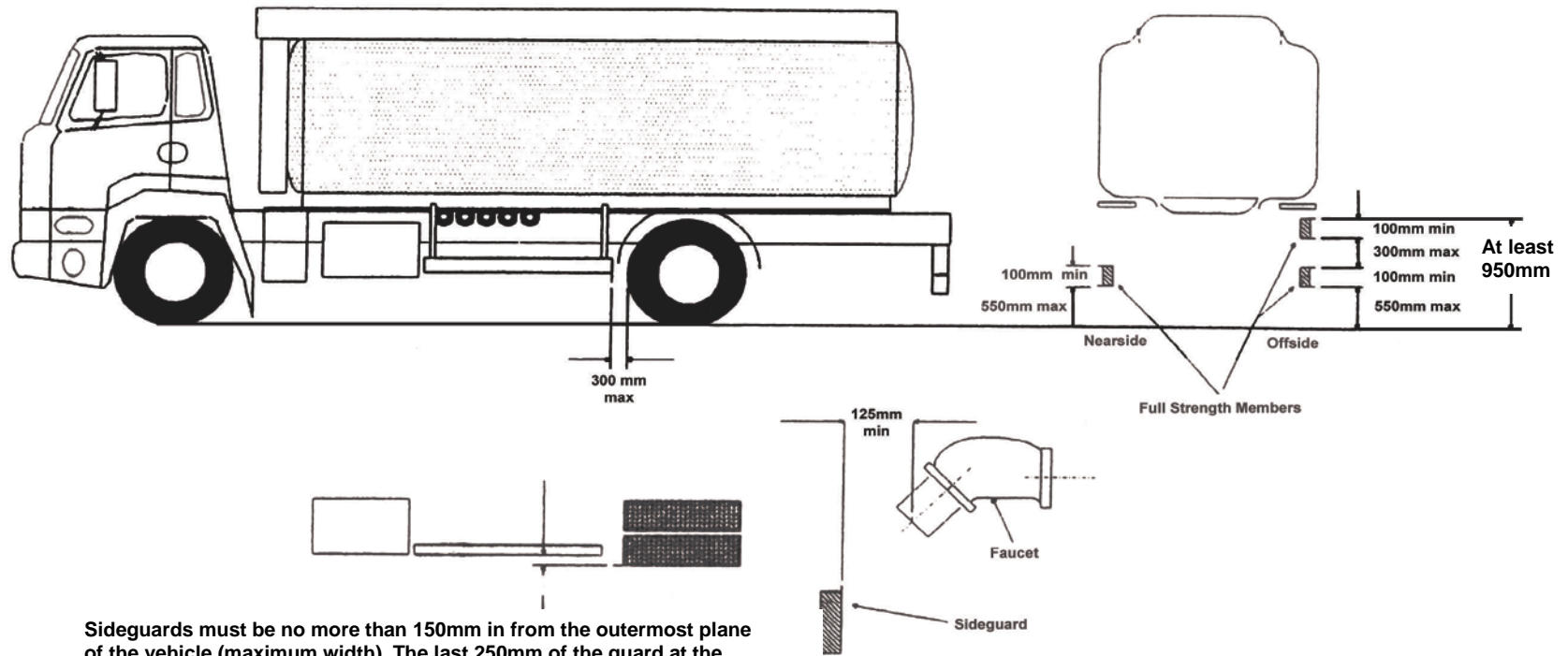

Sideguards must be no more than 150mm in from the outermost plane of the vehicle (maximum width). The last 250mm of the guard at the rear must be no more than 30mm from the tangential plane of the rear tyres.

**09 Sideguards, Rear Under-Run Devices & Bumper Bars
Application**

**Figure 2
Fitting Sideguards - Maximum Section Tanks - Side Outlets**

Typical spirit tanker shown rigid type 2,3 or 4 axle

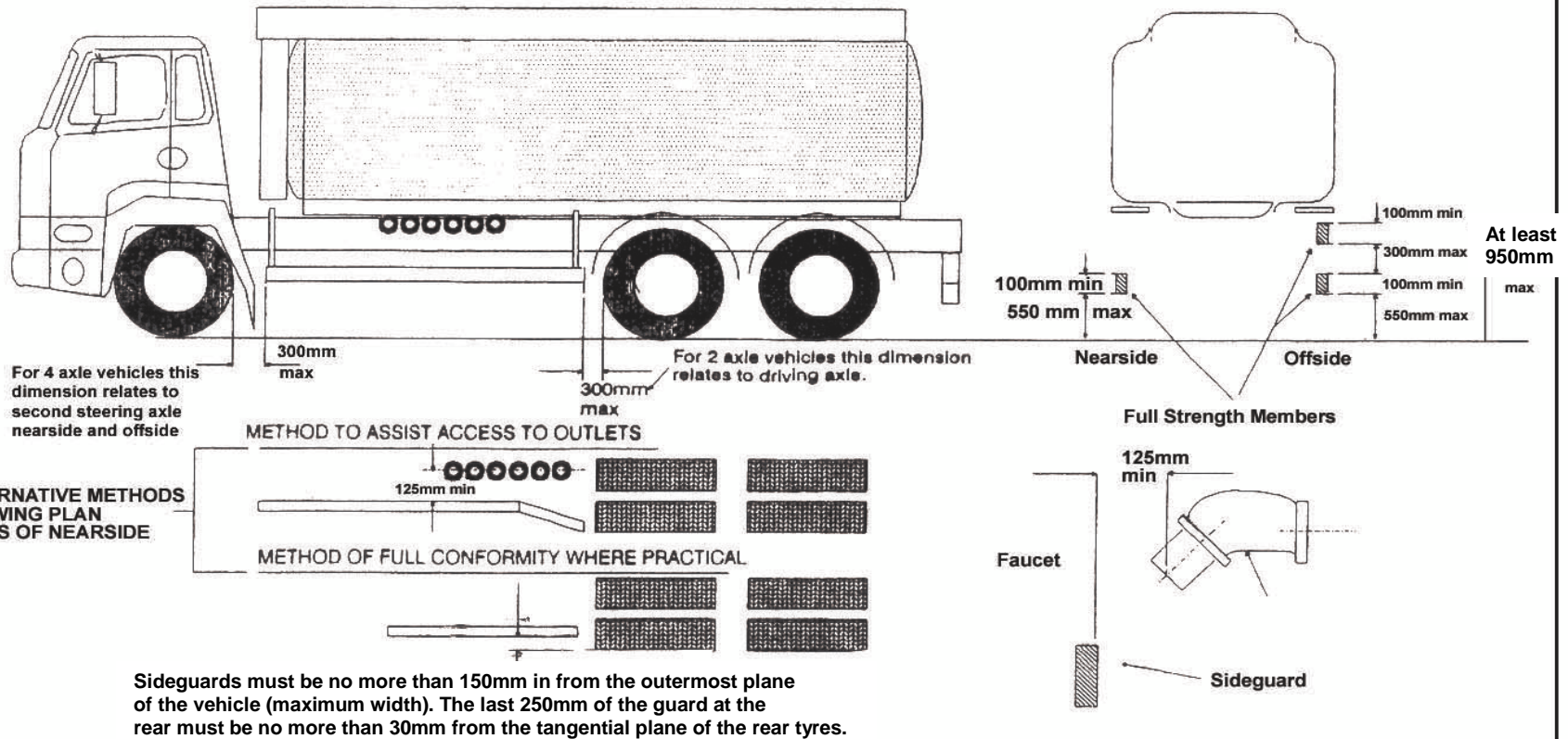

**09 Sideguards, Rear Under-Run Devices & Bumper Bars
Application**

Figure 3

Fitting Sideguards — **Maximum Section** **Tanks** — **Side Outlets** — **Side Ladder**
 — **Meter Box and Reel**

Typical spirit tanker shown rigid type 2, 3 or 4 axle

Ladders encroaching into the sideguard area must comply with the side guard regulations (not applicable to fluid tankers)

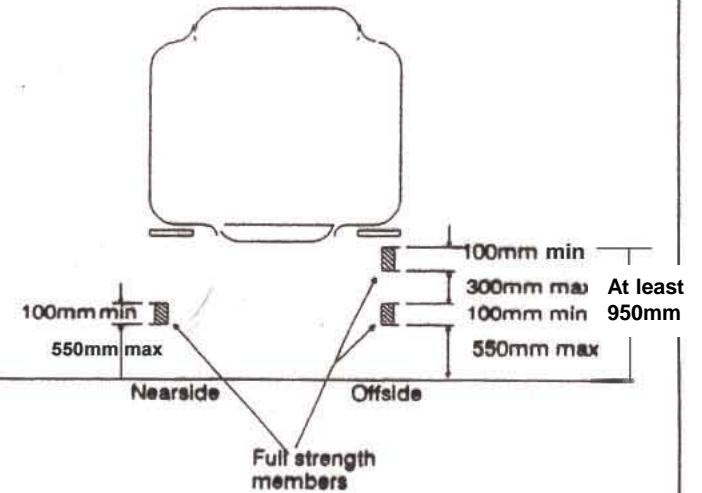
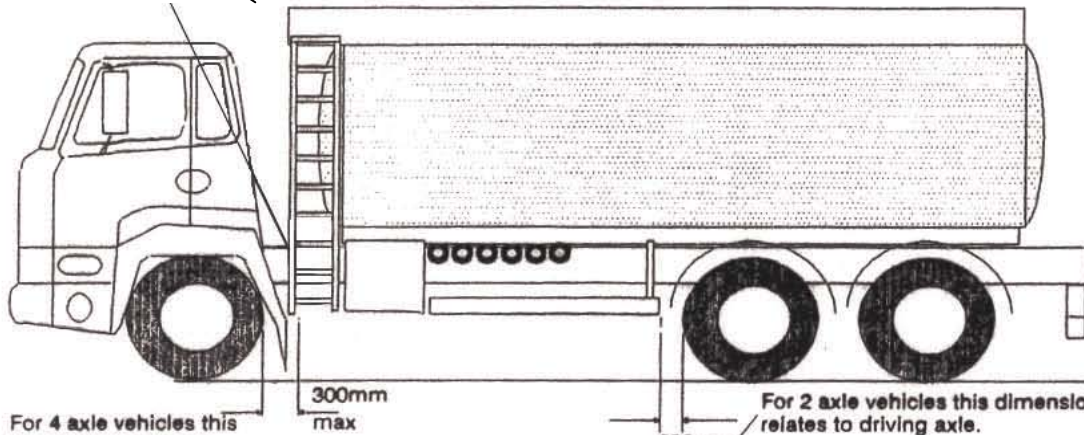

ALTERNATIVE METHODS SHOWING PLAN VIEWS OF NEAR SIDE

METHOD TO ASSIST ACCESS TO OUTLETS

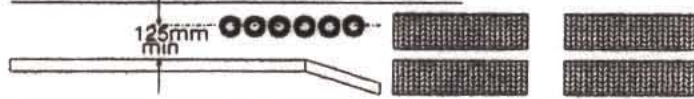

METHOD OF FULL CONFORMITY WHERE PRACTICAL

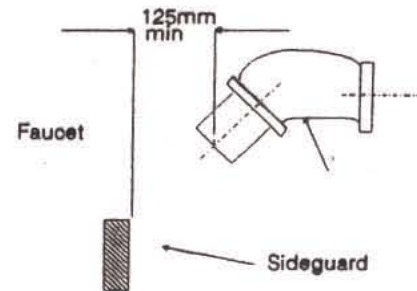
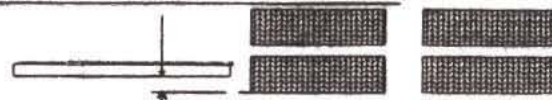

Sideguards must be no more than 150mm in from the outermost plane of the vehicle (maximum width). The last 250mm of the guard at the rear must be no more than 30mm from the tangential plane of the rear tyres.

**09 Sideguards, Rear Under-Run Devices & Bumper Bars
Application**

Figure 4

Fitting Sideguards — **Maximum Section** **Tanks** — **Side Outlets** — **Rear Ladder**
Meter Box and Reel

If battery box substantially fills the gap between the cab and the meter box sideguards can be omitted.

Typical spirit tanker shown rigid type 2, 3 or 4 axle

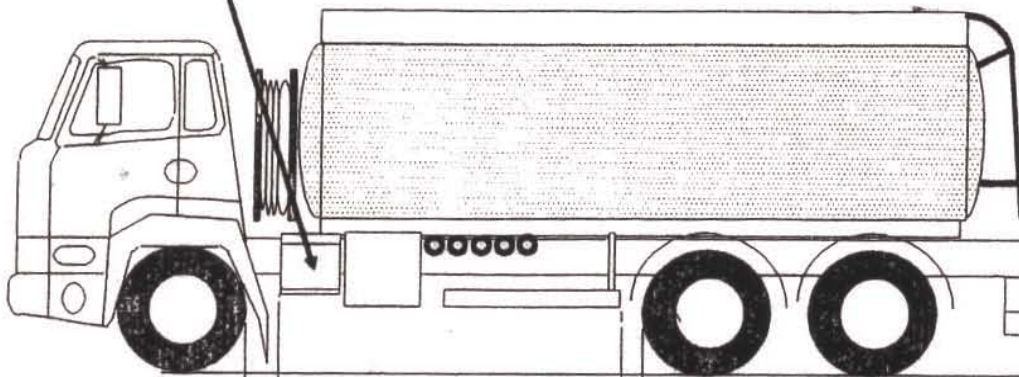

For 4 axle vehicles this dimension relates to second steering axle nearside and offside

300mm max

300mm max

For 2 axle vehicles this dimension relates to driving axle.

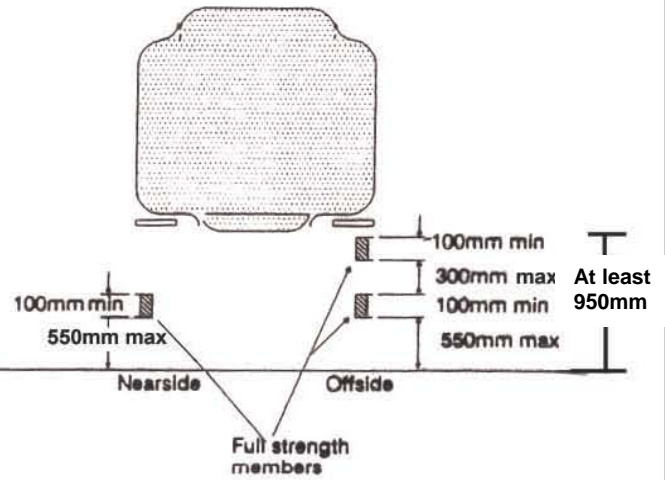

ALTERNATIVE METHODS SHOWING PLAN VIEWS OF NEAR SIDE

METHOD TO ASSIST ACCESS TO OUTLETS

METHOD OF FULL CONFORMITY WHERE PRACTICAL

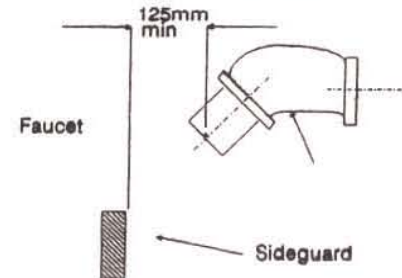
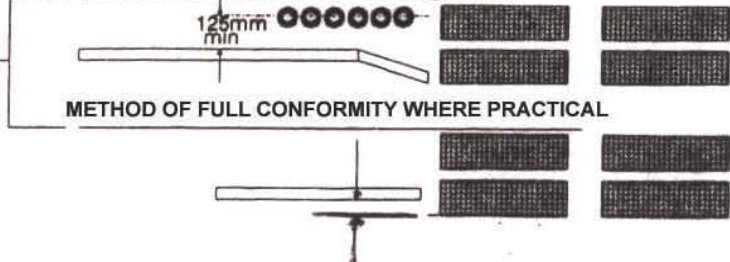

Sideguards must be no more than 150mm in from the outermost plane of the vehicle (maximum width). The last 250mm of the guard at the rear must be no more than 30mm from the tangential plane of the rear tyres.

**09 Sideguards, Rear Under-Run Devices & Bumper Bars
Application**

Figure 5

Fitting Sideguards — Narrow Section Tanks — Semi-trailer

Typical spirit tanker shown

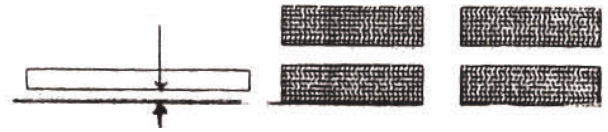
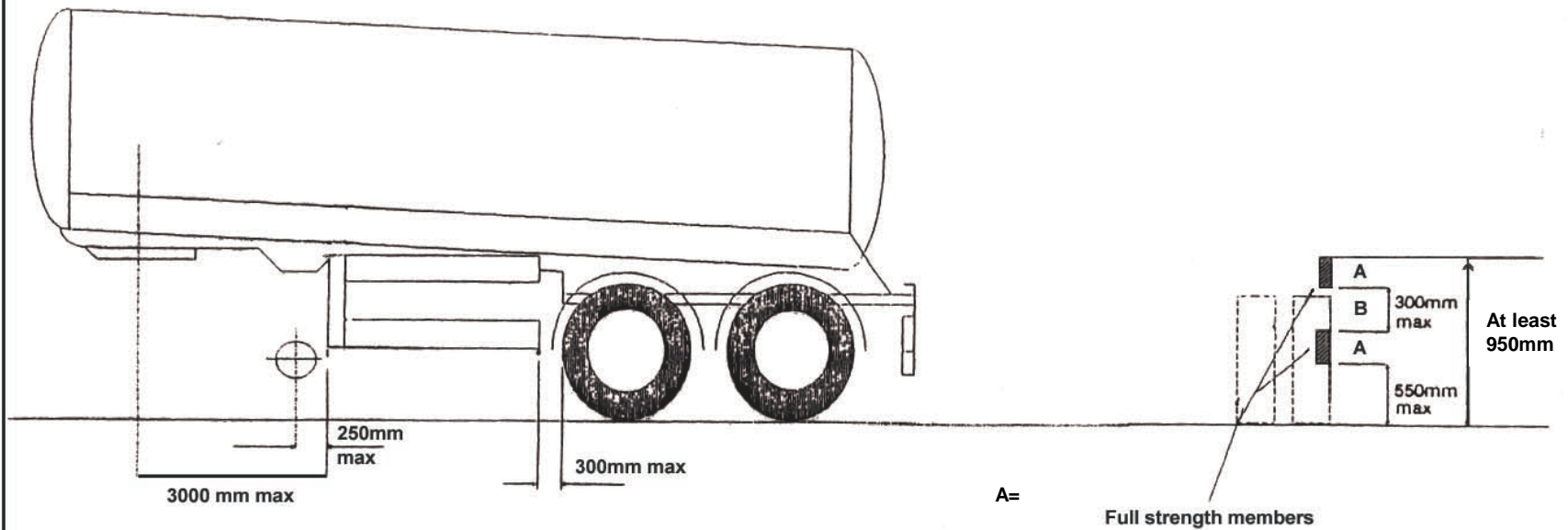

Sideguards must be no more than 150mm in from the outermost plane of the vehicle (maximum width). The last 250mm of the guard at the rear must be no more than 300mm from the tangential plane of the rear tyres.

**09 Sideguards, Rear Under-Run Devices & Bumper Bars
Application**

Figure 6

Fitting Sideguards — **Maximum Section Tanks** — **Semi-trailer**
 — **Side Outlet**
Typical spirit tanker shown

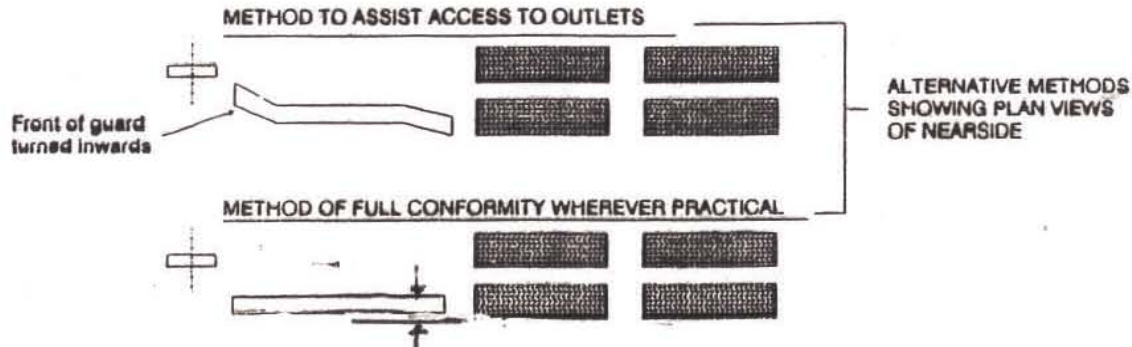
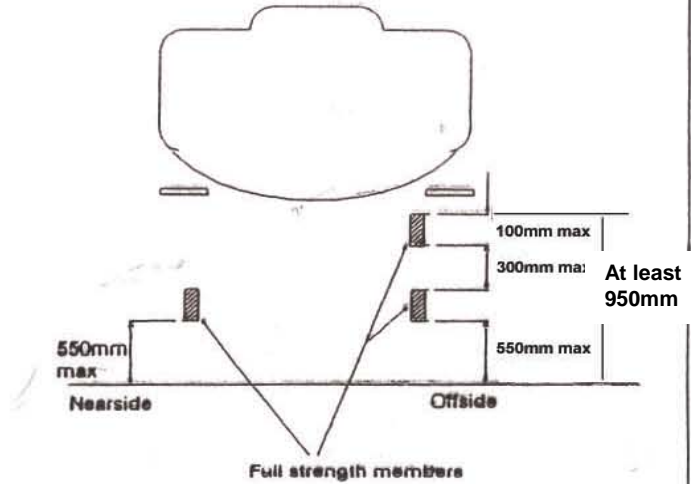
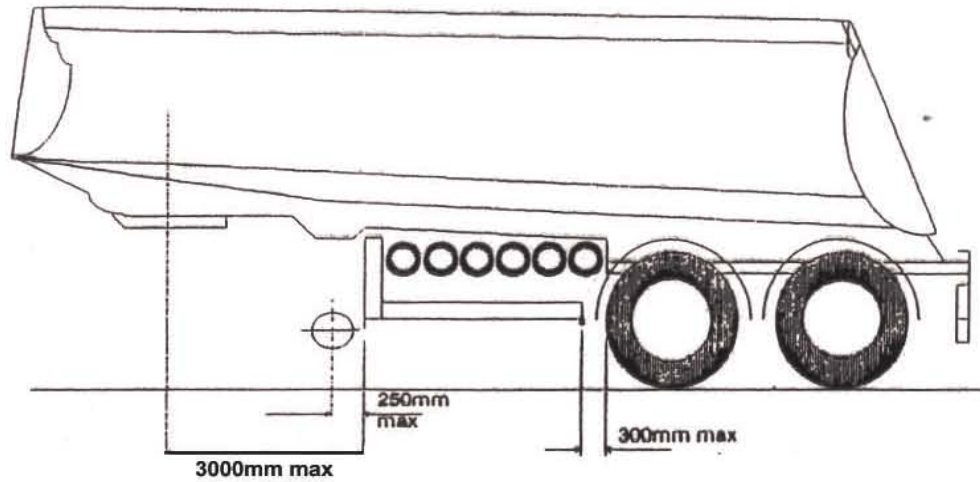

Sideguards must be no more than 150mm in from the outermost plane of the vehicle (maximum width). The last 250mm of the guard at the rear must be no more than 30mm from the tangential plane of the rear tyres.

09 Sideguards, Rear Under-Run Devices & Bumper Bars

Method of Inspection	Reason for Failure
<p>Check Sideguards for:</p> <ol style="list-style-type: none"> 1. fitment to a vehicle required to have them. 2. Check a sideguard or bracket for: <ol style="list-style-type: none"> a. security. b. condition. c. surfaces which are smooth. d. external edges that are radiused. e. correct dimensions visually. f. being continuous along the vehicle length in other than accepted circumstances (See application) . g. overall width. h. the height from the ground to the lowest edge of the guard. (Not applicable to semi trailers attached to a tractor unit where the lower edge is not horizontal with the ground, there is no requirement to separate the trailer from the tractor). 	<p>Sideguards:</p> <ol style="list-style-type: none"> 1. not fitted to a vehicle required to have them fitted. 2. A sideguard or bracket: <ol style="list-style-type: none"> a. insecure. b. cracked, fractured, corroded or damaged so that its effectiveness is reduced. c. with exposed surfaces which are not smooth (e.g. projecting brackets, jagged edges, bolt heads that are not dome shaped). d. with external edges that are not radiused. e. with incorrect dimensions. f. that is not continuous along the vehicle length in other than accepted circumstances. g. that increases the overall width of the vehicle. h. with more than 550mm height from the ground to the lowest edge of the guard. (vehicle unladen or semi-trailer load platform horizontal).

09 Sideguards, Rear Under-Run Devices & Bumper Bars

Method of Inspection	Reason for Failure
<p>Check Rear Under-Run Devices are:</p> <p>3. fitted to a vehicle required to have one.</p> <p>4. Check a Rear Under-Run device for:</p> <ul style="list-style-type: none"> a. security. b. condition. c. jagged edges. d. being no more than 550mm from the ground unladen. e. not extending beyond the outer edge of the outermost rear tyre. f. the outer end of the device being no more than 100mm inboard of the outer edge of the outermost rear tyre (or not more than 300mm inboard where a demountable body is fitted). g. not extending beyond the outermost width of the vehicle which is fitted with a tail lift. h. complete. <p>5. Check a bumper bar or bracket for:</p> <ul style="list-style-type: none"> a. security. b. jagged or projecting edges. 	<p>Rear Under-Run Device:</p> <p>3. not fitted to a vehicle required to have one fitted.</p> <p>4. A Rear Under-Run device:</p> <ul style="list-style-type: none"> a. insecure. b. cracked, fractured, corroded or damaged so that its effectiveness is reduced. c. that has a jagged edge. d. with more than 550mm ground clearance (unladen). e. which extends beyond the outer edge of the outermost rear tyre (see note in application). f. with the outer end of the device more than 100mm inboard of the outer edge of the outermost rear tyre (or more than 300mm inboard where a demountable body is fitted). g. extends beyond the outermost width of the vehicle which is fitted with a tail lift. h. incomplete. <p>5. A bumper bar or bracket which is:</p> <ul style="list-style-type: none"> a. insecure. b. has a jagged or projecting edge likely to cause injury.

Heavy Goods Vehicle Inspection Manual

10 Spare Wheel & Carrier	
Application	
This inspection applies to all vehicles and trailers fitted with a spare wheel or carrier.	
Method of Inspection	Reason for Failure
1. Check the spare wheel and carrier are secure, free from damage, and are correctly positioned.	1. A spare wheel or carrier so insecure, damaged or positioned so that either is likely to fall from the vehicle.

**11 Vehicle to Trailer Coupling
Application**

This examination applies to all vehicles fitted with a trailer coupling (at the front or at the rear) and to all trailers. This inspection also covers fifth wheel couplings mounted on converter dollies.

If the vehicle has a coupled trailer it must not be uncoupled.

To check for relative movement between the tractor and trailer apply the trailer brakes and ask the driver to lightly shunt the tractor back and forth.

When assessing wear/lift between bracket/bush or pin/bush consideration should be given to those bushes which have been designed to provide a cushioning effect in order to relieve shock loadings. The load when the bush is fully compressed is taken from the main plate directly onto the mounting bracket and therefore some degree of controlled lift, up to 8mm in some units is acceptable in the trunnion pin and bush (Up to 12mm lateral movement is acceptable in some cases in fifth wheel couplings, lateral movement of draw-bar turntable top plate movement relative to the lower plate should not exceed 10mm).

Wear should be considered excessive if a drawing hitch, bar, hook, eye, ball or ball socket has the metal reduced to $\frac{3}{4}$ of its original thickness.

If the inspection of the fifth wheel jaws is carried out without a trailer attached, then wear on the jaws in excess of 6mm would be considered a Reason for Failure.

Many manufacturers determine gross train weights by the number and size of bolts fitted to fifth wheel bed plates and sub-frames, these bolts are therefore considered to be mandatory.

Examples of a secondary locking devices are:

- a. A dog clip and chain.
- b. Spring loaded pin between the operating handle and the body of the 5th wheel housing.
- c. Lever dropped behind the operating handle.

An optional third 5th wheel locking device such as a dog clip with a chain or wire from the secondary clip to a hole in the handle could be fitted. The chain or wire may only be there to assist the operator to unlock the secondary device. The absence of a chain/wire is not a RfF if its only purpose is to prevent loss of the dog clip.

11 Vehicle to Trailer Coupling

Method of Inspection	Reason for Failure
<p>1. Check the drawing hitch, bar, hook, eye, ball or ball, socket; or a fifth wheel king pin and its mounting or a turntable for:</p> <ul style="list-style-type: none"> a. wear. b. distortion. c. cracking. d. security. e. movement. f. clearance between upper and lower plates of a turntable. g. presence and operation of locking device. <p>2. Check the Fifth Wheel Coupling for:</p> <ul style="list-style-type: none"> a. security between the fifth wheel and its mounting sub-frame and or chassis. b. all mandatory bolts are secure and present. c. wear and adjustment of the jaws. d. the safety locking device being operative. e. wear in an articulating bracket or pivot and its security. f. cracks in a load bearing member. g. security and wear of any operating members to the extent the coupling is safe. 	<p>1. A drawing hitch, bar, hook, eye, ball or ball socket; or a fifth wheel king pin and its mounting or a turntable which:</p> <ul style="list-style-type: none"> a. is excessively worn. b. is seriously deformed impairing its effectiveness and or weakens the component. *c. is cracked. d. is insecure. *e. has excessive movement between the vehicle and trailer. f. a turntable which has no clearance between mating surfaces, i.e. evidence of contact between the surfaces. g. has a missing, damaged, seized and or inadequate safety or locking device. <p>2. A Fifth Wheel Coupling with:</p> <ul style="list-style-type: none"> a. insecurity between the fifth wheel and its mounting sub-frame and or chassis. b. a mandatory bolt loose or missing. c. jaws so worn or out of adjustment that the trailer kingpin might not be securely held. d. a safety locking device is inoperative. e. an articulating bracket or pivot excessively worn or insecure. f. any crack in a load bearing member. g. an operating member insecure or worn to such an extent the coupling is unsafe.

12 Trailer Parking and Emergency Brakes and Air Line Connections

Application

Parking and Emergency Brakes

This inspection applies to all trailers.

Air Line Connections

This inspection applies to **all trailers of whatever age** and to **drawing vehicles first used from 1 April 1989**.

Emergency Brake and Air Line Connections:

- Ensure that the air reservoirs on the drawing vehicle are fully charged.
- With the vehicle parking brake on and the trailer parking brake **off**, ask the driver to disconnect the service (yellow) and emergency (red) brake lines.
- Check, on vehicles and trailers fitted with "C" type couplings, that the coupling in the service (yellow) line - either fitted to the trailer or in the line itself - is fitted with an operating adaptor which can open the self sealing coupling in the connector from the drawing vehicle.
- Check that the operating adaptor lifts the indicator on the test coupling by the correct amount. The waisted portion (coloured section) of the indicator must be exposed, but no more than this. This does not include additional couplings which may be used on trailers such as extendable types.
- Check that any brake line on the drawing vehicle is not fitted with a manual shut-off tap. Additional taps fitted to extendable trailers are not included in this inspection.

The driver must be instructed to reconnect all couplings before the vehicle is moved

When presented, the tractor unit must be compatible with the trailer and have a warning lamp to indicate that trailer ABS is working (This may be a combined ABS/EBS warning light).

If presented with a compatible EBS tractor unit, if the red line is dropped, the brakes may not come on. To apply the brakes disconnect the ISO 7638 electrical connection. Ensure that the handbrake is applied on the tractor unit before disconnecting the red line and that safe working practices are followed.

Provided self sealing couplings are used on the tractor couplings it does not matter whether the air adaptor couplings are the conventional way or reversed.

Some park brake controls also deplete the air suspension systems when the red air line is removed, this is acceptable provided it does not drain the air brake reservoir. If it does the vehicle must fail under RfF 5a of section 59.

12 Trailer Parking and Emergency Brakes and Air Line Connections	
Method of Inspection	Reason for Failure
<p>1. Check trailer parking brake:</p> <ul style="list-style-type: none"> a. operates on at least two road wheels. b. can be securely set. c. mechanism is secure, is not cracked, excessively worn or badly corroded. d. when fully applied, check that the mechanism is not at the end of its working travel and there is no fouling of adjacent parts. <p>2. Check the Trailer emergency brake to ensure that the trailer brakes are automatically applied when the emergency line is disconnected.</p> <p>3. Check operating adaptor, to open self sealing coupling:</p> <ul style="list-style-type: none"> a. presence in service (yellow) line. b. produces correct amount of lift. <p>4. Check that any brake line on the drawing vehicle is not fitted with a manual shut-off tap.</p>	<p>1. Trailer parking brake:</p> <ul style="list-style-type: none"> **a does not operate on at least two wheels. **b cannot be securely set. c mechanism insecure, cracked, excessively worn or badly corroded. d when fully applied the mechanism is at the end of its working travel or it is fouling adjacent parts of the vehicle. <p>**2. Trailer emergency brake not applied automatically when the emergency (red) brake line is disconnected (see application note).</p> <p>3. Operating adaptor, to open self sealing coupling:</p> <ul style="list-style-type: none"> a. not fitted in service (yellow) line. *b. produces incorrect amount of lift. <p>**4. An airline fitted with a manual shut off tap.</p>

13 Trailer Landing Legs	
Application	
<p>This inspection applies to all trailers fitted with landing legs.</p> <p>If any leg or part of a leg is missing it is not a Reason for Failure.</p>	
Method of Inspection	Reason for Failure
<p>1. Check for security of the landing leg and any component part.</p>	<p>1. A landing leg or any component part so insecure that it is likely to fall from the vehicle.</p>

14 Spray Suppression, Wings and Wheel Arches

Application

Wings and Wheel Arches

This inspection applies to all vehicles and trailers.

Road wheels must have associated with them equipment or part of the body which, as far as is practicable, catches mud or water thrown up by the wheels as they rotate. Check that the wing covers the whole width of the tyre especially where wide “Super Single” tyres are fitted to the front axle.

A trailer used for or in connection with the carriage of round timber does not require the fitment of wings.

With regard to the requirements for wings and wheel arches, a vehicle may be passed without wings when a semi-trailer/body/container is carried which fulfils the requirements of a wing i.e. a vehicle presented for annual test towing a trailer and the wing tops are not fitted on the vehicle due to the trailer being very close to the tyres. This is not a reason for failure for wings or spray suppression providing the rotation of the wheels does not permit mud or water to be thrown directly on the road surface.

Mudflaps

If a mudflap is an extension to a wing or similar fitting, a missing or damaged mud flap **is not** a Reason for Failure, unless the vehicle is required to have one to comply with spray suppression requirements.

Where a mudflap is fitted in place of a wing, i.e. it serves the purpose of a wing (as on some semi-trailers) it must be treated as a wing and be securely fixed to prevent excessive movement.

Spray Suppression

This inspection applies to those vehicles shown below unless listed as exempt.

Motor Vehicles	Trailers
a. exceeding 12 tonnes design GVW, and first used from 1 April 1986.	a. exceeding 3.5 tonnes design GVW and manufactured from 1 May 1985.
	b. exceeding 16 tonnes design GVW with 2 or more axles, whenever manufactured.

14 Spray Suppression, Wings and Wheel Arches

Application

Spray Suppression Exempted Vehicles:

- Motor vehicle where the driving power of its engine is, or can by use of its controls be, transmitted to all the wheels on at least one front axle and on at least one rear axle.
- Vehicles with a high ground clearance (400mm minimum).
- A vehicle specially designed and not merely adapted for the carriage and mixing of concrete.
- A vehicle or trailer constructed so that it can be unloaded by part of the vehicle being tipped sideways or rearwards.
- A vehicle or trailer designed solely for use in connection with street cleaning, the collection/disposal of refuse or the contents of gullies/cesspools (skip carrying vehicles are classed as refuse vehicles and as such are exempt).
- A trailer specially designed and constructed, not merely adapted, to carry round timber, beams or girders being items of exceptional length.
- A **rigid motor vehicle** or **trailer** designed for and constructed for the special purpose of carrying long (but not exceptionally long) timbers from an off road location in a forest.

To fulfil this definition the vehicle must meet the following criteria:

- a. It must be of skeletal construction.
- b. It must have a minimum of two upright side supports (sidebolsters) fitted to each side of the vehicle.
- c. It must not be fitted with a load platform, other than chassis rails, cross bearers and the minimum amount of flooring necessary to protect wiring or brake line components.

It is permissible for the vehicle to be fitted with the following:

- Loading equipment e.g. a Hiab crane or similar device.
- Cross bearers that do not have upright side supports.

This list is not exhaustive but covers the vehicles likely to be encountered within the testing scheme.

Tractor units drawing exempt trailers are not themselves exempt.

14 Spray Suppression, Wings and Wheel Arches
Application

The test on spray suppression includes only a basic visual check for general compliance and it will normally not be necessary to take measurements. A simple gauge has been issued to assist staff in cases of doubt on certain key dimensions.

Tractor units and Skeletal Vehicles/ Trailers must be fitted with complete wings to fulfil the spray suppression requirements.

Lifting axles are not exempt from the requirements and are therefore treated as a normal axle.

Type Approved Vehicles exempt from spray suppression

If the presenter claims that the vehicle or trailer is type approved with an exemption from spray suppression (this will most often be on an imported trailer) which comply with the requirements of the EC directive, the presenter should be asked to provide documentary evidence.

Vehicles/Trailers with Demountable Bodies

1. These are **not** exempt from the requirements. In some cases it will therefore be necessary for the body to be in place since the mudwing or valance is often attached.
2. Some **demountable bodies** can be unloaded by tipping, using a conventional ram attached to the vehicle. These are classed as tippers and are therefore exempt from the spray suppression requirements.

The 200mm flap height can be increased to 300mm for:

- any vehicle or trailer equipped with road friendly suspension.
- the rear most flap height only, for trailers claimed to be used on **Ro-Ro ferry operations**.
- any axle where the radial dimension to the lower edge of the valancing, or wheel guard, is not greater than the radius of the tyre.

Deliberate modifications for attachment points for rope hooks are not acceptable and should fail as incomplete.

14 Spray Suppression, Wings and Wheel Arches Application

The **width** of the flap should cover the full breadth of the tyre(s).

Vehicles/trailers first used from 1 April 2000 must have spray suppression that covers the **whole width** of the tyres. It is acceptable for vehicles/trailers before 1 April 2000 that the spray suppression will only cover the **tyre tread breadth**.

Earlier Mercedes Actros model ranges had gaps between the spray suppression flap top edge and the mud wing bottom edge (the edges were not parallel with each other); these do not comply with the spray suppression requirements and should be failed. The later models do comply because the gap is at the same level as the mud wing thus containing the spray thrown up by the rotation of the wheel (see below).

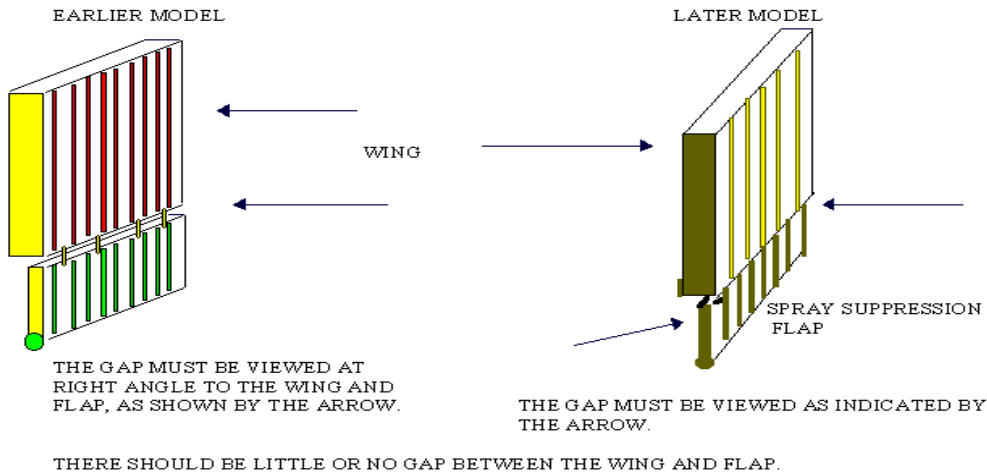

On trailers where all the wheels steer, it may appear to be incompatible to fit spray suppression, these vehicles are not exempt but spray suppression only needs fitting as far as it is practicable.

14 Spray Suppression, Wings and Wheel Arches
Application

Conventional Mudwing Types of Wheel Guards

Single Axle Arrangements or Multi-axle arrangements where distance between wheels is greater than 300mm.

The lower edge of the outer valance shall not exceed 1.5 x tyre radius on steerable wheels or 1.25 x tyre radius on non-steerable wheels at points A, B and C.

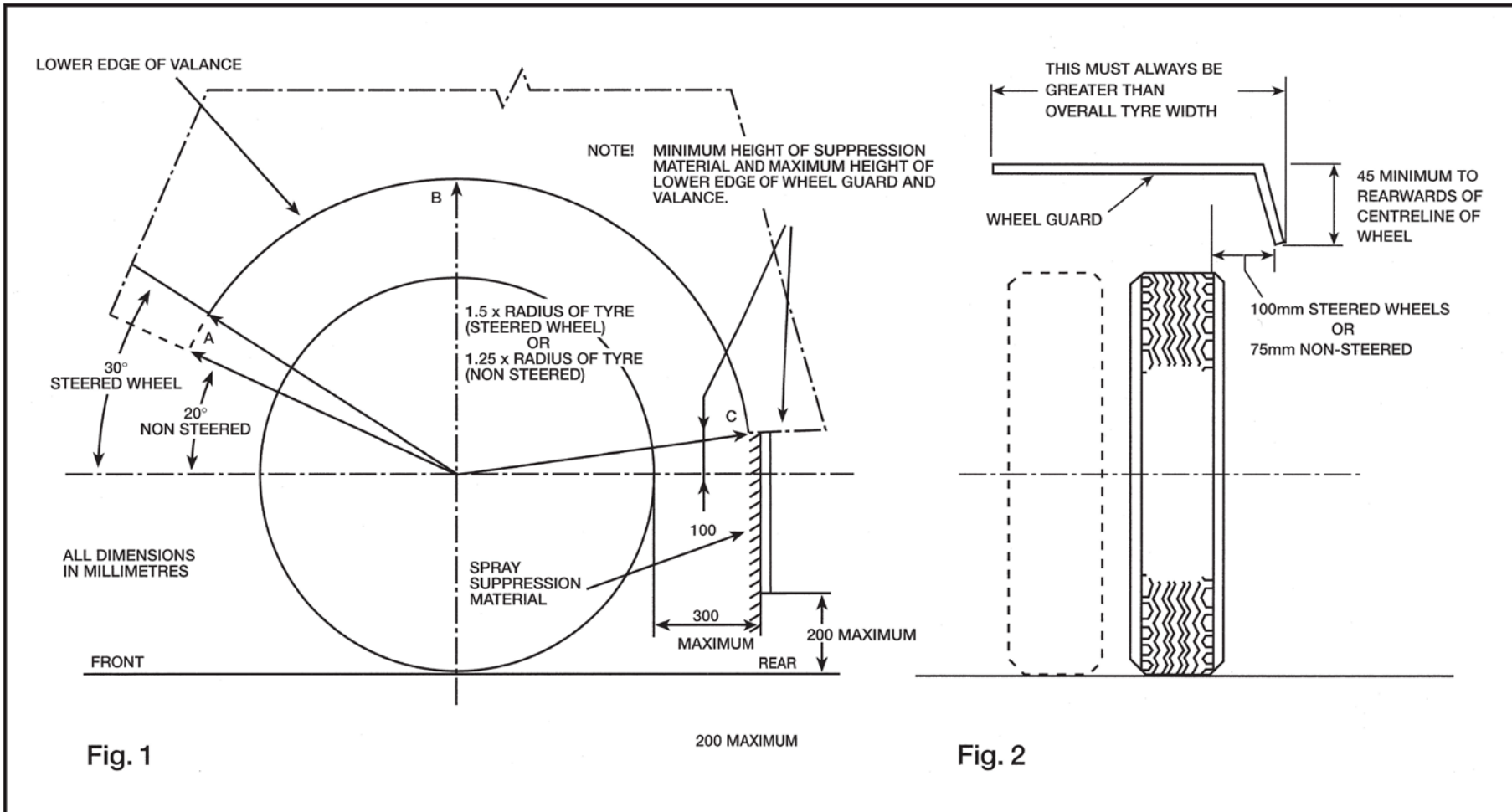

14 Spray Suppression, Wings and Wheel Arches
Application

Wheel Flaps

Wheel flaps must be fitted behind each wheel and should cover the full breadth of the tyre(s) and be mounted to the wing without gaps that would permit the exit of spray.

Suppression material must be fitted to:

- a. the forward face of the flap and
- b. to the forward face of that part of the wing (guard) if it reaches below a line 100mm above a line projected from the wheel centre line.

Wheel Guards

Where the wheel guard consists of several components there should be no gaps between or within individual parts when assembled that will permit the exit of spray when the vehicle is in motion.

**14 Spray Suppression, Wings and Wheel Arches
Application**

Conventional Mudwing Types of Wheel Guards

Multi-axle arrangements where distance between wheels is 300mm or less

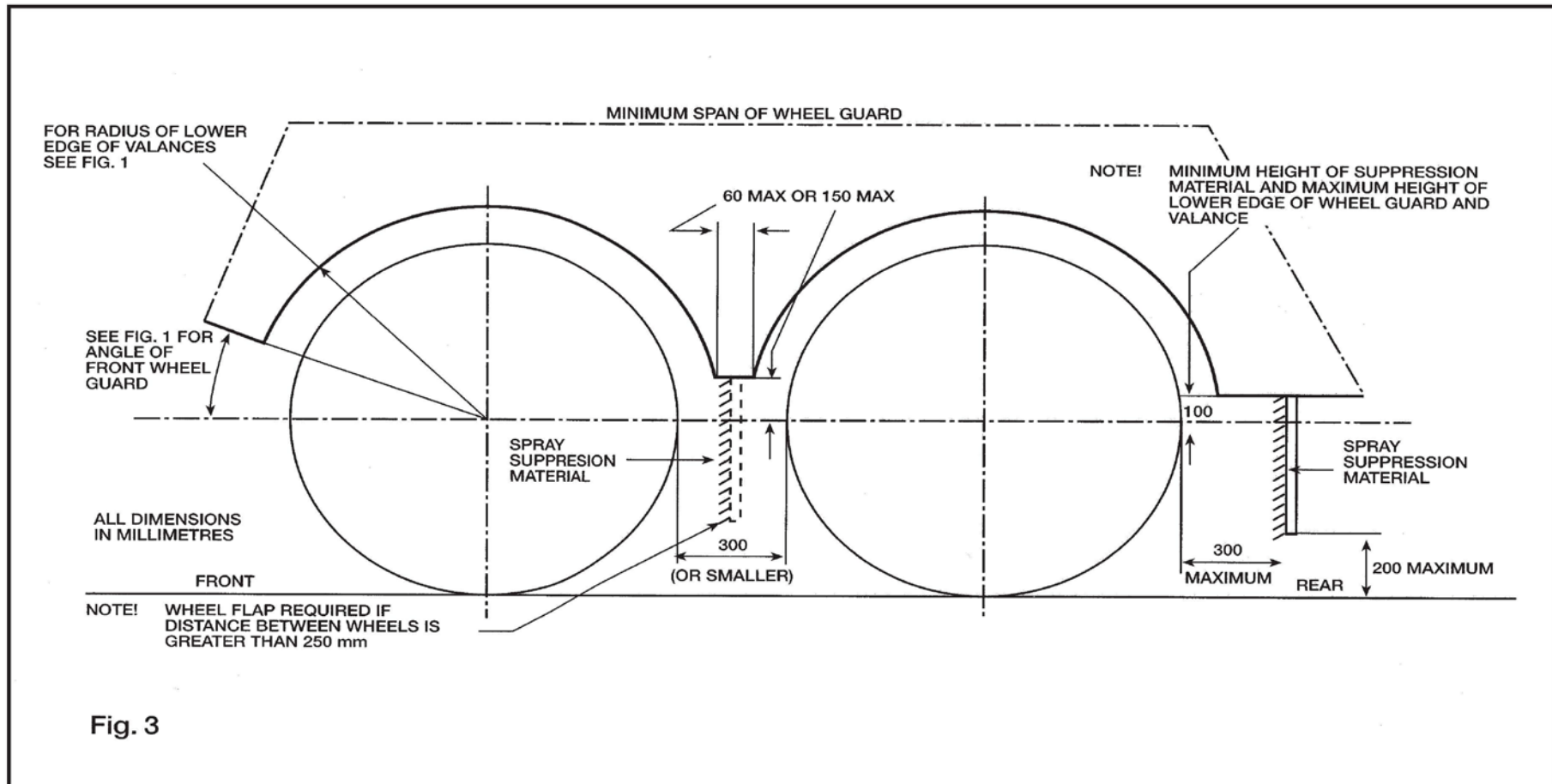

Fig. 3

The lower edge of the outer valance shall not exceed 1.5 x tyre radius on steerable wheels or 1.25 x tyre radius on non-steerable wheels at points A,B and C as in the single axle diagram.

14 Spray Suppression, Wings and Wheel Arches

Application

Wheel Flaps

Wheel flaps should cover the full breadth of the tyre(s) and be mounted to the wing without gaps that would permit the exit of spray.

Wheel flaps are required behind each wheel where the distance between tyres on a group of multiple axles is 250mm or more. Up to 290mm can be accepted where it is clear that the limit of 249mm is exceeded only by tyre wear.

Where the distance between tyres on a group of axles is less than 250mm, wheel flaps are only required on the rearmost axle of each group.

Suppression material must be fitted to:

- The forward face of the flap and
- The forward face of that part of the wing (guard) if it reaches below a line 100mm above a line projected from the wheel centre line.

Wheel Guards

Where the wheel guard consists of several components there should be no gaps between or within individual parts when assembled that will permit the exit of spray when the vehicle is in motion.

**14 Spray Suppression, Wings and Wheel Arches
Application**

Single or Multi-axle arrangements using Half Wing and Valances.

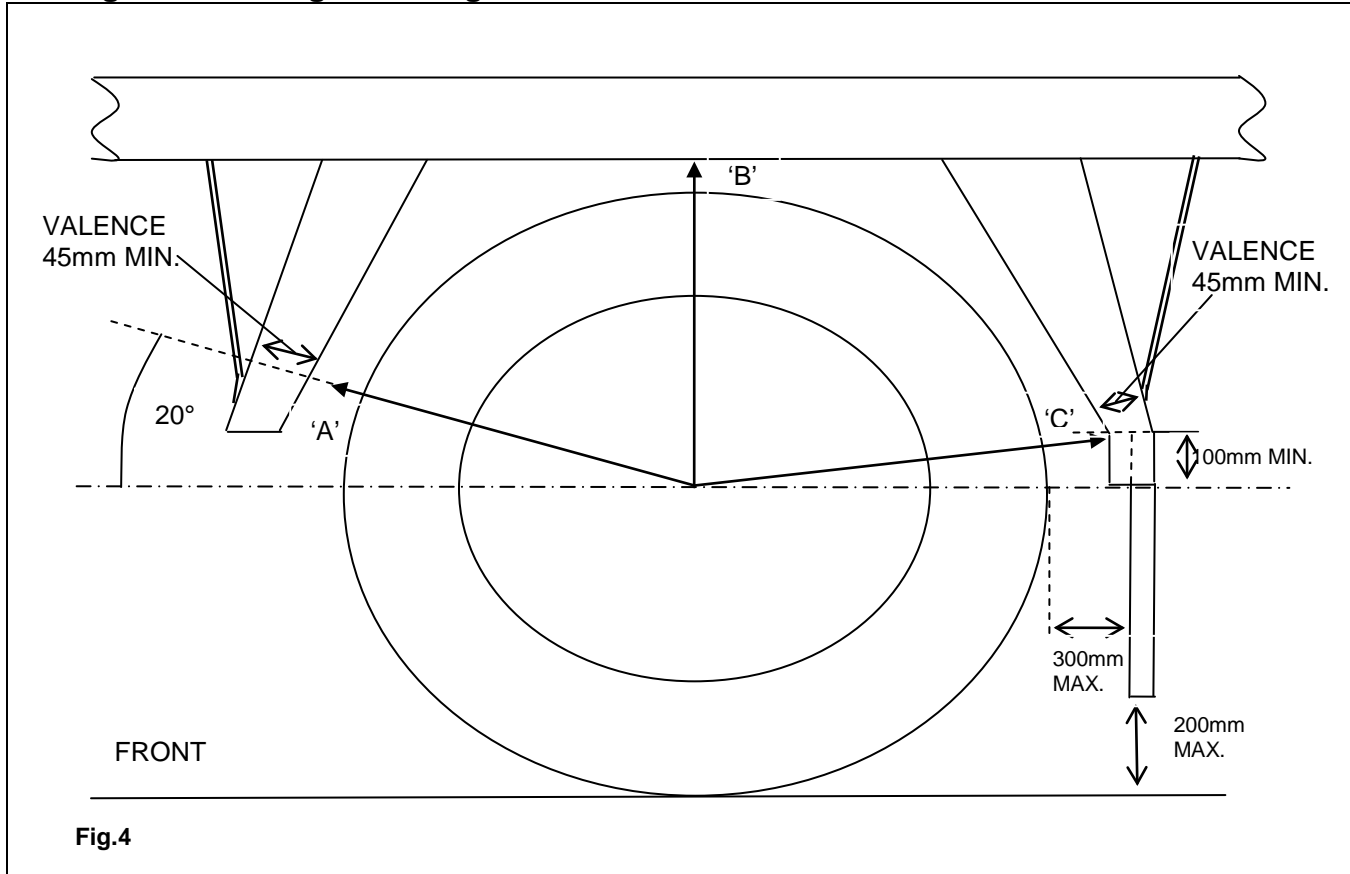

The lower edge of the outer valance shall not exceed 1.5 x tyre radius on steerable wheels or 1.25 x tyre radius on non-steerable wheels at points A, B and C.

14 Spray Suppression, Wings and Wheel Arches

Application

Wheel Flaps

Wheel flaps must be fitted behind each wheel and should cover the full breadth of the tyre(s) and be mounted to the wing without gaps that would permit the exit of spray.

Where the distance between tyres on a group of axles is less than 250mm, wheel flaps are only required on the rearmost axle of each group. Up to 290mm can be accepted if it is clear that the limit of 249mm is exceeded only by tyre wear.

Suppression material must be fitted to:

- The forward face of the flap and
- to the forward face of that part of the wing (guard) if it reaches below a line 100mm above a line projected from the wheel centre line.

Wheel Guards

Where the wheel guard consists of several components there should be no gaps between or within individual parts when assembled that will permit the exit of spray when the vehicle is in motion.

Note that in the case of steerable wheels the 20 Deg. angle is increased to 30 Deg.

The breadth of the wing valance at points A and C must be at least 45mm as must be the body valance depth at point B.

**14 Spray Suppression, Wings and Wheel Arches
Application**

Flap and Valance System for Non-Steered Axles

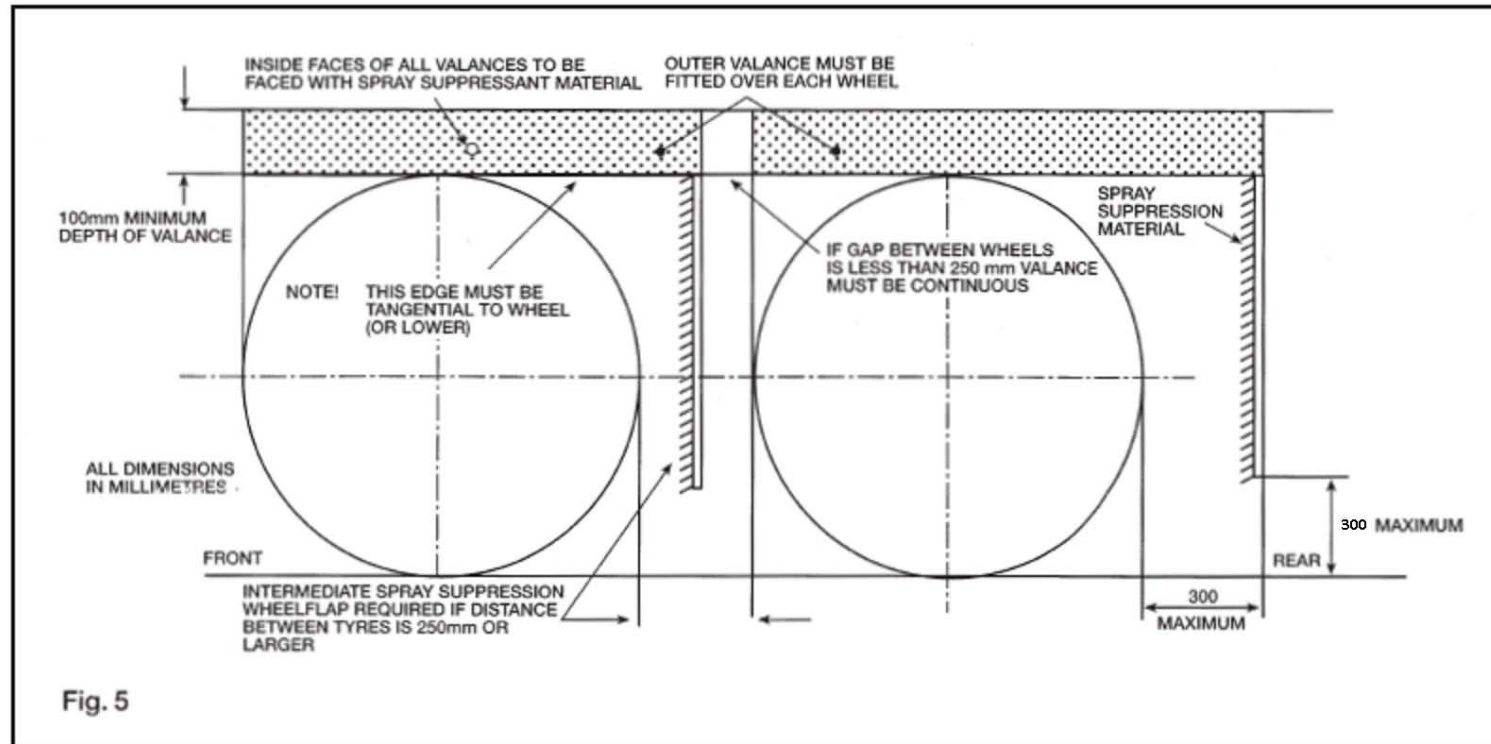

The valance should cover the area extending from the underside of the body to at least a line formed by the tangent to the top of the tyres and between the outer edge of the wheel flap, with which it should form a seal and the vertical plane formed by the tangent at the front of the tyre. An outer valance must be fitted over each wheel.

The whole inner face of the outer valance, the depth of which should not be less than 100mm, must be fitted with a suppression material.

**14 Spray Suppression, Wings and Wheel Arches
Application**

Wheel Flaps

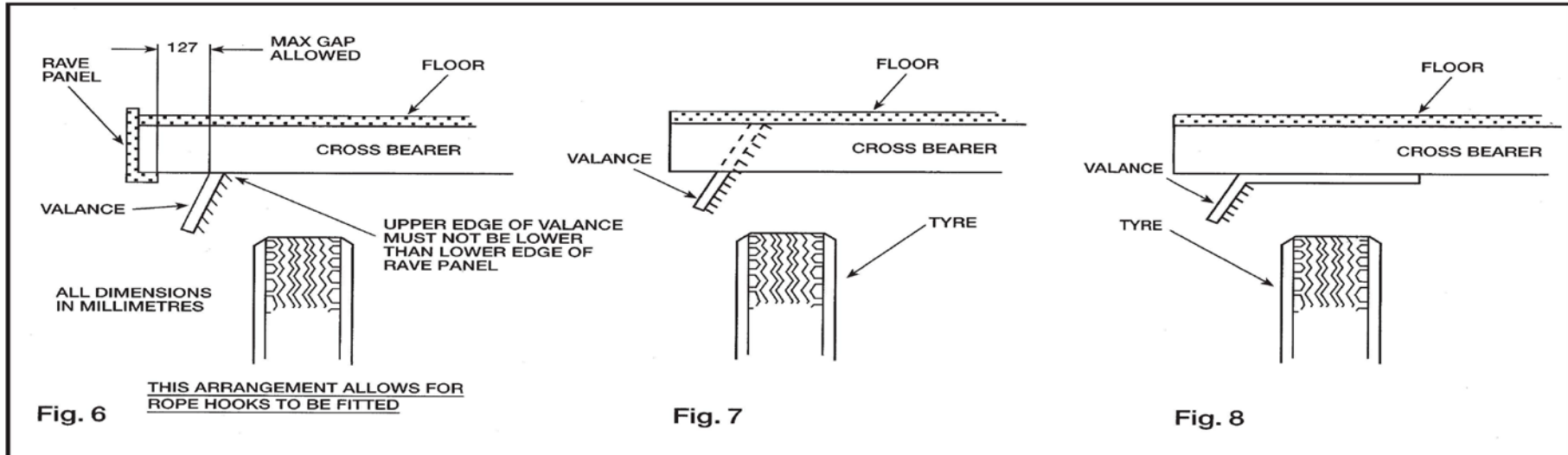

Wheel flaps should extend to the underside of the vehicle structure. The whole of the forward facing part of the wheel flap should be fitted with a suppression material or device. There should be no gaps that would permit the exit of spray.

Suppression material must be fitted to

- the forward face of the flap and
- to the forward face of that part of the wing (guard) if it reaches below a line 100mm above a line projected from the wheel centre line.

14 Spray Suppression, Wings and Wheel Arches
Application

Spray Suppression Systems with Air/Water Separation Devices on the Lower Edge of Valances ("Cats Whiskers" or "Netlon")
Single axle and Multi-axle arrangements.

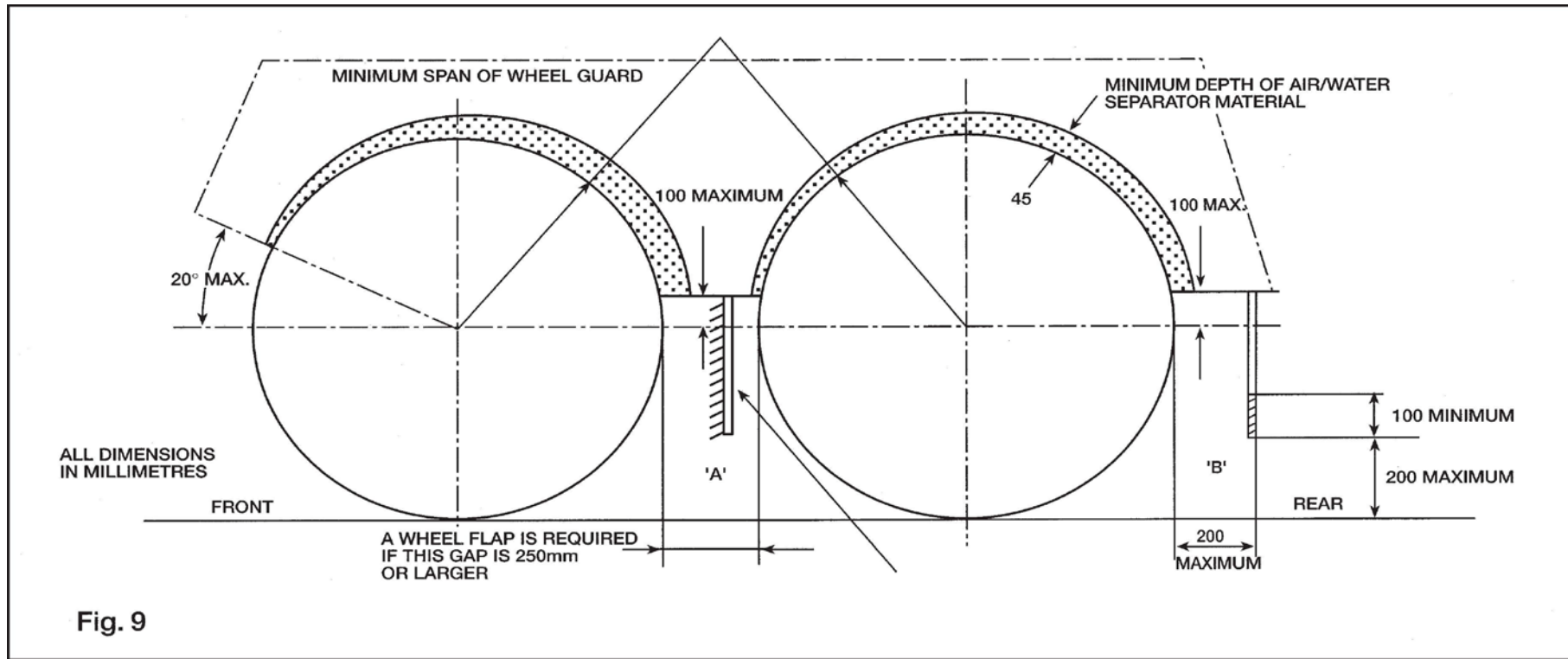

The **Wheel Guards** should comply in all respects with the requirements given for the conventional mudwing system.

Valances should have air/water separating material on their lower edges to a depth of not less than 45mm to the rear of the vertical centre line of the wheel. This depth may be progressively reduced forward of the centre line.

There should be no openings in outer valances or between outer valances or wheel guards that would allow spray to be emitted.

For non-steered wheels, the radius of the lower edge of the valance, including the air/water separating device, must not be greater than the radius of the tyre. With steered wheels however the radius of the lower edge can be up to approximately 25mm larger than the radius of the tyre.

14 Spray Suppression, Wings and Wheel Arches
Application

Wheel flaps must be either

Fitted with suppression material to:

- the forward face of the flap and
- to the forward face of that part of the wing (guard) if it reaches below a line 100mm above a line projected from the wheel centre line (as at "A" in the diagram above).

or

- the lower part should consist of an air/water separator, the length of which shall be at least 100mm. The maximum height of the bottom edge should not exceed 200mm and the maximum distance behind the tyre is reduced to 200mm (as at "B" in the diagram above).

Where the distance between tyres on a group of axles is less than 250mm, wheel flaps are only required on the rearmost axle of each group. Up to 290mm can be accepted if it is clear that the limit of 249mm is exceeded only by tyre wear.

14 Spray Suppression, Wings and Wheel Arches

Method of Inspection	Reason for Failure
<p>Wings and Wheel Arches. 1. Check all Wings or Wheel Arches for:</p> <ul style="list-style-type: none"> a. presence and security or, in the case of a mud flap fitted as a wing, it is restrained or constructed to stop wind lift. b. corrosion and distortion. c. sharp edges that are likely to cause injury. d. rubbing on a tyre. e. covering the whole width of a tyre when the wheel is in the straight ahead position. <p>Spray Suppression. 2. Check Spray Suppression for:</p> <ul style="list-style-type: none"> a. presence where required. b. completeness and free from serious defects. c. dimensions complying with requirements. d. wheel flap(s) being restrained or stiff enough to stop excessive movement or wind lift in normal use. e. being clogged with mud or debris. 	<p>Wings and Wheel Arches. 1. A Wing or Wheel Arch:</p> <ul style="list-style-type: none"> a. missing or so insecure that it can fall off or rub on the tyre, or, in the case of a mud flap fitted as a wing, it is not restrained or constructed to stop wind lift. b. so badly corroded or distorted to stop it acting as an adequate shield. c. that has sharp edges that are likely to cause injury. d. which is rubbing on a tyre. e. which does not cover the whole width of a tyre when the wheel is in the straight ahead position. <p>Spray Suppression. 2. Spray Suppression:</p> <ul style="list-style-type: none"> a. insecure or not fitted where required. b. incomplete or seriously defective. c. dimensions do not comply with requirements. d. with a wheel flap not restrained or stiff enough to stop excessive movement or wind lift in normal use. e. with more than 25% of the minimum required wheel flap or spray suppression material area clogged with mud or debris.

**15 Cab Security
Application**

This inspection applies to all vehicles.

All means of securing the cab are to be inspected where practical.

Movement which is designed into mountings should not be confused with excessive wear.

Cab security inspection applies to the primary and secondary locking devices for tilt cabs.

The inspection does not cover air leaks from cab air suspension unless it affects the brakes. This would be an RfF within the appropriate brake section.

Method of Inspection	Reason for Failure
<p>1.</p> <ul style="list-style-type: none"> a. Check for security and condition by pushing and rocking the cab by hand where practical. b. On tilt cabs examine the retention and/or locking devices for damage and security. c. Check the front hinge pins and/or brackets for wear such that safe control of the vehicle is not affected. d. Check there is no excessive corrosion or damage to a load bearing member which seriously reduces its strength near the cab mountings. e. Visually check wind deflectors and other cab mounted accessories for security. 	<p>1.</p> <ul style="list-style-type: none"> ** a. Any insecurity that is likely to affect the drivers control of the vehicle. b. A retention and/or locking device on a tilt cab missing or defective. c. Wear of front hinge pins and/or brackets such that safe control of the vehicle may be impaired. d. Excessive corrosion or damage to a load bearing member which seriously reduces its strength near the cab mountings. e. A wind deflector or other accessory so obviously insecure that it is likely to become detached.

16 Cab Doors
Application

This application applies to all vehicles

Only one operational door is required. On security vehicles this door may be fitted so that it does not open directly into the cab. Other doors which have deliberately been made inoperative should be considered part of the cab and not a door. A door with one handle missing should not be failed, if the door can be opened from inside using the remaining handle.

Method of Inspection	Reason for Failure
<p>1. Check that a door:</p> <ul style="list-style-type: none"> a. is fitted. b. can be opened. c. is not so worn or damaged that the door is very difficult to open or close. d. opens and closes and check that they will not open inadvertently. 	<p>1. A Door which:</p> <ul style="list-style-type: none"> a. is missing. b. cannot be opened. c. is worn or damaged so that it is very difficult to open or close. d. will not remain closed or is likely to fly open inadvertently (If a door fitted with a two position catch will only engage in the first or semi-shut position, this will be regarded as a reason for failure).

Heavy Goods Vehicle Inspection Manual

17 Cab Floor and Steps	
Application	
This inspection applies to all vehicles.	
Method of Inspection	Reason for Failure
<ol style="list-style-type: none">1. Examine the condition of the cab floor and internal wheel arches.2. Examine the condition and security of the steps to cab.	<ol style="list-style-type: none">1. A cab floor or internal wheel arch which is so badly deteriorated or insecure that it would impair the drivers control.2. Any step or step ring so insecure or dangerous that it is likely to cause injury.

18 Seats	
Application	
<p>This inspection applies to all vehicles.</p> <p>When checking the driver's seat adjustment it is not necessary to check that the seat can be secured in all possible positions.</p> <p>In the case of electrically adjusted seats, it is not necessary to check any 'memory position' function.</p>	
Method of Inspection	Reason for Failure
<ol style="list-style-type: none"> 1. Check the driver's seat for condition and security. 2. Check that the driver's seat position can be adjusted forwards and backwards and secured in the selected positions. 3. Check all passenger seats for security and that the back rest can be secured in the upright position. 	<ol style="list-style-type: none"> *1. A driver's seat so insecure or in such a condition that it could cause the driver to lose control of the vehicle. 2. The driver's seat fore and aft adjustment mechanism not functioning as intended. 3. A passenger seat insecure or a back rest that cannot be secured in the upright position.

19 Security of Body, Containers and Crane Support Legs

Application

Security of Body

This inspection applies to all vehicles and trailers fitted with a body.

The inspection covers:

- all fixings (e.g. brackets) securing the body to the chassis or to a sub-frame or supporting members.
- fastenings e.g. securing bolts, rivets or welds for the fixings.
- structural (stressed) panels.

Defective fastenings do not necessarily mean that the body is insecure. The whole structure must be assessed and a failure will only be justified where sufficient bolts, rivets and welds etc are loose or defective to allow the body to move enough to cause a hazard for other road users.

Some designs of body mounting allow a limited amount of flexing between the body and chassis. This must not be confused with insecurity. On body mountings with tie-bars the securing nut on the tie-bar is correctly secured with a relatively low torque setting and this should not be mistaken for looseness.

Coach bolt failure due to corrosion may not be obvious, as the failed section may be in a position where it cannot be seen. Care should be taken to check that there is no sign of an abnormal movement of the structure which would indicate coach bolt failure.

Security of Containers

This inspection applies to all vehicles and trailers constructed or adapted to carry removable shipping containers, whether a container is mounted or not (a dual purpose flatbed trailer from which all twistlocks have been removed is not subject to this inspection).

A secondary locking device is something that stops the primary fastening device coming open accidentally when the vehicle is in motion. To be effective it must give enough resistance to light hand pressure to remain closed.

Support Bolsters and Structures

Presenters should be asked to set any moveable supports or bolsters to a deployed position wherever possible prior to the commencement of the test to assist inspection. The presenter should reset them after the test within British legal length requirements before leaving the test station.

Security of Crane Support Legs

This inspection applies to all vehicles and trailers fitted with supporting legs for loading cranes.

This inspection only applies where retaining devices were originally fitted. A suitable alternative retaining device is acceptable provided the support leg is adequately secured.

19 Security of Body, Containers and Crane Support Legs	
Method of Inspection	Reason for Failure
<p>Security of Body</p> <p>1. Check the body for:</p> <ul style="list-style-type: none"> a. displacement relative to the chassis. b. security. <p>2. Check load bearing members for cracks, corrosion or damage that seriously weaken the body.</p> <p>Security of containers</p> <p>3. Check a container fastening device is:</p> <ul style="list-style-type: none"> a. present. b. secure. c. complete. d. free to move. e. fitted with an effective secondary locking device e.g. screw, detent or chain and clip. f. in such a condition that a container is secured by it. <p>4. Check support bolster or structure for:</p> <ul style="list-style-type: none"> a. security, cracks, corrosion or damage such that a container is supported and secured by it. b. presence of locking pins or other securing method incorporating an effective secondary locking device. <p>Security of crane support legs</p> <p>5. Check Crane Support Legs for:</p> <ul style="list-style-type: none"> a. security. b. retaining device present, secure and in a condition that it would retain the leg. 	<p>Security of Body</p> <p>1. Body:</p> <ul style="list-style-type: none"> a. excessively displaced relative to the chassis. b. insecure. <p>2. A load bearing member so cracked, corroded or damaged that the body is seriously weakened.</p> <p>Security of containers</p> <p>3. A container fastening device:</p> <ul style="list-style-type: none"> a. missing when another of a matched pair is present. b. insecure. c. incomplete. d. seized. e. not fitted with an effective secondary locking device. f. in such a condition that a container is unlikely to be secured by it. <p>4. A support bolster or structure:</p> <ul style="list-style-type: none"> a. insecure, cracked, corroded or damaged such that a container is unlikely to be supported and secured by it. b. not fitted with locking pins or other securing method incorporating an effective secondary locking device. <p>Security of crane support legs</p> <p>5. A Crane Support Legs:</p> <ul style="list-style-type: none"> a. insecure. b. retaining device missing, insecure or in a condition that it would not adequately retain the leg.

20 Condition of Body	
Application	
<p>This inspection applies to all vehicles.</p> <p>Check for defective items which would make the vehicle dangerous to other road users and pedestrians. The cumulative effect of any defects found must be considered or their influence on other items. Superficial damage which does not affect the strength of a component or which does not pose a danger to other road users is not a reason for failure.</p> <p>Check for any insecurity of glass panels or sharp edged glass on vehicles such as mobile shops and ice cream vans.</p>	
Method of Inspection	Reason for Failure
<ol style="list-style-type: none"> 1. Check any headboard, rive, cross or longitudinal member, hinge or retaining device, tipping gear, glass panel or any part of the body designed to carry or contain the load (including the floor and main support pillars) for: <ol style="list-style-type: none"> a. security. b. fractures or cracks. c. distortions, excessive wear or damage. 2. Check for leaks from the load carrying compartment. 	<ol style="list-style-type: none"> 1. Any headboard, rive, cross or longitudinal member, hinge or retaining device, tipping gear, glass panel or any part of the body designed to carry or contain the load (including the floor and main support pillars): <ol style="list-style-type: none"> a. insecure. b. fractured or cracked. c. distorted, excessively worn or damaged. <p>and which in each case would make the vehicle dangerous to other road users and pedestrians.</p> 2. A leak from the load carrying compartment.

22 Mirrors and Indirect Vision Devices

Application

This inspection applies to all vehicles. The number and type of mirrors and or indirect vision devices (excluding periscopes) which have to be fitted are shown below.

DATE OF FIRST USE	REQUIREMENTS
Before 1 April 1985	An exterior mirror on the offside and either an interior mirror (unless this would not give a view to the rear) or an exterior mirror on the nearside
From 1 April 1985	A main exterior mirror on both the offside and nearside
From 1 October 1988 with DGWV greater than 12000 kg	A close proximity mirror on the nearside in addition to those shown above
From 1 October 1988 articulated vehicles with DGWV greater than 12000 kg	A wide angle mirror on the nearside in addition to those shown above
From 1 January 2000 with a DGWV exceeding 3500kg	A main exterior mirror on both the offside and the nearside A wide angle mirror on the passenger side. A close proximity mirror on the passenger side.
From the 26 January 2007 with a DGWV exceeding 7500 kg	A main exterior mirror on both the offside and the nearside. A wide angle mirror on both the offside and the nearside A close proximity mirror on the passenger side. A front mirror

Vehicles registered from 26 January 2007 but before 26 January 2008 in excess of 7500kg may not have a front mirror, these vehicles should be treated as if derogated and therefore pass and advise for this aspect of the inspection.

Any vehicle registered from 26 January 2008 in excess of 7500kg must have a front mirror, provided it can be fitted more than 2m from the ground.

"Indirect vision devices" means devices to observe the traffic area adjacent to the vehicle which cannot be observed by direct vision. These can be conventional mirrors, camera-monitors or other devices (but not a periscope) able to present information about the indirect field of vision to the driver.

"Interior mirror" means a device as defined in the above paragraph, which can be fitted in the passenger compartment of a vehicle.

"Exterior mirror" means a device as defined in the above paragraph, which can be mounted on the external surface of a vehicle.

22 Mirrors and Indirect Vision Devices

Application

For vehicles up to 7500kg if the close-proximity mirror can not be fitted at least 2m from the ground. The vehicle does not require either the wide angle or close-proximity mirrors.

Known makes and models over 3500kg that do not require wide angle or close-proximity mirrors are:

- Iveco Daily
- Johnston Sweepers 5000 series
- Mercedes Chassis Cab Vario with two wheel drive and all Sprinters
- Mitsubishi Fuso Canter
- Nissan Cabstar
- Isuzu N Series this is any Isuzu up to 7500kg
- Renault Mascott and Maxity
- Volkswagen LT and Crafter

There are a minority of vehicles which can achieve the view to the front without a front mirror, if you are in any doubt about the necessity for a front mirror contact TaSS Swansea.

The retro fitting of mirrors from 1 January 2000 does not include the front mirror.

Internal mirrors must be surrounded by protective material, this does not apply to vehicles registered before April 1969.

For the purpose of this inspection on a left hand drive vehicle the nearside is at the right and the offside at the left.

Close proximity and front mirrors must be at least 2m from the ground. If a vehicle is fitted with a low mounted cab so that the mirror cannot be fitted at this height it is exempt from the requirement to fit a close proximity and front mirror. Some Mercedes Unimogs fall into this category or the category of not being a forward control vehicle the U300, U400, U500 & U3000, U4000, U5000, Zetro 1833A and Zetro 2733A are exempt the front mirror but the U20 is not exempt and requires a front mirror.

RfF 2 will not apply to cameras replacing front and or close proximity mirrors fitted less than 2 metres from the ground where the camera is hidden with in the body contour.

A cracked mirror is not a RfF unless the vision is obscured or it is in such a condition that the glass is likely to fall out.

22 Mirrors and Indirect Vision Devices

Method of Inspection	Reason for Failure
<p>Check:</p> <ol style="list-style-type: none"> 1. that the correct number and type(s) of mirror, or other indirect vision device are fitted. 2. that any required close proximity, front mirror or camera for an indirect visual device is fitted at least 2 metres from the ground. 3. that a required mirror or indirect vision device is in such a condition that anyone sitting in the driving seat can see clearly towards the rear, nearside or front where required. 4. mirrors or indirect vision devices and their mounting brackets for security and structure. 5. the internal mirror edge is surrounded by protective material. 	<ol style="list-style-type: none"> 1. Not fitted with the correct number or type(s) of mirror, or other indirect vision device. 2. Part of any required close proximity, front mirror or camera for an indirect visual device is fitted less than 2 metres from the ground. 3. A required mirror or indirect vision device in such a condition that anyone sitting in the driving seat cannot see clearly towards the rear or nearside or front where required. 4. A mirror, indirect vision device or its mounting bracket insecure or structurally deteriorated. 5. An internal mirror edge not surrounded by protective material or with damaged protective material.

**23 Glass and View of the Road
Application**

This inspection applies to all vehicles.

When checking the windscreen refer to the diagram below.

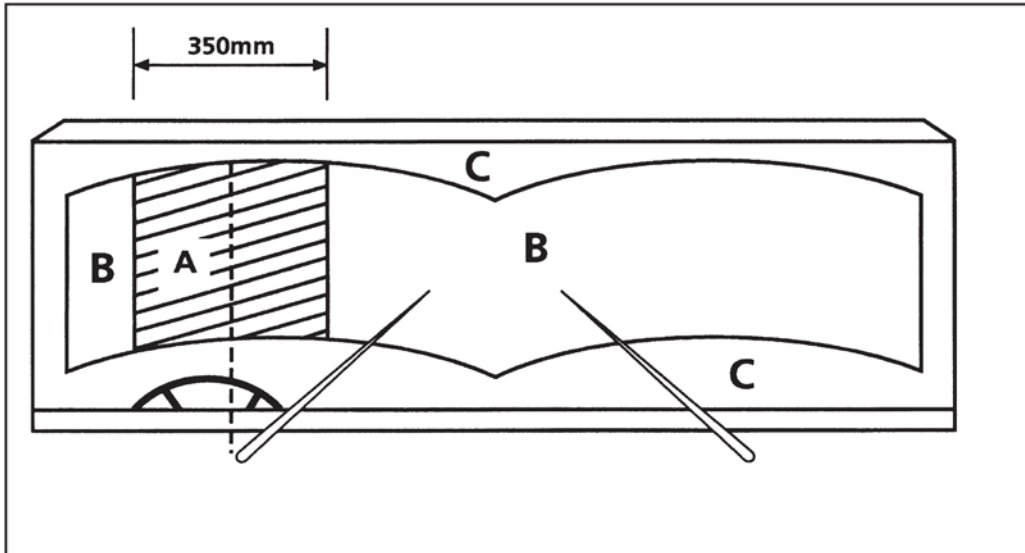

Zone "A" is 350mm wide, in the swept area of the screen and centred on the centre of the steering wheel.

Zone "B" is the remainder of the swept area.

Zone "C" is the remainder of the screen not covered by Zones "A" or "B".

Windscreen.

Examiners should have regard for the three separate "zones" when assessing damage or discolouration. A greater amount of damage or discolouration could be accepted in zone "C" than in zone "B". Likewise a greater amount can be accepted in zone "B" than in zone "A" where relatively minor damage would be a Reason for Failure.

When assessing damage, light surface scratches, are not to be considered as damage. However, an area of concentrated scratches such as those caused by prolonged use of a defective wiper blade which significantly obscures vision is to be considered a Reason for Failure if it meets the fail criteria.

Repaired windscreens must be inspected to the same criteria as original unrepaired screens. Repairs must be judged as to whether they interfere with vision. An 'invisible' or barely detectable repair, finished flush with the surrounding glass, does not count as damage even if the repair exceeds the limits of damage allowed in the test.

23 Glass and View of the Road

Application

When checking the view of the road from the driver's seat, the view must not be obstructed by any changes to the original design such as the addition of stickers, pennants, cab decorations, stone-guards or other items which encroach more than 40mm into the swept area.

Video monitors when fitted in the area at the top of the screen to give a view to the rear are acceptable provided they do not obstruct the swept area more than a rear view mirror would. Monitors fitted onto the dash must not encroach into the swept area by more than 40 mm.

Official stickers are permitted to encroach more than 40mm if this is necessary to comply with other regulations, and include road fund licence, operators licence, section 19 permits, vehicle anti-theft scheme stickers issued by the Police Authority, toll payment tag/stickers, vehicle distance or lane indicator lenses and security passes. These should only be considered a reason for failure if they seriously restrict the view to the front.

On many vehicles the original design will place things like instrument panel clusters inside the 40mm area swept by the wipers. Intrusions such as this which are original design features can be ignored, as can damage or unofficial stickers placed inside the 40mm limit but which are hidden by that feature.

Some commercial vehicles have very large screens and have windscreen wipers which cover an area that have no practical use. For the purposes of the annual test, the area of the screen above a horizontal line taken from the driver's eye position, assessed with the driver seated, looking forward in a comfortable upright driving position and with the seat, if adjustable, in its highest position can be ignored other than the area through which the driver is required to view a mirror (front mirrors on HGVs are not required to be viewed through the area swept by the wipers).

Swept area means the area swept by the wipers in their normal operation and does not include any additional area of the screen covered by the wipers to reach the parked position or which the original manufacturer has designed as opaque.

23 Glass and View of the Road

Application

Examples of acceptable features which may intrude into the swept area of the wipers provided they do not seriously impair the driver's view are:

- Vehicle distance or lane indicator lenses
- Automatic windscreen wiper detectors
- Grooves in the windscreen designed to clean wiper blades
- Fresnel lens
- Split windscreens
- Wipers which park adjacent to a central pillar
- Driver's aids such as blinds and their mountings. This includes manufacturer's exterior fixed sun visors.

Examples of unacceptable features are:

- No smoking signs
- Maximum height signs
- Satellite navigation if not chassis makers original equipment (see example below)
- Maintenance information stickers
- Monitors which show the activities at the rear of the vehicle if not chassis maker's original equipment.



Chassis makers original equipment - Pass

Not chassis makers original equipment - Fail

Heavy Goods Vehicle Inspection Manual

23 Glass and View of the Road

Method of Inspection	Reason for Failure
<p>1. Check windscreen for:</p> <ul style="list-style-type: none"> a. damage or discolouration which impairs the driver's view of the road. b. crack(s) passing through the swept area which renders the screen insecure or which impairs the driver's view. c. an obstruction which encroaches more than 40mm into the swept area (see note). d. crack(s) where there is noticeable displacement of the surfaces on either side which has an adverse effect on the condition and operation of the windscreen wipers. e. damage which exposes the inner layer of a laminated screen. <p>2. Check a windscreen or window is not:</p> <ul style="list-style-type: none"> a. so insecure that it is likely to fall out. b. damaged to such an extent it presents a danger to occupants or to other road users. <p>3. Check there is no damage or obstruction of a side window which impairs the driver's view through a mandatory mirror.</p>	<p>1. A Windscreen:</p> <ul style="list-style-type: none"> a. with damage or discolouration which impairs the driver's view of the road. b. with a crack passing through the swept area which renders the screen insecure or which impairs the driver's view. c. with an obstruction which encroaches more than 40mm into the swept area. d. with any crack where there is noticeable displacement of the surfaces on either side which has an adverse effect on the condition and operation of the windscreen wipers. e. with damage which exposes the inner layer of a laminated screen. <p>2. A windscreen or window:</p> <ul style="list-style-type: none"> a. so insecure that it is likely to fall out. b. with damage which presents a danger to occupants or to other road users. <p>3. Damage or obstruction of a side window which impairs the driver's view through a mandatory mirror.</p>

25 Windscreen Wipers and Washers

Application

This inspection applies to all vehicles except those with an opening windscreen or where an adequate view can be obtained by some other means.

Wipers must be able to clear an adequate area of the screen to give the driver a view of the road to the front and in front of both sides of the vehicle.

Washers must provide enough water to enable the wipers to clear the screen effectively.

Frozen washers are to be considered ineffective.

There is no requirement to check that wipers self park.

Method of Inspection	Reason for Failure
<ol style="list-style-type: none"> 1. Check switches that control windscreen wipers and or washers are fitted and operational. 2. Check Wipers: <ol style="list-style-type: none"> a. cover an adequate area. b. work continually when switched on. c. blade(s) are fitted, secure and in an effective condition to clear the screen. 3. Check Washers are effective. 	<ol style="list-style-type: none"> 1. Switches missing or defective. 2. Wipers: <ol style="list-style-type: none"> a. do not move over an adequate area. b. do not work continually when switched on. c. a blade missing, insecure or so deteriorated that it cannot clear the screen effectively. 3. Washers ineffective.

26 Speedometer/Tachograph

Application

This inspection applies to all vehicles.

A vehicle must have a tachograph fitted unless the presenter claims that it is exempt from the tachograph regulations. Exempt vehicles may have either a tachograph or a speedometer fitted.

The check of tachograph seals is by visual assessment only.

All vehicles

A tachograph exemption form must be completed for all vehicles deemed as tachograph exempt, unless the vehicle technical record shows the vehicle is exempt or it is declared on the application form.

If the glass dial is cracked and this does not affect operation this is not a Reason for Failure but the presenter should be advised of the defect.

If the time clock is inoperative this is a reason for failure under 1b (for the tachograph only not the speedometer).

For vehicles fitted with a tachograph

If the tachograph head cannot be opened or if the calibration plaque does not match the vehicle to which it is fitted it should be treated as if the plaque and any relevant seals were not there.

If the vehicle identification on the calibration plaque does not correspond to the vehicle it is fitted to, the vehicle should be failed under RfF 2a. Should the identification refer to the registration mark, the technical record must be checked to ensure it was not a previous registration for the same vehicle. If no vehicle identification is displayed this is not a RfF, there is no requirement to display the registration mark on the calibration plaque.

For vehicles required to be fitted with a tachograph

The tachograph head must only be opened with the steering wheel in the straight ahead position and with the engine switched off.

Installation/calibration plaques expire after 6 years for analogue, 2 years for digital.

It is acceptable for the plaque to contain additional information (e.g. Registration Number, tyre pressures etc.). The plaque is designed to be tamper proof and should show signs of damage if it has been tampered with. The 2 year check is not part of this inspection for analogue tachographs only. However if the examiner notices this plaque is not displayed the presenter must be advised.

26 Speedometer/Tachograph

Application

Analogue tachographs

The electronic check of the indicated 'K' factor is conducted under IM33 but if it differs from the prescribed factor by more than ± 50 it may be a reason for rejection under this section, unless it complies with a further check contained in IM 33.

Check tachograph DIL switch covers and all seals. It will be sufficient to check that they have an approved marking. It is not necessary to identify the sealer.

Digital tachographs

Do not use the Stoneridge speed limiter test equipment on vehicles fitted with digital tachographs.

For vehicles not required to be fitted with a tachograph where a tachograph is used as a speedometer

If a tachograph is used in place of a speedometer (even if the vehicle is tachograph exempt) it is only required to be marked in kilometres per hour, although it may be dual marked in miles per hour also.

Only where the tachograph is marked in KPH alone, will you be required to check the installation/calibration plaque for presence and condition, and the date of calibration is clearly visible.

There is no requirement for a re-calibration of these systems after 6 years provided that the system has been initially calibrated and sealed, and that the calibration plaque and necessary seals remain intact.

Check DIL switch covers and seals for presence and condition and that they are the correct type. It will be sufficient to check that they have an approved marking. It is not necessary to identify the sealer.

If a speed limiter is NOT required, or the speed limiter does not receive the speed signal from the tachograph head, it is only necessary to check the seals inside the tachograph head. There is no requirement for the gearbox sender unit to be sealed. The vehicle technical record will show if a vehicle is speed limiter exempt.

Vehicles fitted with Modular Tachographs

There are presently two types of modular tachograph using encrypted sender units. They are VDO Keinzell 1324 and Stoneridge Electronics (formerly TVI) and are easily identified as they are shaped like a car radio.

Vehicles fitted with Digital and or Modular Tachograph systems have received type approval that permits the use of a 4 wire data transmission cable instead of an armoured cable provided it is used to connect an encrypted sender unit to the tachograph. When used in this arrangement the approval also does not require the cable end connections to be sealed. However, the sender unit itself is still required to be sealed to the gearbox.

26 Speedometer/Tachograph

Application

Where a print out from a digital tachograph cannot be obtained initially (because of a jammed or depleted roll) the presenter should be given the opportunity to rectify this before leaving the test station and the use of PRS would not be appropriate if the defect is rectified.

Identification of Encrypted Sender Units

These appear similar to other sender units and can be positively identified by the cream/beige colour of the sender unit 4 pin bayonet connector. This colour is the same whether the sender unit is the rotating type or a proximity type. It should be noted that when the cable is connected that only a small part of the cream/beige coloured connector is visible.

For the VDO Keinzl 1324 there is an exception to the above colour code when the vehicle is fitted with a TELMA retarder, the socket housing will be red.

The electronic check of the K Factor will be carried out as part of the procedure for IM 33 but any failure where the electronically indicated figure differs from prescribed 'K' factor by more than + or - 50 may be a Reason for Failure under 3.g, unless it complies with a further check contained in IM 33.

If a vehicle is fitted with more than one tachograph and a speed limiter, the speed limiter should operate off all tachographs.



Plastic sleeve seals are acceptable but will require an embossed identification, (see example to left).

Tachograph plaques are required to be tamperproof; this is not a reason for Failure at annual test if they are not tamperproof.

26 Speedometer/Tachograph

Method of Inspection	Reason for Failure
<p>1. For all vehicles, check a speedometer or tachograph is:</p> <ul style="list-style-type: none"> a. fitted. b. complete and operative. c. able to be illuminated. <p>2. Check all vehicles fitted with a tachograph have:</p> <ul style="list-style-type: none"> a. tachograph installation/calibration plaque present and complete. b. a DIL switch cover present, complete and in good condition. <p>3. For vehicles required to be fitted with a tachograph check:</p> <ul style="list-style-type: none"> a. tachograph scale is marked in kilometres per hour. b. tachograph manufacturer’s serial number/data plaque present or showing an “e” marking. c. tachograph installation/calibration plaque is in date. d. where a digital tachograph is fitted that the size of drive axle road tyres comply with calibration plaque. e. “K” factor plaque present. f. seal(s) are present, intact and of the mandatory type. g. an analogue or modular tachograph that the electronically indicated figure does not differ from prescribed ‘K’ factor by more than + or – 50. h. a printout can be obtained from a digital tachograph. 	<p>1. For all vehicles, a speedometer or tachograph:</p> <ul style="list-style-type: none"> a. not fitted. b. incomplete, clearly inoperative, or with dial glass broken or missing (see note in application). c. cannot be illuminated. <p>2. For all vehicles fitted with a tachograph:</p> <ul style="list-style-type: none"> a. tachograph installation/calibration plaque missing or damaged. b. DIL switch cover missing, broken or damaged through interference. <p>3. For vehicles required to be fitted with a tachograph:</p> <ul style="list-style-type: none"> a. tachograph scale not marked in kilometres per hour. (There is no requirement for tachographs to be marked in m.p.h.). b. tachograph manufacturer’s serial number/data plaque missing or not showing an “e” marking. c. tachograph installation/calibration plaque out of date. d. where a digital tachograph is fitted the size of drive axle road tyres do not comply with calibration plaque. e. “K” factor plaque missing. f. seal missing, broken or where a clearly “non mandatory” seal has been fitted in place of an “official” seal. g. an analogue or modular tachograph where the electronically indicated figure differs from prescribed ‘K’ factor by more than + or – 50. h. unable to obtain a printout from a digital tachograph.

26 Speedometer/Tachograph

Method of Inspection	Reason for Failure
<p>3. For vehicles required to be fitted with a tachograph check (continued):</p> <p>i. the digital tachograph displays a 'K' factor reading the same as that shown on the calibration plaque (there is no allowance/tolerance as with analogue type tachographs).</p> <p>4. For vehicles not required to be fitted with a tachograph, where a tachograph is fitted in place of a speedometer check:</p> <p>a. If a speed limiter is required (which is sensed from the tachograph head): the presence of a seal, it is complete and of a mandatory type.</p> <p>b. If a speed limiter is <u>not</u> required: the presence of a seal (within the tachograph head) and it is complete. Note: There is no requirement for the gearbox sender unit to be sealed.</p>	<p>3. For vehicles required to be fitted with a tachograph (continued):</p> <p>i. a digital tachograph that displays a 'K' factor reading different to that shown on the calibration plaque (there is no allowance/tolerance as with analogue type tachographs).</p> <p>4. For vehicles not required to be fitted with a tachograph, where a tachograph is fitted in place of a speedometer:</p> <p>a. If a speed limiter is required (which is sensed from the tachograph head): seal missing, broken or where a clearly "non-mandatory seal has been fitted in place of an "official seal".</p> <p>b. If a speed limiter is <u>not</u> required: a seal (within the tachograph head) missing, broken, or where a clearly "non mandatory" seal has been fitted in place of an "official" seal. There is no requirement for the gearbox sender unit to be sealed.</p>

**27 Horn
Application**

This inspection applies to all vehicles.

Vehicles first used from 1 August 1973 must have a horn that produces a continuous or uniform sound.

If vehicles are fitted with more than one horn only one has to work.

If air horns are connected to the braking system of a vehicle the presenter should be made aware of the possible dangers as well as advising of any leaks from the air horns (there is no requirement to check if air horns operations deplete the braking system).

If more than one horn control is fitted at least one must operate the horn.

Method of Inspection	Reason for Failure
<p>1. Check that a Horn control is:</p> <ul style="list-style-type: none"> a. fitted. b. reached easily from the driving seat. c. secure. <p>2. Check the Horn:</p> <ul style="list-style-type: none"> a. operates. b. is loud enough to be heard by other road users. c. sound is continuous or uniform. d. is secure. 	<p>1. Horn control:</p> <ul style="list-style-type: none"> a. missing. b. cannot be reached easily from the driving seat. c. insecure. <p>2. Horn:</p> <ul style="list-style-type: none"> a. does not work. b. is not loud enough to be heard by other road users. c. sound not continuous or uniform. d. insecure.

**28 Driving Controls
Application**

This inspection applies to all vehicles.

From the drivers seat operate driving controls, except those for brakes and steering which are checked under other items, to see that they function correctly and are complete.

Examples of driving controls which need to be inspected are:

1. Gear control.
2. Accelerator pedal.
3. Clutch pedal.

The list is not exhaustive.

An air leak from a gear valve is not an RfF.

An accelerator pedal anti slip provision missing or worn smooth is not an RfF.

Method of Inspection	Reason for Failure
<p>1. Check driving controls for:</p> <ol style="list-style-type: none"> a. security. b. completeness. c. fractures, cracks and corrosion. d. obstructions or impediments in its travel. e. functioning correctly. f. the presence of rubbish or other items likely to interfere with the proper control of the vehicle. g. the presence of a pedal anti-slip provision, its security completeness and condition. <p>2. Check the designated engine stop control for presence and operation.</p>	<p>1. A driving control:</p> <ol style="list-style-type: none"> a. insecure. b. incomplete. c. fractured, cracked or excessively corroded. d. obstructed or impeded in its travel. *e. obviously not functioning correctly. f. with the presence of rubbish or other items likely to interfere with the proper control of the vehicle. g. pedal anti-slip provision missing, loose, incomplete or ineffective. <p>2. Engine stop control missing or inoperative.</p>

**30 Steering Control
Application**

This inspection applies to all vehicles.

Cracks in the plastic covering do not necessarily mean that a spoke is fractured.

This inspection does not apply to drivers' aid steering wheel knobs.

Unless specified by the manufacturer vehicles fitted with power steering must be checked with the engine running.

“Free Play” must not be confused with movement caused by the compression of steering joints etc. This operation should be carried out with light finger pressure to distinguish the feel of the steering wheel when it meets a resistance.

Certain types of steering column might show some movement not due to excessive wear, e.g. those fitted with universal joints or flexible couplings.

Free play at the steering rim in excess of 1/30 of the steering wheel diameter for a rack and pinion mechanism is considered a reason for failure. For other types of mechanism free play in excess of 1/5 of the wheel's diameter is considered a Reason for Failure. The acceptable free play for a range of wheels is shown below.

WHEEL DIAMETER	RACK AND PINION STEERING		OTHER TYPES OF STEERING
	CONVENTIONAL	WITH STEERING WHEEL AHEAD OF THE RACK AND WITH A NUMBER OF JOINTS	
380mm (15")	13mm (0.5")	48mm (1.9")	76mm (3")
455mm (18")	16mm (0.6")	57mm (2.3")	90mm (3.6")
530mm (21")	18mm (0.7")	67mm (2.6")	106mm (4.2")
610mm (24")	21mm (0.8")	77mm (3.3")	122mm (4.8")

Heavy Goods Vehicle Inspection Manual

30 Steering Control	
Method of Inspection	Reason for Failure
<p>1. Check the steering column:</p> <ul style="list-style-type: none"> a. has no excessive end float, when applying an upward and downward pressure to the steering wheel in line with the column. b. has no excessive side play indicating a badly worn top bearing or insecure top mounting bracket, by pulling and pushing the rim. c. flexible coupling and universal joint for condition and security. d. coupling clamp bolt or locking device is present and secure. e. adjustment device condition. <p>2. Check the Steering Wheel:</p> <ul style="list-style-type: none"> a. security. b. condition. c. hub retaining device is present and secure. <p>3. With the steered wheels in the straight ahead position lightly rotate the steering wheel to the left and right and note the amount of free play.</p>	<p>1. Steering column:</p> <ul style="list-style-type: none"> a. with excessive movement of centre of steering wheel in line with the column (end float). b. with excessive side play indicating a badly worn top bearing or insecure top mounting bracket. *c. flexible coupling or universal joint deteriorated, with excessive wear or insecure. *d. couple clamp bolt or locking device missing or loose. e. with an adjustment device worn to such an extent that it would render the column insecure. <p>2. Steering Wheel:</p> <ul style="list-style-type: none"> *a. loose. b. hub, spoke or rim fractured or cracked. The cover torn with jagged edges which may injure the driver. c. hub retaining device not fitted or loose. <p>3. Free play in system which is outside the prescribed limits.</p>

33 Speed Limiter

Application

This inspection applies to all vehicles which are required to be fitted with a speed limiter.

Vehicles required to be fitted with a speed limiter are:

- A. A vehicle first used from 1 January 1988 with:
 - a design gross weight of more than 12000kg and
 - a maximum speed capability exceeding 56 mph (90 km/h), if a speed limiter were not fitted must be fitted with a speed limiter set at a maximum stabilised speed of 56 mph (90 km/h).

- B. A vehicle first used from 1 August 1992 until 30 September 2001 with:
 - with a design gross weight of more than 7500kg and not exceeding 12000kg and
 - a maximum speed capability exceeding 60mph (96.5km/h) if a speed limiter were not fitted must be fitted with a speed limiter set at a maximum of 60 mph (96.5 km/h).

- C. A vehicle first used from 1 October 2001 until 31 December 2004 with a Euro 3 Diesel or Gas engine (See note) with:
 - a design gross weight of more than 3500kg and not exceeding 7500kg and
 - a maximum speed capability exceeding 90km/h if a speed limiter were not fitted must be fitted with a speed limiter set at a maximum stabilised speed of 56 mph (90 km/h) from 1 January 2007.

- D. A vehicle first used from 1 October 2001 until 31 December 2004 with:
 - a design gross weight of more than 7500kg and not exceeding 12000kg and
 - a maximum speed capability exceeding 90 km/h if a speed limiter were not fitted must have a speed limiter set at 56 mph (90 km/h).

- E. A vehicle first used from 1 January 2005 with:
 - a maximum design gross weight of more than 3500kg and not exceeding 7500kg
 - a maximum speed capability exceeding 90km/h if a speed limiter were not fitted must be fitted with a speed limiter set at a maximum stabilised speed of 90 km/h from 1 January 2008.

- F. A vehicle first used from 1 January 2005 with:
 - a design gross weight of more than 7500kg and not exceeding 12000kg and
 - a maximum speed capability exceeding 90km/h if a speed limiter were not fitted must be fitted with a speed limiter set at a maximum stabilised speed of 90 km/h.

33 Speed Limiter

Application

Some vehicles first used from 1 October 2001 until 31 December 2004 may have been approved to Directive 70/220/EC or fitted with Euro 2 engines. These vehicles are exempt from the speed limiter fitting requirements for Group C. Where exemption is claimed at time of test this should be accompanied by an operator's declaration of exemption and where necessary supported by manufacturer's confirmation of emission test standard, unless the vehicle is marked speed limiter exempt on the technical record. **All the following listed vehicles have already been confirmed by their manufacturers as being exempt and no further proof is required for these vehicles:**

Any Petrol engine or petrol engine converted to run on LPG

Citroen Relay 2.0 litre and 2.2 litre HDi engines

DAF 45, 7.5 ton vehicles (all) except DAF 45 marked as LF. (LF is marked on the N/S of the radiator grill.)

Fiat Ducato with 2.0 litre engines (engine code RHV).

Ford Transit (all).

Isuzu models NPR, NQR, and NKR with T, V, W, X or 1(one) as the 10th VIN character.

Iveco Cargo all, except vehicles with engine code F4AE---

Iveco Daily all, except vehicles with engine code F1CE---, 8140.43B, 8140.43N and 8140.43S with a PIC code 'G.' (the PIC code is applicable to the 8140.43S only, the PIC code can be found on the ID plate on the shut panel for the bonnet identified by the third character.)

LDV (all).

Mitsubishi Canter with 'R' as the 12th VIN character.

Nissan Interstar all, except vehicles with engine code ZD3-A202, G9U-A754 & G9U-A724.

Nissan Primastar All models.

Peugeot Boxer 2.0 litre and 2.2 litre HDi engines.

Renault Master all, except vehicles with engine code ZD3-A202, G9U-A754 & G9U-A724.

Renault Trafic All models.

Vauxhall/Opel Movano with E, F, G, J, K, L, M, N, P, T or W as the 7th VIN character. **Vauxhall/Opel Vivaro** (all).

Volkswagen (all except 2.5lt/2.8lt 109bhp/158bhp engine codes AVR & AUH respectively).

Other vehicles which are exempted by regulations are:

Vehicles owned or used by the Secretary of State for Defence and used for naval, military or air force purposes. If the vehicle is being used the driver must be under the direct orders of a member of the armed forces of the Crown.

Vehicles being used for fire brigade (in England and Wales fire and rescue authority), ambulance and police purposes.

Vehicles which are an emergency tactical response vehicle operated by or on behalf of Her Majesty's Prison Service and used primarily for the purpose of transporting people or equipment (or both) to restore order within Her Majesty's prisons or immigration detention centres.

33 Speed Limiter**Application**

If for any other reason the vehicle presenter claims a valid exemption that is different from the technical record, form VOSA 74 V2 must be completed.

Check that a speed limiter plate is securely fitted in the driver's compartment. It is acceptable for the plate to be fitted in the driver's door jamb. If fitted on a window and facing outward the details must be able to be read by a person of average height.

The character and composition of the plate and size of the lettering are not important provided the details are legible.

It is acceptable for the limiter to be wired through the "ignition" switch but any other device which would allow disconnection of the speed limiter whilst driving is unacceptable.

Early tachographs had covers with a masked area over the access port to interrogate tachograph. These are still to be found although the tachograph scheme has been instructed to cease the fitting of such. Do not remove this type of DIL switch cover at the time of test as it is easy to inadvertently make contact with one of the switches and completely alter the 'K' factor. This means that the test equipment cannot be used and the presenter should be asked to provide tachograph chart evidence of speed limiter operation as described below.

Clear DIL switch covers are acceptable at the time of test, although once again they are no longer acceptable under the Tachograph approved scheme and centres should no longer fit them.

Speed Limiter Integrity Check Using Electronic Device. Not applicable to vehicles fitted with digital tachographs. Refer to section 26 headed digital tachographs.

1. Open the tachograph head. If seals need to be removed from within the tachograph head then do so. Plug the speed simulator jack plug into the tachograph head and close the head. Seals can only be removed and replaced by approved tachograph sealing centres or authorised DVSA staff.
2. The machine will establish the pre set 'K' factor. Check that this is within + or - 50 digits of the 'K' factor displayed on the tachograph calibration plaque. A number of manufacturers have dual marked plaques where the 'W' factor and the 'K' factor are the same and are in the format "W =K=" followed by the associated figure. Other configurations found are no 'W' or 'K' on the plaque but marked Imps / km or Impulses per kilometre, as the K factor is the number of electronic impulses required to record the distance of one kilometre travelled, this is acceptable.
3. Start engine and run at 1200-1500 rpm. Input a simulated speed to 80km/h. Check that the tachograph indicates the same speed. Gradually increase the simulated speed in 1 km/h steps. Note the speed indicated on simulator's digital display when the speed limiter operates. This can be identified by a reduction in the engine RPM, or a change in the engine note, or vibration indicating that the fuel supply is being reduced.

33 Speed Limiter

Application

If it is found that the indicated figure differs by more than ± 50 from the prescribed "K" factor a further check should be made.

In line with normal procedures where the 'K' factor indicated by the electronic device does not exactly match the displayed 'K' factor, input the displayed 'K' from the plaque into the electronic device.

It is imperative that the tachograph head is closed before the remainder of the test is conducted so that no damage to the tachograph can take place should the vehicle's steering wheel be accidentally turned.

Set the simulated speed to 80 km/h and check the speed indicated by the tachograph. Note the difference, if any, in speed between that displayed on the electronic device and the tachograph.

If there is a difference in the electronic device's simulated speed and the speed indicated on the tachograph, and this difference is greater than 5km/h, either higher or lower, then the vehicle should be failed under Reason for Failure 3g of IM 26 as this defect relates to the tachograph rather than the speed limiter.

Continue to undertake a check of the vehicle's speed limiter. Remember to use the electronic device's simulated speed as the indication of the true road speed at which the road speed limiter operates.

On some vehicles, the electronic device will be unable to indicate the speed at which the speed limiter operates. Under these circumstances tachograph chart evidence of the vehicle while in service can be used to verify the operation of the speed limiter. The voluntary submission of 5 consecutive tachograph charts from the previous 28 working days can be used to establish the maximum operational speed. The vehicle should be failed for Reason for Failure 3a or 3b if the tachograph chart shows a speed trace of more than 95 km/h for vehicles in Groups A,C,D,E and F and of more than 106.5 km/h for vehicles in Group B. The vehicle must have exceeded this speed for at least ten minutes.

If the speed simulator is unable to be used, and there are no tachograph charts available for inspection, the vehicle should be passed. DVSA Enforcement should be advised of the inability to check this test item.

Only speed limiter calibration certificates are acceptable at retest. If a certificate relating to the tachograph is presented the vehicle must be physically rechecked.

**33 Speed Limiter
Application**

The inspection of speed limiters is only for the parts which are visible without dismantling.

It is acceptable to receive verification from a speed limiter calibrator that a vehicle can not exceed the speed requirement for the installation of a speed limiter. A relevant exemption form should be completed and forwarded to record section at Ellipse, Padley Road, Swansea.

Speed limiter inspections should not be carried out on vehicles with AS Tronic/Optidrive gearboxes.

‘K’ plaques placed over seals. Do not remove these plaques and use tachograph charts as evidence of the speed. Inform the enforcement staff so they can contact the tachograph centre of the incorrect practice.

The 13-18 tachograph can suffer from earth problems, this can be cured by moving the vehicle, ensure the presenter moves the vehicle if this is required.

When performing the speed limiter check, if the tachograph seals are clearly non mandatory or missing from the head do not perform the speed limiter inspection and fail the vehicle under IM 26.3.f.

Plastic speed limiter seals are acceptable if they are properly marked with a sealer identification.

Because of the way the Romatic Speed Limiter operates if you encounter an over speed situation please use the tachograph charts for confirmation that the limiter is defective before failing vehicles fitted with this device.

Method of Inspection	Reason for Failure
1. Check the Speed Limiter Plate is: <ul style="list-style-type: none"> a. fitted. b. secure. c. conspicuously positioned. d. clearly and indelibly marked with the speed at which the speed limiter has been set. Acceptable in mph or km/h. 	1. Speed Limiter Plate: <ul style="list-style-type: none"> a. missing. b. insecure. c. not in a conspicuous position. d. not clearly and indelibly marked with the set speed.

33 Speed Limiter	
Method of Inspection	Reason for Failure
<p>2. Check the Set Speed marked on Speed Limiter Plate:</p> <ul style="list-style-type: none"> a. 90km/h (56 mph) for a vehicle described in Application section Groups A, C, D, E & F. b. 96.5 km/h (60 mph) for a vehicle described in Application section Group B. <p>3. Check the response speed of the limiter.</p> <p>4. Check the Speed Limiter is:</p> <ul style="list-style-type: none"> a. fitted. b. secure. c. operating correctly and actuating rods/cables are connected and not damaged. d. connected by authorised means and the wiring is not easily disconnected. e. tamperproof, a device is fitted and is not defective and has not been interfered with. 	<p>2. Set Speed marked on Speed Limiter Plate greater than:</p> <ul style="list-style-type: none"> a. 90km/h (56 mph) for a vehicle described in Application section Groups A, C, D, E & F. b. 96.5 km/h (60 mph) for a vehicle described in Application section Group B. <p>3. Response speed of:</p> <ul style="list-style-type: none"> a. 92 km/h or more for a vehicle described in Application section Groups A, C, D, E & F. b. 102 km/h or more for a vehicle described in Application section Group B. <p>4. Speed Limiter:</p> <ul style="list-style-type: none"> a. not fitted. b. insecure. c. actuating rods/cables disconnected or damaged so that the operation is obviously affected. d. wiring disconnected or can easily be disconnected by unauthorised means. e. tamperproof device missing or defective or showing obvious signs of interference.

**34 Pressure/Vacuum Warning and Build Up
Application**

This inspection applies to all vehicles, except those with an unladen weight of less than 3050kg where the vacuum reservoir is coupled direct to the engine induction manifold. These vehicles do not require a pressure/vacuum warning device (if it is not possible to determine the unladen weight of a vehicle, the presenter should be given the opportunity to produce some evidence of the unladen weight before failing the vehicle).

Vehicles used from 1 April 1983 can be fitted with either a visual warning device or an audible warning device. If both are fitted only one need work. Vehicles first used before 1 April 1983 must be fitted with a visual warning device. If an audible warning device is also fitted this is considered to be an addition to the mandatory requirement.

A number of vehicles, among them Mercedes 515, 609, 612, 614, 709 and Iveco Daily models were approved without a warning device and should not be failed for a warning device not fitted.

If there is no reservoir in a vacuum system a warning device is not required.

If the vehicle has full power hydraulic brakes, gauges are not normally fitted and there are no appreciable sounds when the brakes are applied. To check for the compliance with item 2 in Mol use the procedure shown in Item 71.

If gauges are not marked, take 3 bar (45 psi) for air systems and 25 to 30cm (10 to 12 Inches) for vacuum systems as indicating minimum effective working condition.

The time to reach minimum effective working pressure should normally be within 3 minutes for pressure systems and 1 minute for vacuum systems. With Type Approved vehicles designed to draw a trailer a build-up time of 6 minutes is acceptable. If, however, the time recorded for the vehicle is appreciable longer than expected from that type of vehicle, this should be taken to indicate undue wear or a defect in the equipment.

34 Pressure/Vacuum Warning and Build Up

Method of Inspection	Reason for Failure
<ol style="list-style-type: none"> 1. Check the mandatory visual warning device: <ol style="list-style-type: none"> a. can be seen by the driver in all lighting conditions. b. is fitted and is working correctly. 2. Deplete the air or vacuum system by applying the foot brake, when the warning device operates there must be two further assisted brake applications. 3. Fully deplete the system and run the engine at just below governed speed and note the time for the warning device to show minimum effective working condition. 	<ol style="list-style-type: none"> 1. A mandatory visual warning device: <ol style="list-style-type: none"> a. can not be seen by the driver in all lighting conditions. b. not fitted or not working correctly. 2. Not enough pressure or vacuum to give at least two fully assisted brake applications after the warning device has indicated minimum effective working conditions. *3. Time to reach minimum effective working pressure is more than 3 minutes for pressure systems and 1 minute for vacuum systems (6 minutes for type approved vehicles designed to draw a trailer).

36 Hand Lever Operating Mechanical Brakes

Application

This examination applies to all vehicles fitted with a mechanical parking brake.

Method of Inspection	Reason for Failure
<p>1. Check the Brake lever:</p> <ul style="list-style-type: none"> a. for fractures or cracks. b. for excessive corrosion. c. security d. position so that it can be operated satisfactorily. e. by applying the brake slowly and checking that it is not impeded in its travel. f. when fully applied in the “on” position remains there when knocked on each side and the top. g. is not at the end of its working travel. h. does not have excessive side play within a pivot. i. pivot operation. j. releases correctly. <p>2. Check the Pawl mechanism:</p> <ul style="list-style-type: none"> a. and mountings for condition. b. spring is pushing teeth into positive engagement with ratchet teeth. <p>3. Check locking and/or retaining devices for presence and or security.</p>	<p>1. Brake lever:</p> <ul style="list-style-type: none"> a. fractured or cracked. b. excessively corroded. c. insecure. *d so positioned that it cannot be operated satisfactorily. e. impeded in its travel. **f is not held in the “on” position when knocked. g has no further possible travel when the brake is fully applied. h pivot with side play such that it is likely to fail. i. pivot is tight in operation. j. does not release correctly. <p>2. Pawl mechanism:</p> <ul style="list-style-type: none"> a. and/or mountings in such a condition that early failure is likely. b. pawl spring is not pushing teeth into positive engagement with ratchet teeth. <p>3. Locking and/or retaining devices missing or insecure.</p>

37 Service Brake Pedal	
Application	
<p>This examination applies to all vehicles.</p> <p>Power operated braking systems where the foot valve is fully open before the pedal is fully depressed do not require any reserve travel.</p>	
Method of Inspection	Reason for Failure
<p>1. Check Brake pedal:</p> <ul style="list-style-type: none"> a. anti -slip provision presence, security and condition. b. condition. c. does not foul other parts of the vehicle. d. has sufficient reserve travel when fully depressed. <p>2. Check Brake pedal and assembly:</p> <ul style="list-style-type: none"> a. is secure. b. Is complete, with no fractures, cracks, or corrosion. c. pivot operation. d. releases correctly. 	<p>1. Brake pedal:</p> <ul style="list-style-type: none"> a. anti-slip provision missing, loose, incomplete or ineffective. b. has excessive side play. *c. fouling other parts of the vehicle. d. insufficient reserve travel when fully depressed. <p>2. Brake pedal or assembly:</p> <ul style="list-style-type: none"> a. insecure. *b. incomplete, fractured, cracked, or corroded. c. pivot is tight in operation. d. does not release correctly.

38 Service Brake Operation

Application

This examination applies to all vehicles and trailers.

Vehicles and trailers on which anti-lock brakes are mandatory

Type of Vehicle	Date
Motor vehicles with design GVW greater than 16000kg and authorised to tow a semi-trailer or a centre axle drawbar trailer with total design axle weights greater than 10000kg or a drawbar trailer with design GVW greater than 10000kg. (an O4 trailer) See examples 1 and 2 below to determine whether a motor vehicle needs antilock brakes	First used from 1 April 1992 and up to 30 April 2002
Motor vehicle with design GVW greater than 3500kg	First used from 1 May 2002
Semi-trailers and centre axle drawbar trailers with a design total axle weight of more than 10000kg	Manufactured from 1 October 1991
Semi-trailers and centre axle drawbar trailers with a design total axle weight of more than 10000kg and which do not have a load sensing valve	Manufactured from 1 October 1982 to 30 September 1991
Semi-trailers and centre axle drawbar trailers with a design total axle weight of more than 3500kg	Manufactured from 1 May 2002
Full drawbar trailers (turntable type) with a design GVW of more than 10000kg	Manufactured from 1 October 1991
Full drawbar trailers (turntable type) with a design GVW of more than 10000kg and which do not have a load sensing valve	Manufactured from 1 October 1982 to 30 September 1991
Full drawbar trailers (turntable type) with a design GVW of more than 3500kg	Manufactured from 1 May 2002

Anti lock Brake exempt vehicles

A public works vehicle which has a maximum design GVW of 7500kg and which is specifically designed for use and used solely for the purpose of street cleansing.

38 Service Brake Operation

Application

How to determine if a drawing vehicle first used from 1st April 1992 and before 1 May 2002 needs antilock brakes.

Example 1



Semi-Trailer

or



Rigid and Drawbar Trailer

DGVW 18000kg

DGTW greater than 28000 - (DGTW-DGVW>10000)

Anti-lock brakes required.

Example 2



Semi-Trailer

or



Rigid and Drawbar Trailer

DGVW 18000kg GTW 27000kg (DGTW-DGVW<10000)

Anti-lock brakes may be required if:

1. the drawing hitch is rated at more than 10000kg or
2. the tractor is presented for test with a semi-trailer which has Total Axle Weight greater than 10000kg or
3. the drawing vehicle is presented for test with a trailer which has DGVW greater than 10000kg

The tow hitch should have a manufacturer's identification plate showing the hitch capacity.

For some brake systems a small amount of creep may be due to elasticity in the brake components.

For test purposes it will only be possible to check the static part of the warning light sequence. Some systems require movement of the vehicle but this is not part of the test.

38 Service Brake Operation

Application

If a trailer is submitted for test coupled to a motor vehicle which has no power supply for the trailer anti-lock system the test should be suspended on the grounds that the trailer has not been accompanied by a suitable drawing vehicle. The presenter should be informed of this on form VTG12.

If a trailer does not have a warning light, this is acceptable provided that the drawing vehicle has a trailer warning light fitted in the cab. If neither the tractor nor trailer has a warning light and there is a separate connector for the anti-lock system the test should be suspended as described above. If neither has a warning light and the trailer anti-lock is operated through the stop lamp circuit the trailer should be failed under Reason for Failure 5a.

Vehicles and trailers fitted with ABS are not required to have a LSV. However, if an LSV is fitted and known to be a standard fitment this is a RfF if it is removed or disconnected refer to IM59.

There is no requirement to check the colour of Malfunction Indicator system warning lamps.

ABS, ABS/EBS and ABS/EBS/ESC requirements

ABS only vehicles

Vehicles fitted with ABS only must have a mandatory warning malfunction indicator lamp (MIL) that illuminates when the system is energised (ignition or battery master switch on). It can be any colour, though they are usually red, yellow or amber. It must go out after a short period or when the engine is started but can then come back on and remain on until the vehicle speed exceeds approximately 5 kph (3 mph). It is not necessary to move the vehicle to check the speed-activated function provided the lamp does go off momentarily.

Trailers fitted with ABS must have either; a warning lamp (usually green and fitted on the trailer headboard), or if this is not present then there must be a trailer ABS warning lamp in the motor vehicle cab of any colour separate from the vehicle warning lamp. If trailer ABS warning lamps are fitted to both vehicle and trailer both systems must work (on some trailers the trailer warning lamp may be extinguished when the ISO7638 cable is fitted).

Other lamps of the same or different colours showing e.g. that trailers are not connected, or are not fitted with ABS may also be fitted to motor vehicles. These are not mandatory and are for information purposes only. If these are illuminated it is not an RfF. It is important to establish that a lit warning lamp is actually showing an ABS defect, and is not an ABS information lamp. The Driver Handbook may be used to establish the function of a lamp.

38 Service Brake Operation

Application

ABS/EBS equipped vehicles

Vehicles fitted with ABS and EBS must have mandatory red and amber/yellow MILs fitted. Drawing vehicles must be fitted with a separate amber/yellow MIL for the trailer, though one red MIL may be shared between tractor and trailer. If separate tractor and trailer Red MILs are fitted they are both required to work.

The red MIL illuminates if there is a foundation brake fault or the prescribed minimum brake performance cannot be met. The red MIL must illuminate with system initialisation though this may not be clearly evident as in some cases the sequence is extremely fast and may be missed. In this circumstance if modulator cycling can be heard it is acceptable to pass the vehicle. If a red MIL stays lit or is flashing this is a reason for failure.

The amber/yellow lamp illuminates if there is an electronic fault

The amber/yellow MILs must illuminate with system initialisation though this may not be clearly evident as in some cases the sequence is extremely fast and may be missed. In this circumstance if modulator cycling can be heard it is acceptable to pass the vehicle. If the MIL stays lit this is a reason for failure. If the MIL illuminates on system initialisation then goes out and then flashes this should be advised.

ABS/EBS/ESC equipped vehicles

Motor vehicles fitted with ESC must have a separate amber/yellow MIL fitted apart from those used to signal EBS electronic faults. One lamp covers both the motor vehicle and any trailer fitted with ESC towed.

The ESC lamp will be illuminated when the system is switched off, when the system is operating or if a fault is present. It is not required to light up on system energisation, but if it does this is acceptable provided it then goes out after a short period or when the engine is started.

If the vehicle has a switch to manually disable the ESC function, it must not be possible for the switch to be left in the "off" position and the ESC function must be automatically reinstated every time the system is re-energised (ignition turned on.)

Electronic Stability Control Systems are commonly referred to as ESC, but may also be known as ESP/RSC or some other acronym. The MIL for these systems may take various forms and a vehicle should only be failed when the tester is certain that an illuminated lamp indicates an ESC malfunction. This may require reference to the owner's handbook if one is available.

38 Service Brake Operation

Method of Inspection	Reason for Failure
<p>1. Air pressure or vacuum systems: With reservoir at maximum pressure or vacuum, fully depress the pedal and note the change in gauge readings to see if they give indications of a leak in the system.</p> <p>2. Hydraulic systems (other than full power systems), fully depress the pedal and keep it depressed under steady pressure and check:</p> <ul style="list-style-type: none"> a. that the pedal does not creep down under full pressure. b. there is no sponginess. <p>3. Brake systems assisted by engine vacuum: Deplete the vacuum, partly depress the pedal, start the engine, and check if the pedal can be felt to dip.</p> <p>4. Full pressure hydraulic systems: Check that the system pressure is maintained for at least 10 minutes when the brakes are off and the engine is stopped. Loss of pressure will be indicated by the operation of the low pressure warning device (warning light or appearance of semaphore "flag" device).</p>	<p>1. Air pressure or vacuum systems gauge reading drops when pedal depressed indicating a leak in the system.</p> <p>2. Hydraulic systems (other than full power systems):</p> <ul style="list-style-type: none"> a. pedal creeps down when depressed. b. sponginess when pedal depressed. <p>*3. Pedal does not dip when engine started, indicating lack of assistance for brake systems assisted by engine vacuum.</p> <p>4. Full pressure hydraulic system pressure is not maintained for 10 minutes when the brakes are off and the engine is stopped.</p>

Heavy Goods Vehicle Inspection Manual

38 Service Brake Operation

Method of Inspection	Reason for Failure
<p>5. If the vehicle/trailer is fitted with an ABS or ABS/EBS or ESC system, check that required warning lamps:</p> <ul style="list-style-type: none"> a. are fitted. b. illuminate as required when ignition switched on. c. do not indicate a fault. 	<p>5. Any of the required ABS or ABS/EBS or ESC warning lamps:</p> <ul style="list-style-type: none"> a. are missing. b. do not illuminate as required when ignition switched on. c. indicate a fault.
<p>6. Vehicles and trailers fitted with ABS or ABS/EBS or ESC check:</p> <ul style="list-style-type: none"> a. the presence and condition of all visible system components. b. the condition of all visible system wiring. c. all system components for any inappropriate repair or modification. d. the condition and operation of any switch fitted to turn the ESC system on and off. 	<p>6. Vehicles and trailers fitted with ABS or ABS/EBS or ESC:</p> <ul style="list-style-type: none"> a. a system component obviously missing or excessively damaged. b. system wiring excessively damaged. c. a system component inappropriately repaired or modified. d. an ESC system switch insecure or faulty or which does not allow automatic resetting of the ESC function to “on” at system energisation.
<p>7. On Vehicles and trailers both fitted with ISO 7638 (ABS/EBS) lead sockets check an ISO 7638 connecting lead is fitted and being used.</p>	<p>7. On vehicles and trailers both fitted with ISO 7638 (ABS/EBS) lead sockets an ISO 7638 connecting lead not fitted or being used.</p>
<p>8. On a vehicle or trailer on which anti-lock brakes are mandatory check that an ABS system is fitted.</p>	<p>8. A system not fitted to a vehicle where it is mandatory.</p>

39 Hand Operated Brake Control Valves

Application

This examination applies to all hand operated valves on vehicles which operate secondary brakes, trailer brakes, spring brakes and lock actuators. It also applies to trailers fitted with hand operated spring brake valves.

Certain air valves are subject to a slight amount of leakage and this is not a reason for failure.

Method of Inspection	Reason for Failure
<p>1. Check the Control valve:</p> <ul style="list-style-type: none"> a. on a motor vehicle is capable of being operated from the driving position. b. is secure. c. condition. d. is unimpeded in its travel. e. does not leak. f. condition of gate or lever locating mechanism. g. functions correctly. 	<p>1. Control valve:</p> <ul style="list-style-type: none"> a. on a motor vehicle unable to be operated from the driving position. b. insecure. c. fractured, cracked, damaged or excessively corroded. *d impeded in its travel. e leaking. f excessive wear in the gate or lever locating mechanism. *g malfunctioning.

41 Condition of Chassis

Application

This inspection applies to all vehicles and trailers.

For integral construction the term chassis should also be taken to apply to the underframe. For vehicles without a chassis those parts of the body must be examined which take the place of the chassis.

A missing chassis crossmember is not a reason for failure but it is subject to notifiable alteration procedure which may result in a vehicle being down plated.

When assessing corrosion it must only be regarded as a failure if it is sufficiently advanced to obviously impair the strength of a load bearing member.

RfF 2 also includes sliding bogies and their locking mechanisms. It does not include the operating mechanism to move the bogie (these are normally air brake chambers) unless detachment is likely when IM74 should be used.

Seddon 6 x 2 has a 'H' section crossmember fitted forward of the drive axle, there are 2 holes in the bottom flange on each side of the chassis frame and crossmember which were originally for securing the steel spring suspension front spring bracket to the chassis frame. When air suspension is fitted there is no requirement to fit bolts in these 2 holes.

Heavy Goods Vehicle Inspection Manual

41 Condition of Chassis	
Method of Inspection	Reason for Failure
<p>1. Check all main members, cross members and outriggers which have load restraining devices attached (e.g. twistlocks) for:</p> <ul style="list-style-type: none"> a. fractures or cracks. b. advanced corrosion. c. deformation. <p>2. Check frame and/or cross member fastenings for:</p> <ul style="list-style-type: none"> a. security of flitch plates and fastenings. b. condition of welding. <p>3. On integral bodied vehicles and trailers where the body panels provide an important part of the strength of the vehicle check any Integral body replacement panels:</p> <ul style="list-style-type: none"> a. are of a suitable material. b. are adequately secured by an appropriate method. 	<p>1. Any main or cross member or outrigger which has a load restraining device attached:</p> <ul style="list-style-type: none"> a. fractured or cracked or b. with advanced corrosion or c. deformed <p>so that the control of the vehicle is likely to be affected or the load will become insecure.</p> <p>2. Frame and/or cross member fastenings:</p> <ul style="list-style-type: none"> a. insecure flitch plates and/or fastenings or b. a weld breaking away <p>so that the control of the vehicle is likely to be affected or the load will become insecure.</p> <p>3. Integral body replacement panels:</p> <ul style="list-style-type: none"> a. of an obviously unsuitable material. b. not adequately secured by an appropriate method.

42 Electrical Wiring and Equipment

Application

This inspection applies to all vehicles and trailers.

If the battery is only held in place by the cables and by a lip on the carrier this cannot be considered to be secure.

Where it is not possible to inspect batteries for condition and leaks every effort should be made to inspect the area where the batteries are installed to confirm there are no signs of leakage.

When checking the condition and security of the wiring, care needs to be taken when inspecting the high voltage systems of Hybrid Electric Vehicles. These high voltage wires are colour coded orange.

Method of Inspection

Reason for Failure

1. Check all visible wiring for:
 - a. condition and security.
 - b. positioning so that it is unlikely to be chafed or damaged by heat.
2. Check the battery and carrier for:
 - a. security.
 - b. condition.
3. Check switches controlling obligatory lights for security and function.
4. Check trailer electrical sockets for:
 - a. security.
 - b. damage or deterioration.
5. Check all power train equipment for:
 - a. security.
 - b. risk of fire or injury.

1. Wiring:
 - a. not adequately insulated or secured.
 - b. positioned so that it is chafing or likely to be damaged by heat.
2. Battery:
 - a. and/or carrier insecure and likely to become displaced.
 - b. case leaking.
3. Switch controlling an obligatory light insecure or malfunctioning.
4. A trailer electrical socket:
 - a. insecure.
 - b. damaged or deteriorated to the extent that the connecting lead could not be securely connected.
5. A power train:
 - a. insecure.
 - b. presents a risk of fire or injury.

43 Engine and Transmission Mountings

Application

This inspection applies to all vehicles, including Hybrid Electric Vehicles. Where there is separate power train equipment this should be treated as an engine/transmission.

There will only be a failure under this item if a mounting is no longer capable of performing its function of location and support.

Serious fractures in clutch or bell housings which affect the security of the engine or gearbox are a reason for failure.

Method of Inspection	Reason for Failure
<p>1. Check condition of mountings and subframes and their installation to the chassis or underframe for:</p> <ul style="list-style-type: none"> a. security. b. cracks or fractures. c. deterioration. 	<p>1. Any mounting or subframe:</p> <ul style="list-style-type: none"> a. loose. b. cracked or fractured. c. badly deteriorated.

44 Oil Leaks	
Application	
<p>This inspection applies to all vehicles and trailers.</p> <p>Check without operating any equipment other than the engine which may be run at tick-over speed.</p> <p>Very bad oil leaks are a reason for refusing to carry out the test. If the test is suspended for this reason the presenter will be notified of this using form VTG12.</p> <p>Temporary means of preventing leaked oil reaching the ground such as fabricated drip trays consisting of sheet metal supported by wire strands are not acceptable. This does not apply to permanent fittings such as drip trays for feed pipes on tankers.</p> <p>Fabricated repairs to an oil pipe which effectively stop an oil leak are acceptable.</p>	
Method of Inspection	Reason for Failure
<p>1. Check for leakage of any type of oil other than fuel oil.</p>	<p>*1. Any oil leak from any assembly which can deposit oil at a rate of a 75mm diameter pool in 5 minutes or a number of leaks which collectively would deposit oil at the same rate.</p>

45 Fuel Tanks and System

Application

This inspection applies to **all fuel tanks** which are permanently attached to vehicles and to trailers, including gas fuel tanks and cylinders, bottles and other types of fuel container.

Seepage is not a reason for failure.

Fabricated and "emergency" fuel caps are acceptable provided that they function correctly. Where possible the tank cap should be opened to check the sealing arrangements.

Very bad fuel leaks are a reason for refusing to carry out the test. If the test is suspended for this reason the presenter will be notified of this using form VTG12.

If the vehicle is powered by gas and suffers a leak this should be treated in the same manner as a normal fuel leak and VTG12 action taken. The vehicle should be moved to a well ventilated area away from people and buildings. If the leak is of a serious nature evacuate the building and call Health and Safety Branch.

It is not necessary to run the engine but if a leak is present when the engine is running the vehicle should be failed under RfF3a.

It is not necessary to run combustion heaters as part of this inspection.

Heavy Goods Vehicle Inspection Manual

45 Fuel Tanks and System	
Method of Inspection	Reason for Failure
<p>1. Check the fuel tank for security.</p> <p>2. Check tank straps and supports for:</p> <p style="margin-left: 20px;">a. condition and presence.</p> <p style="margin-left: 20px;">b. security and strength</p> <p>3. Check Fuel System for :</p> <p style="margin-left: 20px;">a. leaks.</p> <p style="margin-left: 20px;">b. condition of pipes and that they are complete and secure.</p> <p style="margin-left: 20px;">c. positioning of pipes so that they are unlikely to be fouled by moving parts.</p> <p>4. Check Filler Cap for:</p> <p style="margin-left: 20px;">a. presence.</p> <p style="margin-left: 20px;">b. security:</p> <ul style="list-style-type: none"> • by a positive means, or • such that pressure is maintained on the sealing arrangement. <p style="margin-left: 20px;">c. presence and condition of the sealing washer and that the mounting flange/sealing method is effective.</p>	<p>**1. Tank so insecure on its mountings that it is likely to drop away partially or completely when the vehicle is used.</p> <p>2. A tank strap or support:</p> <p style="margin-left: 20px;">a. broken or missing.</p> <p style="margin-left: 40px;">**b so insecure or weakened that the tank is likely to drop away partially or completely when the vehicle is used.</p> <p>3. Fuel System:</p> <p style="margin-left: 20px;">*a leaking.</p> <p style="margin-left: 20px;">b pipes so damaged (restricted/chafed), insecure or with an inadequate repair such that they are likely to fail and leak which would cause danger to persons on the vehicle or to other road users.</p> <p style="margin-left: 20px;">c pipes damaged or so positioned that they are fouled by moving parts of the vehicle.</p> <p>4. Filler Cap:</p> <p style="margin-left: 20px;">**a missing.</p> <p style="margin-left: 20px;">**b does not fasten securely:</p> <ul style="list-style-type: none"> • by a positive means, or • such that pressure is not maintained on the sealing arrangement. <p style="margin-left: 20px;">**c sealing washer torn, deteriorated or missing, or a mounting flange/sealing method defective such that leakage of fuel is possible.</p>

46 Exhaust Systems

Application

This inspection applies to all vehicles.

Where a diesel engined vehicle is failed for exhaust system leaking, the smoke emission test could be affected by the induction of air into the exhaust system. When presented for retest the emission test should be rechecked.

Slight leaks are acceptable.

Check for the presence of the silencer and assess its effectiveness in reducing, so far as is reasonable, noise caused by the exhaust.

An excessively deteriorated exhaust is not a reason for failure providing RfF 1.a and 1.b do not apply.

Method of Inspection	Reason for Failure
<p>1. Check the condition of the exhaust pipes and silencers for:</p> <ul style="list-style-type: none"> a. security. b. leaks. c. position, so that fumes are unlikely to enter the driver's cab. <p>2. Check the exhaust silencer for:</p> <ul style="list-style-type: none"> a. presence. b. effectiveness. 	<p>1. An exhaust system:</p> <ul style="list-style-type: none"> a. so insecure that it might fall away partially or completely when the vehicle is in use. b. leaking. c. positioned so that fumes are likely to enter the driver's cab. <p>2. An exhaust silencer:</p> <ul style="list-style-type: none"> a. missing. b. ineffective.

48 Suspension

Application

This inspection applies to all vehicles and trailers.

Leaf spring systems:

- The fail criterion is that the leaves are so misaligned that each leaf is not taking a reasonable proportion of the load.
- A leaf spring with a fracture or crack on the curled section which prevents the axle moving in the event of main leaf failure is a reason for failure.
- A "U" bolt should be regarded as loose if there is clear visual evidence that it is not properly fulfilling its function of securing a spring and before it can do so it needs remedial action.
- Surface cracks on laminated semi-elliptical springs are not a RfF.
- It is permissible to have a larger road spring on one side of a vehicle than the other.

Spring Pins:

- The maximum permissible wear in a pin and/or mounting is 2mm for a 12mm diameter pin and 1/8 of the diameter for larger assemblies. For a threaded pin it is the diameter of the threaded part which should be taken into account when assessing wear. These criteria should not be used when checking rubber bushes which should be checked for deterioration of the rubber which could result in excessive movement.
- The maximum side play must not exceed 6mm. This does not apply to a threaded pin and mounting assembly or to rubber bushes or to single spring bogie suspensions.
- Where an anchor/shackle pin is secured at one end the maximum amount of movement at the free end should not exceed 1mm for smaller assemblies, increasing to 2mm for larger assemblies.

Slipper brackets:

- Rebound pins where fitted as standard should be correctly located.
- Worn slipper brackets are a RfF when worn to the extent they could, at the time of the inspection, clearly affect the movement or correct location of the road spring (or have allowed the spring leaf to damage the chassis).

Air/Fluid systems:

- When assessing the significance of leaks it should be remembered that certain pneumatic components are subject to some degree of leakage. Slight seepage producing a thin film of oil on the component is not a Reason for Failure but any sign of dripping is unacceptable.
- Exposure of air bag structural cords is acceptable providing that they are not damaged to such an extent the unit is likely to fail.
- An air bag for holding a lift axle in the raised position must be considered against the same criteria as any other suspension air bag.

48 Suspension

Application

Insecurity of attachment points can best be assessed when the steering and/or brakes are operated.

A fractured and or repaired air bag pedestal if performing satisfactorily and not damaging the air bag is not a RfF.

Independent suspension must be jacked to remove the weight from the suspension joints (suspension hanging freely).

Trailers fitted with HD shock absorbers are not required to be fitted with check straps.

Scania vehicles with air suspension have attachment points for a retaining chain, the omission of the chain is not an RfF.

Tag axles with disabled lift facilities are not an RfF, these may also have the lift operation air bag removed.

Shock Absorbers/Anti Roll Bars:

- Slight seepage producing a thin film of fluid on a shock absorber is not a reason for failure but any sign of dripping is unacceptable.
- Anti roll bar bushes repaired with resin are acceptable providing the repair is adequate resulting in the removal of the excess wear.

A comprehensive list of vehicles where shock absorbers and/or anti roll bars are standard fitment is available from:

Vehicle & Operator Services Agency,
Technical and Support Services,
Ellipse,
Padley Road,
Swansea, SA1 8AN.

On some unladen vehicles the suspension air bellows on one side may be deflated. This is a natural characteristic that occurs after certain types of operation of the electronically governed suspension system. This ensures the chassis frame remains at a constant height at all times.

Before failing a vehicle, two operations should be tried which may re-inflate the bellows:

- A. By using the driver control to raise/lower the vehicles suspension before resetting the suspension to the normal ride height. Ensure this operation is only performed under supervision, or
- B. placing a load on the vehicle with the load simulator while performing a brake test.

If neither operation re-inflates the bellows then the vehicle should fail.

48 Suspension	
Method of Inspection	Reason for Failure
<p>1. All suspension types.</p> <p>Check all suspension components and their attachment points for:</p> <ul style="list-style-type: none"> a. security. b. attachment. c. condition. d. general condition which may affect the control of the vehicle. e. correct fitment. f. fitment of all bolts and rivets. g. completeness of rubber and bonded bushes. h. defects which would allow a road wheel to foul another part of the vehicle. i. condition of pins, bushes or mountings. j. condition of ball joint dust covers. k. inappropriate repairs or modifications 	<p>1. All suspension types.</p> <p>A suspension component or its attachment point:</p> <ul style="list-style-type: none"> *a insecure. *b disconnected. *c fractured or cracked. *d so damaged, worn, distorted or corroded that it adversely affects its function. *e incorrectly located or fitted. *f bolt or rivet missing. *g rubber or bonded bush deteriorated. *h defective such that a wheel could foul any other part of the vehicle. *i with wear in a pin, bush or mounting exceeding the prescribed limit. *j. a ball joint dust cover missing, insecure, excessively damaged or severely deteriorated to the extent that it would no longer prevent the ingress of dirt etc.. *k. with an inappropriate repair or modification which has seriously weakened the component.

48 Suspension	
Method of Inspection	Reason for Failure
<p>2. Check Leaf Springs and Fixings for:</p> <ul style="list-style-type: none"> a. condition of pins and mountings. b. condition of leaves (repairs by welding are not acceptable). c. correct alignment of leaves. d. condition of spring fixing pins. e. presence of slipper bracket rebound pin. f. security between a spring and the axle. g. presence of shackles or anchor pins. h. condition of slipper brackets. i. general condition. j. security and presence of a locking device from a shackle or anchor pin. 	<p>2. Leaf Springs and Fixings:</p> <ul style="list-style-type: none"> *a. wear in spring pins/bushes or mountings exceeding the prescribed limit. *b. a fractured or cracked leaf or one repaired by welding. *c. spring leaves splayed beyond the prescribed limits or fouling any other part of the vehicle. *d. movement in a spring fixing pin in excess of the prescribed limits. *e. slipper bracket rebound pin missing or incorrectly located. *f. relative movement or displacement between a spring and the axle. *g. a missing shackle or anchor pin. *h. a worn slipper bracket. *i. so corroded, pitted or seriously weakened that it is likely to fail. *j. an insecure or missing locking device from a shackle or anchor pin.

48 Suspension	
Method of Inspection	Reason for Failure
<p>3. Check Coil Springs or Torsion Bars for:</p> <ul style="list-style-type: none"> a. completeness. b. condition (repairs by welding are not acceptable). c. general condition that it is likely to fail. d. condition and security of torsion bar fixings, any adjustment assemblies correctly fitted and securely locked. e. for correct fitment. <p>4. Air/Fluid Suspension Systems. Check valves, pipes, valve linkage, bellows and displacer/ accumulator unit for:</p> <ul style="list-style-type: none"> a. correct positioning, inflation and/or condition b. fouling by other parts or leaking. c. presence of check straps and their condition. d. security. e. pipe security. f. leaking. 	<p>3. Coil Spring or Torsion Bar:</p> <ul style="list-style-type: none"> *a. incomplete. *b. fractured, cracked or repaired by welding. *c. corroded, pitted, or seriously weakened so it is likely to fail. *d. torsion bar fixings with excessive free play, insecure, or an adjustment assembly incorrectly fitted and/or insecurely locked. *e. incorrectly located or fitted. <p>4. Air/Fluid Suspension System valves, pipes, valve linkage, bellows and displacer/ accumulator unit:</p> <ul style="list-style-type: none"> *a. displaced, deflated, kinked and/or so damaged/deteriorated that it is likely to fail. *b. fouled by other parts or leaking. *c. with check strap missing or defective. *d. insecure. *e. pipe insecure. *f. leaking.

Heavy Goods Vehicle Inspection Manual

48 Suspension	
Method of Inspection	Reason for Failure
<p>5. Check Bonded Suspension Units for:</p> <ul style="list-style-type: none"> a. condition of the bonding between flexible element and metal so that part of the unit is unlikely to fail. b. condition of unit so that it is capable of carrying out its proper function. <p>6. Check Shock Absorbers for:</p> <ul style="list-style-type: none"> a. presence. b. condition and security. c. leaks. d. condition of the rubber bush or pivot. e. presence and condition of linkage and bracket. <p>7. Check Anti roll bars for:</p> <ul style="list-style-type: none"> a. presence. b. security. c. condition. <p>8. Check Anti roll bar linkages/brackets or bushes for:</p> <ul style="list-style-type: none"> a. presence. b. condition. <p>9. Check All suspension types for condition and function.</p>	<p>5. Bonded Suspension Unit:</p> <ul style="list-style-type: none"> *a with failure of bonding between flexible element and metal so that part of the unit is likely to fail. *b. unit is so damaged or deteriorated that it is no longer capable of carrying out its proper function. <p>6. Shock Absorber:</p> <ul style="list-style-type: none"> *a. missing from a vehicle on which it is a standard component. *b. with an anchorage fractured, unit insecure or with a sleeve damaged so that the unit is not functioning correctly. *c. leaking . *d. with an excessively worn rubber bush or pivot. *e. linkage missing, linkage bracket cracked so that it is likely to fail, fractured or cracked or excessively worn. <p>7. Anti roll bar:</p> <ul style="list-style-type: none"> *a. missing from a vehicle on which it is a standard component. *b. insecure. *c. fractured, cracked, severely distorted or so corroded or worn that its strength is seriously reduced. <p>8. Anti roll bar linkage/bracket or bush:</p> <ul style="list-style-type: none"> *a. missing. *b. fractured or cracked and likely to fail, or excessively worn. <p>*9. A suspension unit so weak that the body or other part of the vehicle is fouling the road wheels or is likely to do so if the vehicle is laden.</p>

53 Axles, Stub Axles and Wheel Bearings

Application

This inspection applies to the steered wheels of all vehicles and trailers.

A steered axle is one which has a king pin or ball joints and can be turned to a left and right lock. An axle ceases being steered when it is fixed in the straight ahead position.

When assessing excessive wear, play or king pin clearance (lift) account must be taken of any information given below and/or manufacturers' data.

With the wheels on the ground king pin clearance is assessed between the stub axle upper yoke and beam axle using feeler gauges.

With the wheels off the ground king pin clearance may be measured between the stub axle lower yoke and beam axle.

For vehicles fitted with a "Hives" type thrust bearing any clearance greater than 1.6mm would be considered excessive and in the case of any other type of bearing lift greater than 1.0mm.

King pin and bushes. Any movement greater than 10mm on a 500mm diameter wheel is considered excessive. For wheels of different diameter the maximum allowable movement should be in proportion to this figure.

Wheel bearing free play can be isolated by applying the service brake.

Mercedes Sprinter range of vehicles have front suspension ball joints without springs, these joints are allowed up to 3.0 mm of axial play (lift) and 3.0 mm of radial play. Rejection is only justified when play exceeds the manufacturer's limits.

On a trailer steered axle where the axle has been welded in the straight ahead position this is not a Reason for failure. If steered axles are permanently locked in the straight ahead position a VTG10 is required.

Steered axles manufactured by BPW have a maximum clearance of 12 mm.

Renault Mascot vehicles with a design weight of 3.5 to 6.5 tonnes have a maximum king pin clearance of 1.2 mm.

Heavy Goods Vehicle Inspection Manual

53 Axles, Stub Axles and Wheel Bearings

Method of Inspection	Reason for Failure
<p>1. Check the:</p> <ul style="list-style-type: none"> a. clearance between stub axle and axle beam. b. stub axle and axle beam for cracks. <p>2. Check king pin for:</p> <ul style="list-style-type: none"> a. security in axle beam. b. condition of king pin or bush. c. presence and security of retaining device. <p>3. Check Swivel joints for:</p> <ul style="list-style-type: none"> a. wear. b. security. c. presence and security of locking device. <p>4. While a wheel is rocked using wheel play detector plates in the side to side mode Check Wheel bearings for free play.</p>	<p>1. Stub axle and axle:</p> <ul style="list-style-type: none"> *a. excessive clearance between stub axle and axle beam. *b. cracked. <p>2. King pin:</p> <ul style="list-style-type: none"> *a. excessively loose in axle beam. *b. king pin or bush excessively worn. *c. retaining device missing or insecure. <p>3. Swivel joint:</p> <ul style="list-style-type: none"> *a. excessively worn. *b. insecure. *c. retaining or locking device missing or insecure. <p>*4. Wheel bearing with excessive free play.</p>

**54 Steering
Application**

This inspection applies to all vehicles and to trailers with steered axles.

A steered axle is one which has a king pin or ball joints and can be turned to a left and right lock. An axle ceases being steered when it is fixed in the straight ahead position.

Power steering must be inspected with the engine running. If vehicles are fitted with additional equipment, belt driven from the engine, where the belt may cause a hazard to the inspector they should be tested without the engine running. Examples are belt driven refrigeration compressors and air conditioning.

Exposure of structural cords on power steering hoses is acceptable provided that these cords are not damaged.

The hydraulic fluid level check only applies to readily visible reservoirs which can be checked without removing the reservoir cap.

Any leakage from a power steering system is a Reason for Failure.

For steered wheels on trailers and on any self steered axle, visually check joints and components for wear and condition.

With the road wheels on the ground rock the steering and check all steering joints and fixings.

Instruct the driver to rotate the steering wheel through its full working range. If a lock stop, which is known to be a standard fitment, is missing this is a Reason for Failure. It should be noted however that in some cases there is provision for extra lock stops which are not a standard item. Where two are fitted only one needs to fulfil the function **on each lock**. They may be integral with the steering mechanism.

If carrying out a steering full lock check with the wheels raised; any steering component, road wheel or tyre fouls any part of the vehicle when the vehicle is raised but does not foul any of these items when the vehicle is on the ground under normal running conditions, this is not a RfF.

Vehicles with independent front suspension should be checked with the suspension in the normal running position.

Common means of acceptable locking devices are:

Anti-rattle washers, split pins, lock wire, spring washers, nyloc nuts, liquid locking compounds and self locking castle type nuts.

If vehicles have their self steered axles welded in the straight ahead position please contact T&SS Swansea.

If a plain flat washer is used with a spring washer the locking action of the spring washer becomes ineffective.

**54 Steering
Application**

Visually check for axial and lateral movement of all ball joints. Where a ball joint is fitted with a spring to take up such movement, the compression of the spring must not be mistaken for excessive wear. If excessive wear is suspected check by using hand pressure.

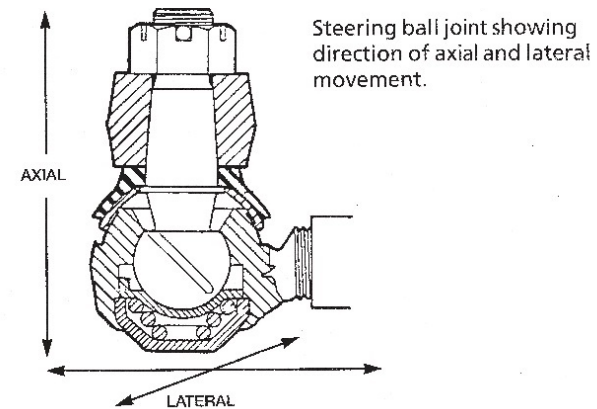

An increasing number of vehicles are now fitted with different types of ball joint, spring loaded or rubber mounted type each having different wear limits (some vehicle may be fitted with both types of joint). The rubber mounted type has a smaller wear limit than the spring loaded type.

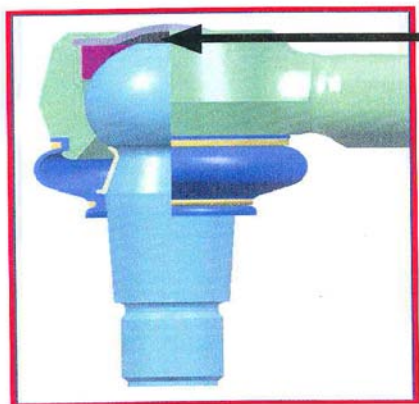

Rubber mounted type

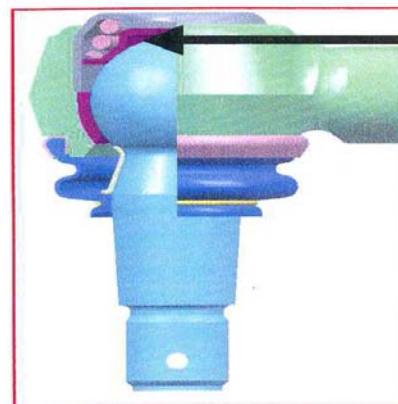

Spring loaded type

Certain ball joints are designed only to swivel fore and aft and not side to side (front drag link ball joints only, fitted on Volvo FE range and Post 2006 Renault Magnum Dxi, Premium Dxi and Kerax Dxi). In an attempt to swivel the joint you may hear a knocking sound this is normal as this is the device to stop it swivelling. The only wear limits that should be taken into account for the annual test is axial movement. Where lateral movement is evident in the ball joint it must be confirmed that axial movement in excess of 2mm exists before failure is justified.

Other manufacturers with conventional ball joints have also stated that axial movement up to 2mm is acceptable.

Heavy Goods Vehicle Inspection Manual

54 Steering	
Method of Inspection	Reason for Failure
<p>1. Check all types of Power steering for:</p> <ul style="list-style-type: none"> a. correct operation. b. presence and completeness. c. air or fluid leaks. d. hydraulic fluid level. e. pump security and any drive system for presence and condition. f. condition of pipes and hoses, and for fouling of other parts of the vehicle. g. condition of ram and/or ram body anchorage, free play at ram anchorage. h. free play between ball and valve i. cables damaged, excessively corroded. j. inappropriate repair or modification. k. malfunction Indicator lamp does not indicate a fault. 	<p>1. Power steering:</p> <ul style="list-style-type: none"> *a. not working correctly. b. removed or disconnected when a standard fitment. c. with an air/fluid leak from any part of the system. d. reservoir is empty or fluid is below minimum level. e. pump insecure or its drive system missing or defective. f. pipe or hose excessively corroded, damaged, bulging or fouling other parts of the vehicle. g. with a cracked or damaged ram and/or ram body anchorage, any excessive free play at ram anchorage. h. with excessive free play between ball and valve to the extent that separation is likely. i. with cables damaged, excessively corroded. j. with an inappropriate repair or modification. k. malfunction indicator lamp indicates a fault.

Heavy Goods Vehicle Inspection Manual

54 Steering	
Method of Inspection	Reason for Failure
<p>2. Check Steering:</p> <ul style="list-style-type: none"> a. ball pin shank for security. b. neck of a ball pin, for condition. c. track rod or drag link end for security. d. joints for abnormal movement. e. sector shaft and drop arm has no movement. f. pivot point condition (e.g. an intermediate drop arm). g. parts fixed to the chassis for security (e.g. an intermediate drop arm, pivot housing, steering box, ram arm). h. arm and fixings has no movement between them. i. components for fractures, cracks or damage, wear, misalignment and deformation. j. retaining or locking device for installation and security. k. lock stops for installation, security and function. l. components have not been modified and or repaired inappropriately by welding or showing signs of excessive heat being applied. 	<p>2. Steering with:</p> <ul style="list-style-type: none"> *a. a ball pin shank loose. b. a sharp or deep groove at the neck of a ball pin. c. a track rod or drag link end insecure. d. any abnormal movement in a joint. e. movement between sector shaft and drop arm. f. excessive wear in a pivot point (e.g. an intermediate drop arm). g. a part fixed to the chassis insecure (e.g. an intermediate drop arm, pivot housing, steering box, ram arm). h. movement between a steering arm and its fixings. *i a component fractured or so cracked, damaged, misaligned, deformed or so worn that it is likely to fail. *j a retaining or locking device ineffective, not fitted or insecure. k. a steering lock stop missing, insecure or not fulfilling its function. l. a component inappropriately modified, repaired by welding and or showing signs of excessive heat being applied.

54 Steering

Method of Inspection	Reason for Failure
<p>2. Check Steering (continued):</p> <ul style="list-style-type: none"> m. component, road wheels or tyres are not fouling any part of the vehicle at its normal ride height. n. track rod is not excessively deformed. o. is smooth and free in operation. p. lift and end float of a sector shaft. q. rack for wear. r. rack housing for movement in its bushes. s. rack gaiters are complete, undamaged and not displaced. t. ball joint dust covers for presence and condition. u. for leaks. v. gear casing for fractures. 	<p>2. Steering with(continued):</p> <ul style="list-style-type: none"> m. any steering component, road wheel or tyre fouling any part of the vehicle. n. track rod excessively deformed. *o roughness or undue stiffness in the operation of the steering. p. excessive lift or end float of a sector shaft. q. excessive wear in the steering rack. r. excessive movement of rack housing in mounting bushes. s. a rack gaiter (if rack originally fitted with gaiters) split, damaged, missing or displaced. t. a ball joint cover missing, insecure, excessively damaged or severely deteriorated to the extent that it would no longer prevent the ingress of dirt etc. u. leak of oil. v. gear casing fractured.

57 Transmission

Application

This inspection applies to all vehicles including Hybrid Electric Vehicles (HEVs) and to trailers with driven axles.

Vehicles must be in neutral gear and with any transmission brake released during this inspection.

The presenter should be advised if any shaft or carrier locking device is missing or ineffective.

Failure for excessive wear of a universal joint is only justified when radial movement indicates that needle roller bearings are missing from one or more cups.

Transmission shafts include those shafts that transmit drive for HEVs.

Propeller shaft spline wear is not a Reason for Failure.

A power take off prop shaft universal joint is not subject to this inspection.

Heavy Goods Vehicle Inspection Manual

57 Transmission	
Method of Inspection	Reason for Failure
<p>1. Check all vehicles for:</p> <ul style="list-style-type: none"> a. propshaft flange bolt(s) for security and presence. b. condition of any flange and its security. c. condition of a shaft bearing. d. condition of a bearing housing and its security. e. condition of universal joints. f. condition of flexible couplings. g. condition of shaft(s). h. condition of a bearing housing flexible mounting. i. transmission shaft(s) fouling another component. <p>2. Check front wheel drive shafts for:</p> <ul style="list-style-type: none"> a. condition and security of constant velocity or universal joints. b. condition, of the flexible coupling. c. condition presence and security of gaiters protecting the constant velocity joint. 	<p>1. All vehicles with:</p> <ul style="list-style-type: none"> a. a loose or missing propshaft flange bolt. b. any flange cracked or loose. c. excessive wear in a shaft bearing. d. a bearing housing insecure, cracked or fractured. e. excessive wear in a universal joint. f. deterioration of a flexible coupling such that failure is imminent. g. a seriously damaged or cracked shaft. h. deterioration of a bearing housing flexible mounting such that failure is imminent. i. evidence of a transmission shaft fouling on another component. <p>2. Front wheel drive shafts with:</p> <ul style="list-style-type: none"> a. a constant velocity or universal joint excessively worn or insecure. b. a flexible coupling severely cracked, softened or breaking up such that failure is imminent. c. a constant velocity gaiter missing, insecure, excessively damaged or severely deteriorated to the extent that it would no longer prevent the ingress of dirt etc.

58 Additional Braking Devices

Application

This inspection applies to vehicles where a device is fitted or required.

Air leaks for operating mechanisms of hydraulic retarders or exhaust brakes should be tested under item 59 and only fail if the leak is affecting the braking system.

Any inoperative device will be a reason for failure irrespective of whether it is mandatory or not.

If the device has been removed and it is mandatory this will be a reason for failure, if the device is not mandatory the operator should be informed to complete a VTG10 notifiable alteration form. Where an exhaust brake operating cylinder and lever are completely removed, the housing containing the butterfly may be retained with the butterfly fixed in the open position.

The check of operation is made by visual assessment to establish the likelihood of correct fitment and function, rather than to see actual operation. Failure is justified only when it is obvious that a device is inoperative i.e. a disconnected linkage.

Hybrid Electric Vehicles (HEVs) where the power train equipment acts as a regenerative brake, the unit(s) should be inspected as if it is an additional braking device. This will be marked on the technical record.

Method of Inspection	Reason for Failure
<p>1. Check additional braking devices for:</p> <ul style="list-style-type: none"> a. presence when known to be a mandatory fitment. b. operation, condition completeness, and security. c. security and condition of wiring. 	<p>1. An additional braking device:</p> <ul style="list-style-type: none"> a. missing when known to be a mandatory item. b. inoperative, damaged, component missing, or insecure. c. wiring insecure or damaged.

59 Brake Systems and Components

Application

This inspection applies to all vehicles.

Automatic slack adjusters must be fitted to motor vehicles first used from and trailers manufactured from 1 April 1995.

A rod or lever reduced by more than one third of its original diameter is considered a failure.

A pipe with its wall thickness reduced by more than one third of its original thickness is considered a failure.

Cables with less than 10% of the wires fractured are not regarded as a reason for failure unless there is bunching, or likelihood of bunching, where the cable enters an outer cable, guide or sleeve.

A hose should be rejected for surface cracking or damage by chafing only if the reinforcement is visible.

Repairs to metal air brake pipes by sleeving are acceptable, providing the repair appears to be good and sound. A pipe repaired in-situ by brazing is not considered acceptable. Repairs to hydraulic brake pipes are not acceptable. Compression joints of the type using separate ferrules are not considered suitable for joints on hydraulic pressure lines.

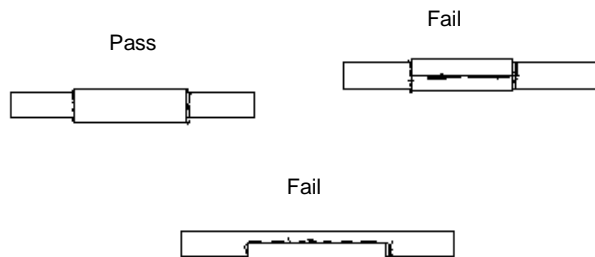

Guidance on sleeved repairs of metal brake pipes (sleeving is not acceptable on plastic brake pipes).

The air pipe between the compressor and the reservoir is to be taken as a brake pipe.

Lever slack adjusters; up to a total of 9.5mm radial movement at a radius of 150mm is considered acceptable within the slack adjuster and between the slack adjuster and cam cross shaft. Slack adjusters must have a secure fastening to the cross shaft including a locking device.

Slack adjusters with different lever lengths on the same axle are not a reason for failure, but the presenter needs to be informed to complete a VTG10 notifiable alteration form.

59 Brake Systems and Components

Application

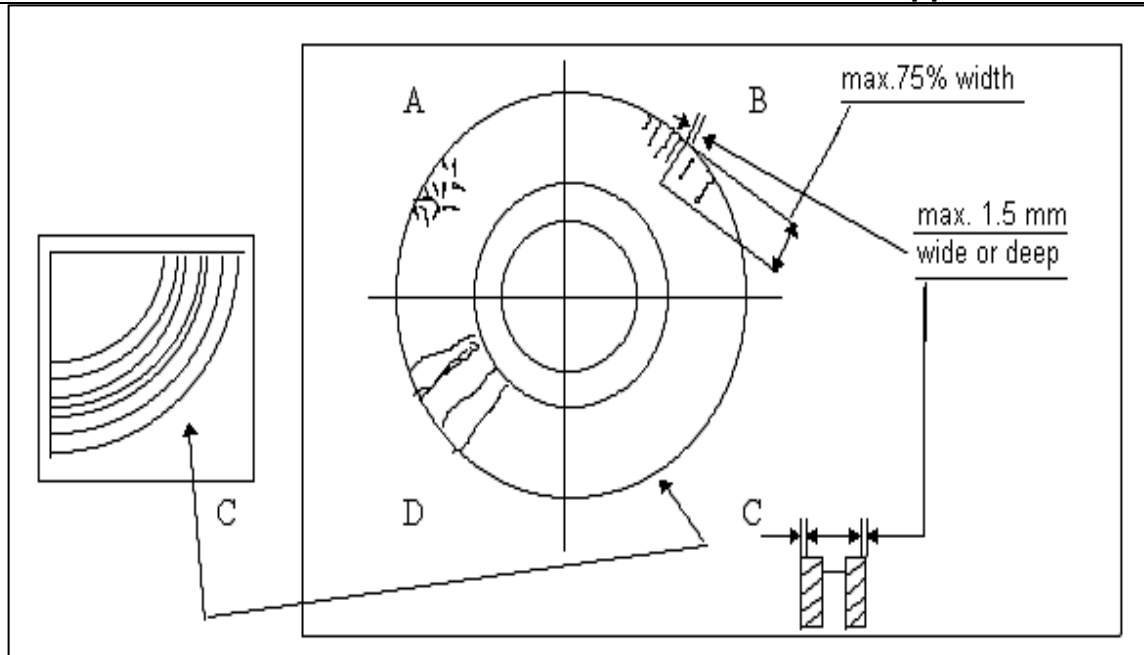

Disc Brakes

The diagram to the left shows the types of damage which are likely to be found on brake discs and gives guidance on how much damage is acceptable before failing the vehicle. This should be a visual assessment.

- A. Interlinked cracks or surface crazing = acceptable
- B. Cracks running towards hub centre up to max. 75% of the width of the friction surface, and a maximum of 1.5mm wide or deep = acceptable
- C. Unevenness in the disc surfaces less than 1.5 mm = acceptable
- D. Cracks running from edge to centre = not acceptable

The above diagram is for reference only.

Damp patches around valves or adjacent components are not a Reason for Failure. Only where there is evidence of heavy discharge of oil from the valve at the time of test should there be a failure.

To check the condition of brake pipes including the output side of the compressor, valves, hydraulic master & wheel cylinders it will be necessary to ask the driver to pressurise the braking systems. There is no requirement for a specific check on the operation of all valves, however where it is obvious that a valve is malfunctioning during any stage of the test, this is a Reason for Failure.

When assessing the significance of leaks, it should be remembered that certain pneumatic components are subject to leakage to some degree.

59 Brake Systems and Components

Application

Vented master cylinders as fitted in particular to some Bedford vehicles may be subject to some dampness around the vent, due to fluid in the bores of the cylinder used to lubricate the piston seals, this should not be treated as a defect.

Quick Release Valves/Spring Brake Systems; On trailers fitted with spring brake systems a controlled discharge of air may occur from the quick release valve when the service brake is applied with the spring brakes in the off position, this is acceptable and should not be treated as a defect.

The following vehicle/trailer types require an adapter to be fitted to inspect the trailer secondary brake operation:

- Two line drawing vehicles coupled to three line trailers.
- Three line drawing vehicles with no separate secondary control coupled to three line trailers.

The following procedure should be carried out:

- Supply a suitable adapter and request the driver to connect the tractor/drawing vehicle service line to the trailer secondary line and request the driver to operate the brake (If spring brake actuators are fitted to the vehicle/trailer inspect the components of this system with the park brake in the “off” position).
- Instruct the driver to remove the adapter and reconnect the brake lines. Check the reconnection by instructing the driver to apply the footbrake and note the operation.

If the secondary brake (blue line) has been disconnected without approval, this is not a failure. The presenter must be advised to submit a VTG10 Notifiable Alteration.

Care should be taken when inspecting BPW axles as the brake calliper may have 6 holes and only 5 bolts fitted.

Two line trailers are not fitted with secondary brakes. Some drawing vehicles where the nominated secondary brake is the split service brake do not operate the trailer brakes when the hand park brake control is applied. This is not a reason for failure'.

Reservoirs can be repaired by welding the term reservoir includes accumulators and other types of vacuum & pressure vessels.

The hydraulic fluid level check only applies to readily visible reservoirs which can be checked without removing the reservoir cap.

59 Brake Systems and Components

Application

It is not a requirement for Load Sensing Valves (LSV) to be moved manually to check their operation. In most cases a slight movement can be detected when the service brake is applied which is sufficient evidence that the LSV is operating. Only in the minority of cases where, in the opinion of the tester, the LSV appears seized and it is the type of valve that can be checked easily by hand without the possibility of causing damage should this be carried out.

Pre 1995 vehicles which were fitted with automatic brake slack adjusters that have been removed and replaced with manual ones. If the automatic slack adjuster brackets have not been removed and are not being used this is acceptable.

If a brake chamber is attached to a chassis cross member and the cross member is fractured and parted at one end this is a reason for failure.

The following list gives guidance on when trailers manufactured before October 1 1982 may be required to have a load sensing valve or ABS as a mandatory fitment.

1. Pre 1982 and post 1968 semi or draw bar trailer with three line braking (service yellow line, secondary/auxiliary blue line and emergency red line) LSV and ABS are not required.
2. Pre 1968 trailer with any number of brake lines LSV or ABS are not required.
3. A post 1968 semi-trailer with a gross weight over 3500kg and converted to two line braking (type approved braking system) LSV or ABS required.
4. A post 1968 draw bar trailer with axle/s weight over 3500kg and converted to two line braking (type approved braking system) LSV or ABS required.
5. A trailer of any age with two brake lines and with an unladen weight 60% or less of the gross weight and can be demonstrate by calculations that the brakes comply with the requirements of the braking directive, LSV or ABS are not required.
6. Foreign trailers pre 1982 with two line brakes LSV or ABS may be required.
7. If you are not sure if a trailer is required to have LSV or ABS fitted contact Technical Services Swansea.

Missing or illegible LSV plate only applies to the following;

- Trailers first used on or after 29th October 2013.
- Trucks first used on or after 29th October 2014.

Some manufacturers use different sizes of brake chambers in addition to the standard sizes that have been used for many years and some manufacturers use common castings. For example a Type 22 can be made from a Type 24 casting. To avoid confusion the manufacturer fits a tag to confirm the chamber size. The first two digits are the service chamber size, if it is a spring brake the second two digits are the parking brake chamber size. This is an acceptable method of identifying chamber sizes.

59 Brake Systems and Components

Method of Inspection	Reason for Failure
<p>1. Check brake rods, clevis joints, linkages, relays, levers, pins, pivots, slack adjusters or cables for:</p> <ul style="list-style-type: none"> a. condition. b. correct adjustment. c. a locking device which is effective, secure and present. d. the condition and completeness of a brake cable. e. condition of cable guide. f. the condition fitment, completeness, security, and operation of components of an automatic slack adjuster. g. mandatory automatic slack adjuster fitted. h. the travel of a brake fitted with an automatic slack adjuster, compare the travel of the automatic slack adjusters across the same axle, the slack adjuster lever returns fully when the brakes are released. 	<p>1. A brake rod, clevis joint, linkage, relay, lever, pin, pivot, slack adjuster or cable:</p> <ul style="list-style-type: none"> *a. seriously weakened by excessive wear, corrosion, damage or reduced in diameter by more than the prescribed limit. *b. with abnormal movement indicating incorrect adjustment , or excessive radial free play. *c. with an ineffective, insecure or missing locking device. *d. a brake cable knotted, or with more wires broken than permitted by the specified standard. *e. cable guide is defective. *f. automatic slack adjuster component missing, disconnected, insecure, distorted, fractured or inoperative. *g. mandatory automatic slack adjuster not fitted. *h. a brake fitted with an automatic slack adjuster exceeding two- thirds of the travel of the brake actuator, or obviously having a different travel from another brake on the same axle, or not returning fully when brakes are released.

59 Brake Systems and Components

Method of Inspection	Reason for Failure
<p>2. Check brake pipes and flexible hoses for:</p> <ul style="list-style-type: none"> a. clearance of moving parts. b. condition. c. adequately clipped or otherwise adequately supported. d. repairs and suitable joint fittings. e. non-metallic pipe(s) condition. 	<p>2. Brake pipes and flexible hoses:</p> <ul style="list-style-type: none"> *a. fouled by moving parts. *b. excessively chafed, cracked with reinforcement cords exposed, excessively corroded, deteriorated, damaged, leaking, bulging, kinked, stretched or twisted. *c. inadequately clipped or otherwise inadequately supported. *d. inadequately repaired or with unsuitable joint fittings. *e. non-metallic pipe(s) exposed to excessive heat.
<p>3. Check brake drums, back plates & shoes, discs, callipers & pads including friction material for:</p> <ul style="list-style-type: none"> a. security and condition. b. brake back plate or calliper security bolt(s) secure and complete. c. brake lining(s) or pad(s) are secure and not less than 1.5mm thick at any one point. d. no restriction with the movement of a brake component. 	<p>3. Brake drums, back plates & shoes, discs, callipers & pads including friction material with:</p> <ul style="list-style-type: none"> *a. a brake back plate, disc or drum in such a condition that it is seriously weakened or insecure. *b. a brake back plate or calliper securing bolt loose or missing. *c. a brake lining or pad insecure or less than 1.5mm thick at any point. *d. restricted movement of a brake component.

59 Brake Systems and Components

Method of Inspection	Reason for Failure
<p>4. Check reservoirs for:</p> <ul style="list-style-type: none"> a. security, condition and leaks. b. damage. c. the condition of the securing strap. d. presence. <p>5. Check air actuators, hydraulic master & wheel cylinders, valves and servos for:</p> <ul style="list-style-type: none"> a. operation. b. security. c. condition. d. presence and security of locking devices. e. travel of operating mechanism. f. presence of a cap is fitted to a hydraulic master cylinder reservoir. g. sufficient brake fluid. h. fluid level device. 	<p>4. Reservoir:</p> <ul style="list-style-type: none"> *a. insecure, excessively corroded, or leaking. *b. with dents that reduce the capacity or with angled dents. *c. with a securing strap fractured, cracked, excessively corroded or chafing on the reservoir or other mounting. *d. missing where it is known to be a standard fitting. <p>5. Air actuators, hydraulic master & wheel cylinders, valves and servos:</p> <ul style="list-style-type: none"> *a. defective in operation. *b. insecure. *c. leaking air or fluid, fractured, cracked, excessively damaged or corroded. *d. with a locking device missing or insecure. *e. with excessive travel of operating mechanism indicating a need for adjustment. *f. with a cap missing from a hydraulic master cylinder. *g. fluid below minimum level or level warning device activated. *h. fluid level warning device defective.

59 Brake Systems and Components

Method of Inspection	Reason for Failure
<p>5. Check air actuators, hydraulic master & wheel cylinders, valves and servos for (continued):</p> <ul style="list-style-type: none"> i. a discharge of oil. j. presence and condition of a load sensing valve, where it is known to be a standard fitment. k. condition, movement and adjustment of a load sensing valve. l. dust cover presence and condition (only applicable to hydraulic brake actuators). <p>6. Check the load sensing valve data plate for:</p> <ul style="list-style-type: none"> a. presence. b. legibility. <p>7. Where an air compressor is belt driven, check the drive for:</p> <ul style="list-style-type: none"> a. fitment of a drive belt, its condition and adjustment. b. security of the pulley, its condition and presence. <p>8. Check trailer Secondary Brake for operation.</p>	<p>5. Air actuators, hydraulic master & wheel cylinders, valves and servos (continued):</p> <ul style="list-style-type: none"> *i. with a valve with excessive discharge of oil. *j. a load sensing valve removed or disconnected when it is known to be a standard fitment. *k. a load sensing valve obviously seized or restricted in its free movement, linkage or brackets cracked, defective or out of adjustment. *l. hydraulic brake actuator dust cover, missing, insecure, excessively damaged or deteriorated to the extent that it would no longer prevent the ingress of dirt etc. <p>6. A load sensing data plate:</p> <ul style="list-style-type: none"> *a. missing. *b. illegible. <p>7. Air Compressor Drive:</p> <ul style="list-style-type: none"> *a. a drive belt missing, badly deteriorated and/ or so loose that it is likely to slip. *b. a compressor drive pulley loose, cracked or missing. <p>*8. Trailer Secondary Brake defective in operation.</p>

62 Markers and Reflectors

Application

Rear Markings

This inspection applies to the vehicles and trailers listed below which must be fitted with rear markers. They are not required with rear conspicuity markings but may be incorporated into the conspicuity markings (See pages 6 & 7). The type of marking which is acceptable is shown in the table below. The type numbers refer to diagrams (1 to 13) on the following page. Rear conspicuity marking is an acceptable alternative to marker boards, if fitted it must comply with the conspicuity requirements (see pages 6 & 7).

Motor vehicles with a maximum gross weight exceeding 7500kg (not articulated tractors and vehicles constructed or adapted for transporting two or more boats, vehicles or vehicle bodies).

Overall length	Acceptable type of markings for vehicle first used before 1 April 1996	Acceptable markings for vehicle first used from 1 April 1996
13m or less	1,2,3,6,7,8 or 9	6,7,8 or 9
more than 13m	4,5,10,11,12 or 13	10,11,12 or 13

Trailers with a maximum gross weight exceeding 3500kg (not trailers constructed or adapted for transporting two or more boats, vehicles or vehicle bodies).

Overall length of combination	Acceptable type of markings for trailers manufactured before 1 October 1995	Acceptable markings for trailers manufactured from 1 October 1995
11m or less	1,2,3,6,7,8 or 9	6,7,8 or 9
more than 11m but not more than 13m	Any type shown in the diagrams	6,7,8,9,10,11,12 or 13
more than 13m	4,5,10,11,12 or 13	10,11,12 or 13

62 Markers and Reflectors

Application

They must be fitted with the lower edge between 400mm and 1700mm from the ground.

A rear marker must not be more than 10% obliterated or obstructed.

If the rear marker boards chevrons are fitted the opposite way around than shown below this is not a RfF.

When a demountable fork lift is carried on the rear of a vehicle/trailer, the fork lift is not included into the overall length of the vehicle/trailer to establish what the correct type of marking fitted is. This would also apply to refuse vehicles with bin lifting equipment fitted to the rear of the vehicle.

Rear markings on a retractable rear under-run device are not a reason for failure if the vehicle is presented towing a trailer and the vehicle rear markings are not visible.

Acceptable approval marks for rear marker boards are either BSAU152 (diagrams 1 - 5), 'E' or 'e' (diagrams 6 - 13).

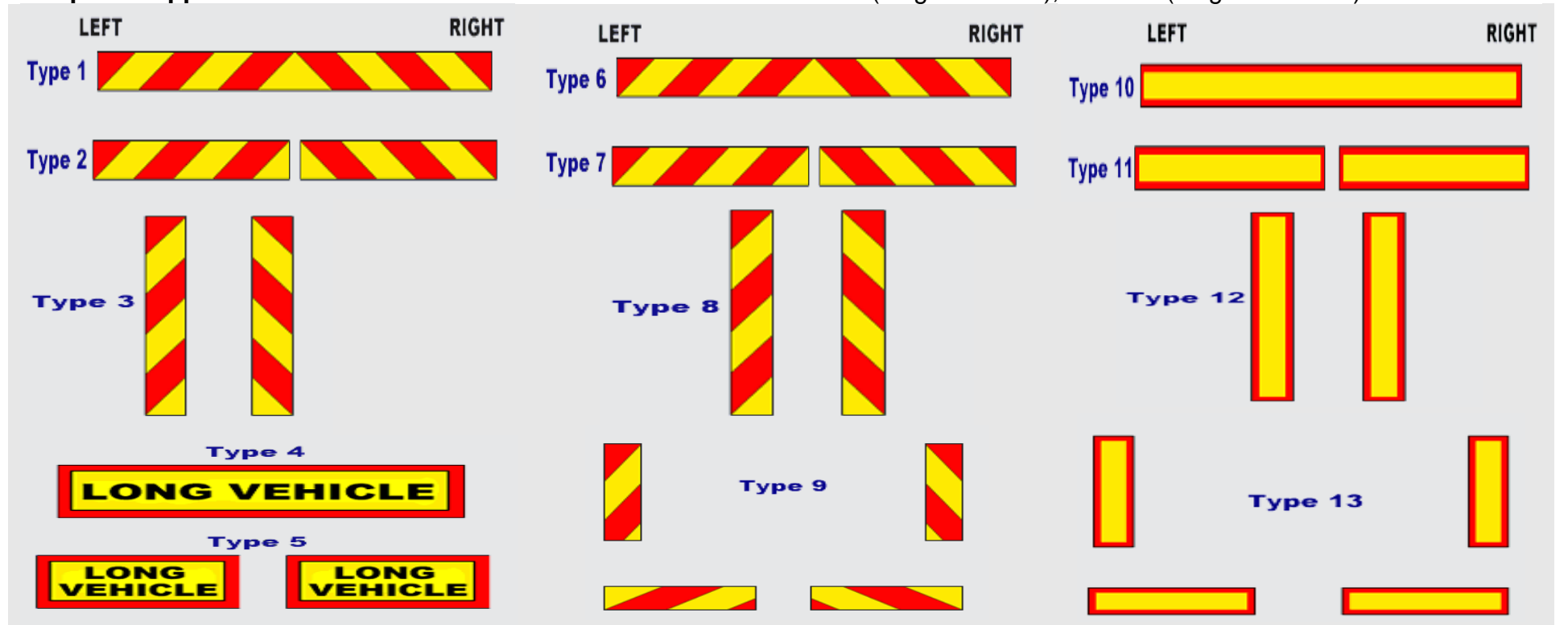

62 Markers and Reflectors

Application

Reflectors

This inspection applies to all motor vehicles and trailers but only obligatory reflectors are to be checked.

- Every motor vehicle and trailer requires 2 red reflectors facing to the rear.
- Trailers manufactured from 1 October 1990 require two white reflectors facing to the front.

The inspection does not include a check that the reflectors have the appropriate approval mark. Reflective plates or tape are not acceptable as a substitute for a reflector. The check for position should be visual and only vehicles with reflectors and markings obviously out of position should be failed for this reason.

Front Reflectors [trailers only]

The maximum height from the ground is 900mm, if this is impractical it can be 1500mm.

White front reflectors must be fitted to the front of each section of a combination trailer.

Rear Reflectors

The maximum height from the ground is 900mm. There are some exceptions:

- If 900mm is impractical it can be 1500mm.
- For vehicles used before 1 April 1986 and trailers manufactured before 1 October 1985 the maximum height is 1525mm.

Trailers must be fitted with triangular (rear) reflectors, these are not acceptable on motor vehicles and must be failed using RfF 1f.

Side reflectors

This inspection applies to a motor vehicle.

- first used before 1 April 1986 with an overall length of more than 8m first used from 1 April 1986 with an overall length of more than 6m.
- This inspection applies to trailers with an overall length of more than 5m excluding any drawbar.

They must be positioned as shown in one of the two diagrams on the following page. They must be amber in colour unless within 1 m of the rear of the vehicle or trailer when they may be red.

If less than 50% of any reflector is visible, this is a reason for failure.

62 Markers and Reflectors

Application

Side Reflector Positional Requirements

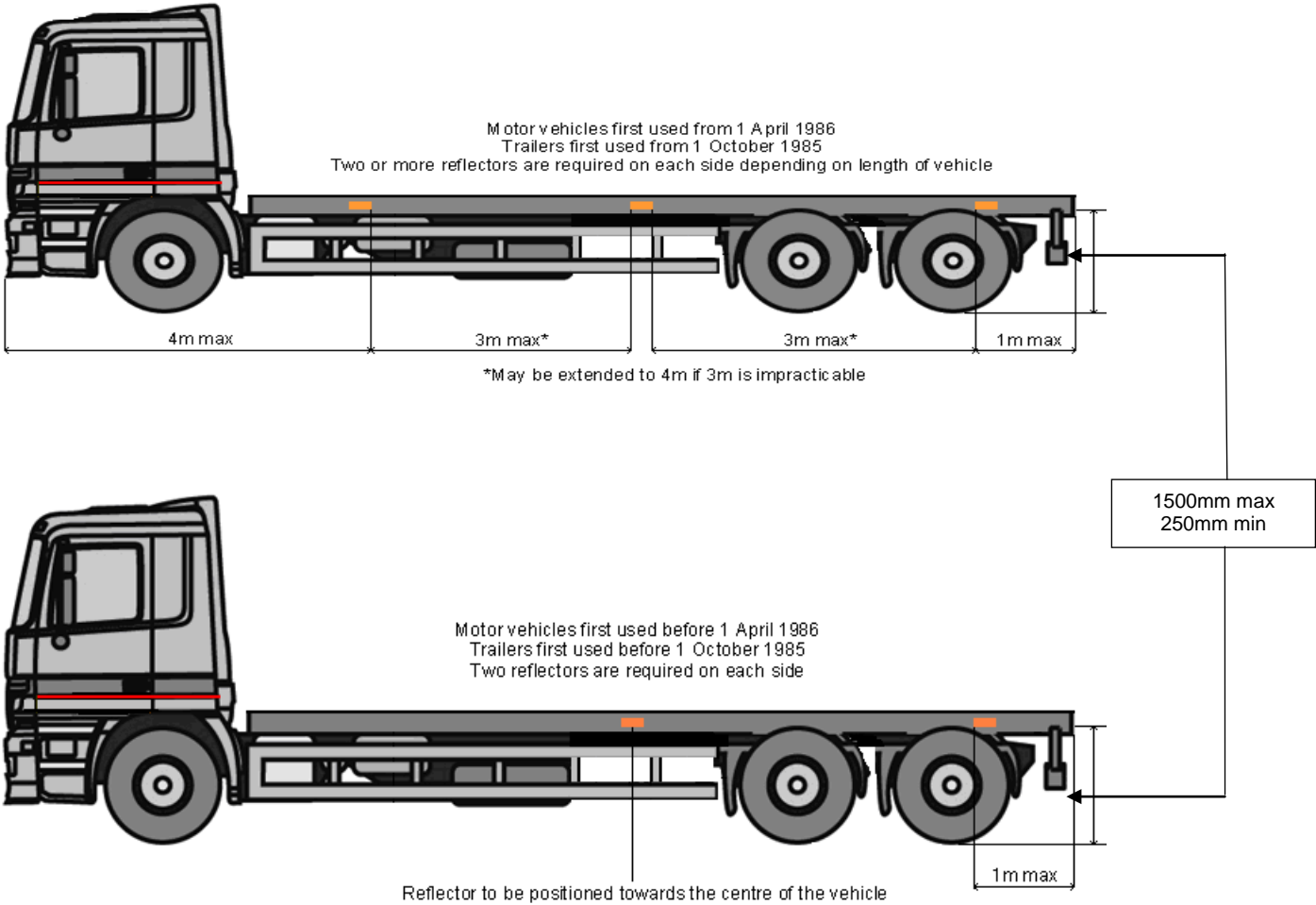

62 Markers and Reflectors

Application

Conspicuity Markings

This inspection applies to Goods vehicles with a gross weight exceeding 7500kg first used on or after 10 July 2011 and Trailers with a gross weight exceeding 3500kg first used on or after 1 January 2012:

Exemptions:

- Chassis cabs, incomplete vehicles and articulated tractors for semi-trailers
- Vehicles and trailers not exceeding 6 metres overall length (these are exempt the white or yellow side markings)
- Vehicles and trailers not exceeding 2.1 metres overall width (these are exempt the red or yellow rear markings)

Configurations (see pages 7 & 9)

Markings should be continuous but may be broken, staggered or set back. They are considered continuous if gaps are less than 50% of the length of the shortest adjacent element (if this is impractical a maximum gap of 1000mm is acceptable).

Vehicles and trailers may be presented with various markings, the minimum requirement (for annual test) is a line marking intended to indicate the horizontal dimensions of a vehicle by a continuous line.

Due to design characteristics it may not be possible for some vehicles to comply with all of the requirements.

The diagrams on pages 9 to 12 are only possible examples of variations.

Vehicles and trailers which have a chassis designed for demountable bodies should, ideally, be treated as skeletal. However they may be presented for test with a body fitted which has conspicuity markings instead of the chassis. Provided the markings comply with the requirements this is acceptable though the presenter should be advised that the vehicle or trailer would not meet the requirements if used without an appropriately marked body.

62 Markers and Reflectors

Application

Rear conspicuity markings must:

- not be fitted within 200mm of a mandatory stop lamp.
- be coloured either red or yellow
and
- be at least 70% of the vehicle width and extend as close as practicable to the edges of the vehicle or trailer.
- position the lowest edge between 250mm and 1500mm from the ground. If 1500mm is not practicable this can be increased to 2500mm.

(See Page 7)

62 Markers and Reflectors

Application

Rear Conspicuity Marking Requirements

Horizontal markings must be at least 70% of the vehicle width and extend as close as practicable to the edges of the vehicle or trailer

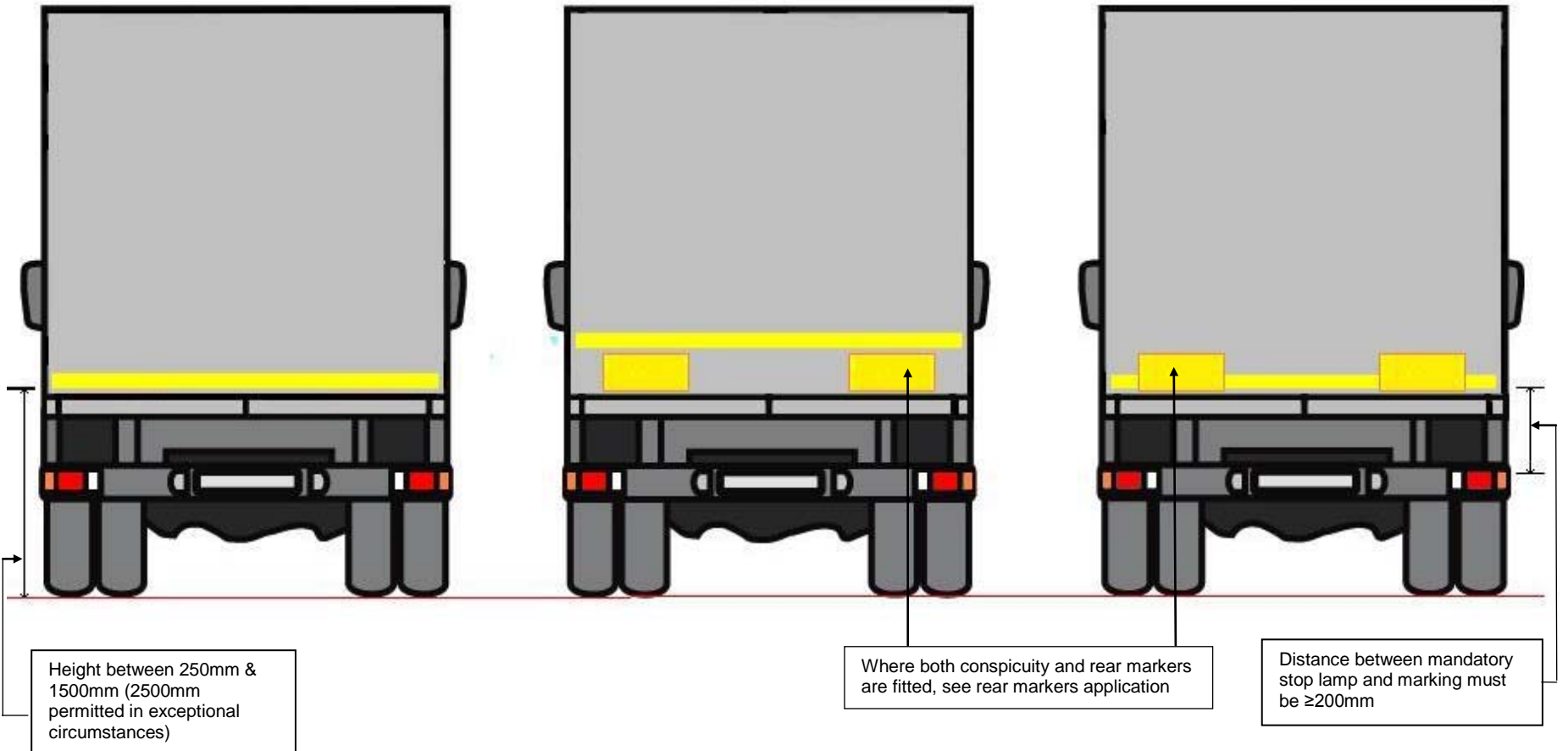

62 Markings and Reflectors

Application

Side Conspicuity markings must:

- extend to within 600mm of each end of the vehicle/trailer (or for articulated vehicles, the trailer).
- for rigid vehicles be at least 70% of the vehicle length measured from 2.4m from the extreme front of the vehicle . Where side markings on a rigid vehicle meet the 70% requirement of the vehicle length on the body alone the cab must still be marked within 600mm of the front of the vehicle with a minimum marking size of 50 mm high by 50mm wide. Where this requirement is met any gaps between the cab markings and body markings must be disregarded.
- for semi and drawbar trailers be at least 70% of the trailer length.
- be coloured white or yellow.
- position the lowest edge between 250mm and 1500mm from the ground. If 1500mm is not practicable this can be increased to 2500mm.

(See Page 9)

Note: As an alternative cab marking from using a 50mm X 50mm conspicuity marking within 600mm of the cab front, the cab may be marked using side reflectors with a minimum spacing of 600mm to within 600mm from the front of the cab.

62 Markings and Reflectors

Application

Side Conspicuity Marking Requirements

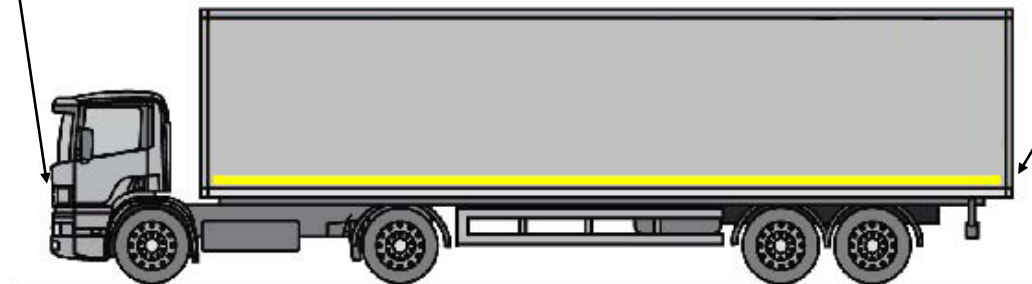
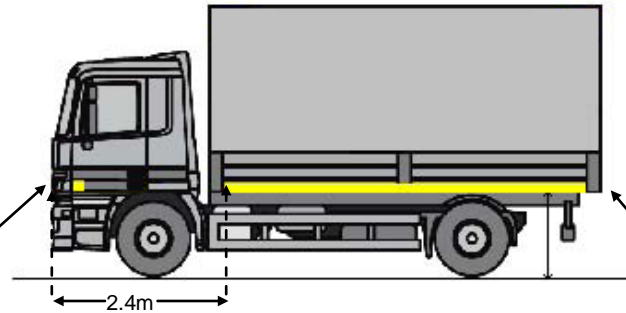

Rigid vehicle cabs must be marked within 600mm of the front end. Tractor units for semi trailers do not need to be marked.

- Total cumulative length \geq 70% of vehicle length (measured from 2.4m from the extreme front of the vehicle)
- For trailers total cumulative length will be the full trailer length
- Height between 250mm & 1500mm. (2500mm permitted in exceptional circumstances)
- Markings as close as practical to the ends of vehicle and not more than 600mm

62 Markers and Reflectors

Application

Car Transporter

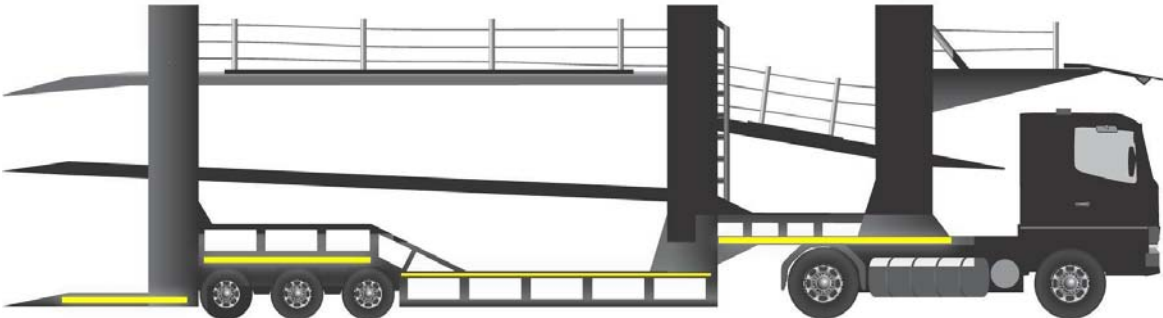

Concrete Mixer

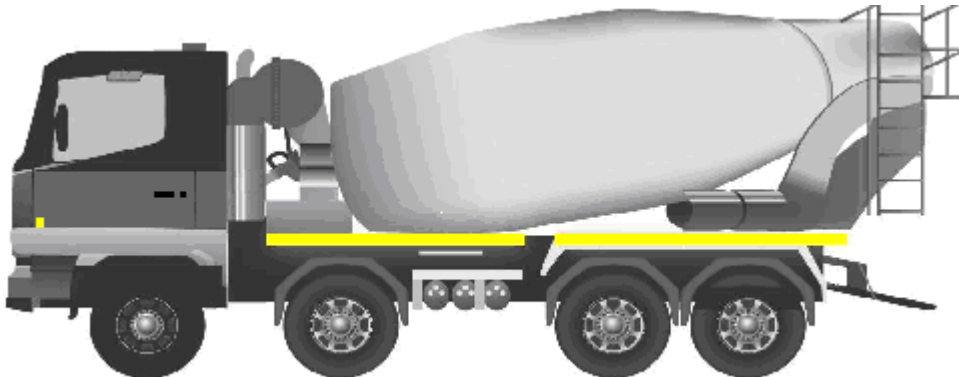

62 Markers and Reflectors

Application

Skeletal

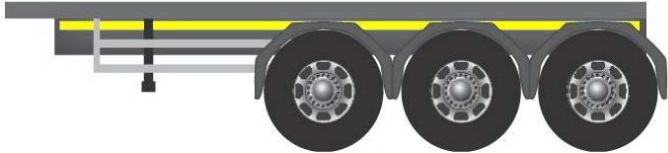
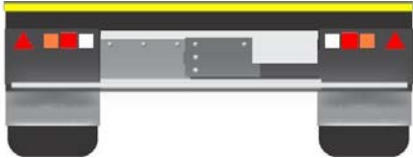

Skip Wagon

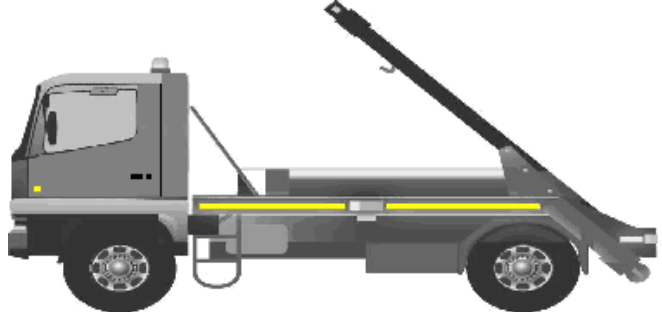

Where both conspicuity and rear markers are fitted, see rear markers application

Refuse Wagon



62 Markers and Reflectors

Application

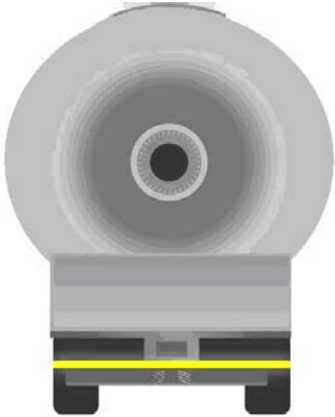
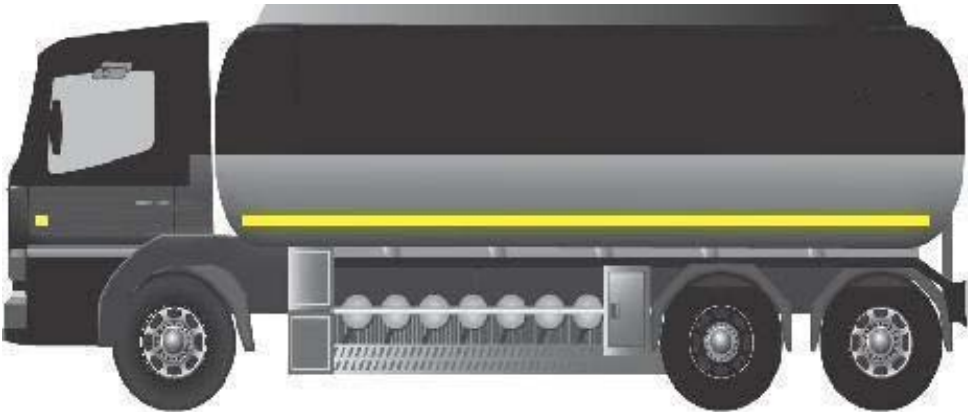

Tanker

Method of Inspection

Reason for Failure

- 1. Check reflectors, conspicuity markings, and/or rear markers are:
 - a. fitted.
 - b. correctly positioned.
 - c. secure.
 - d. clearly visible.
 - e. facing the appropriate direction.
 - f. of the correct type fitted.
 - g. clean and effective and their function is clear.
 - h. complete.
 - i. the appropriate colour.

- 1. Reflectors, conspicuity markings and/or rear markers:
 - a. missing.
 - b. incorrectly positioned.
 - c. insecure.
 - d. not clearly visible.
 - e. not facing to the appropriate direction.
 - f. of the incorrect type fitted.
 - g. so dirty or ineffective that its function is impaired.
 - h. broken, damaged or incomplete to the extent that the reflecting area is significantly reduced.
 - i. not of the appropriate colour.

63 Lamps

Application

The inspection of front position lamps, headlamps, rear position lamps and registration plate lamps applies to all the obligatory lamps fitted to vehicles and trailers.

Stop lamps

The inspection of stop lamps applies to any stop lamp fitted to vehicles and trailers.

End outline Marker Lamps

The inspection of end outline marker lamps applies to the obligatory marker lamps fitted to:

- vehicles first used from 1 April 1991.
- trailers manufactured from 1 October 1990.

and which in both cases are more than 2.1m wide.

End outline marker lamps are not required on vehicles designed to carry demountable bodies if the overall width without the body fitted is less than 2.1 m.

The front and the rear end out line markers lamps may be combined as for example on an articulated tractor.

The rear marker lamps on vehicles such as tippers and tankers and those designed to carry demountable bodies may be fitted at chassis level.

It is not acceptable for a position light to be used additionally as a marker lamp, a separate lamp must be fitted.

The end outline marker lamps fitted to the rear of a vehicle can also act as the rear most side marker lamp provided it is of the correct colour and position. It is not acceptable for a side marker lamp to operate as an outline marker lamp.

Front marker lamps are not required to be fitted to the front section of the rear half of a combination trailer.

Rear fog lamps

The inspection of rear fog lamps applies to any vehicle or trailer fitted with a rear fog lamp.

Rear fog lamps must be fitted to vehicles first used, and trailers manufactured from 1 April 1980.

The rear fog lamps are permitted to be reciprocally incorporated with the rear position lamps providing the positional requirements are met (when the fog lamp is switched on the rear position lamps intensity increases to become the fog lamp).

Fog lamps are not needed on modern trailers when drawn by old vehicles (see above for dates).

Inspection of non-obligatory rear fog lamps is restricted to a check of colour (RfF 1.d) and whether the operation of the brakes affects the fog lamp (RfF 1.g).

No more than two rear fog lamps may be fitted.

It is not a RfF if the vehicles rear fog lamp does not operate when a trailer is towed. However the electrical connections to the trailer must be disconnected to confirm that the rear fog lamp/s operate when the vehicle is not towing a trailer.

63 Lamps

Application

Headlamps

The plain looking covers fitted to some vehicle headlamps should be treated as a lens.

Main beam warning lamps are required on vehicles first used on or after 1 April 1986.

Side marker lamps

The inspection of side marker lamps applies to all obligatory side marker lamps fitted to vehicles and trailers.

Side marker lamps must be fitted to:

- vehicles with an overall length exceeding 6m first used from 1 April 1991
- trailers with an overall length exceeding 6m manufactured from 1 October 1990
- trailers with an overall length exceeding 9.15m manufactured before 1 October 1990

Two or more marker lamps must be fitted at each side to ensure that the following is complied with:

Maximum distance of the foremost marker lamp from the front of the vehicle or trailer, including any drawbar	4m
Maximum distance of the rearmost marker lamp from the rear of the vehicle or trailer	1m
Maximum distance between the light emitting surfaces of adjacent marker lamps	3m or if this is not practicable 4m

Vehicles first used before 1 April 1996 are exempt from the need to fit side marker lamps if they are fitted with all of the lighting and light signalling devices listed in items 1.5.7 to 1.5.20 of Annex 1 of Community Directive 76/756/EEC as amended. Motor vehicles which comply with these requirements will be fitted with a label showing a dipped headlamp and a percentage dip figure or/and a manual headlamp height adjuster control, readily accessible from the driver's seat and which operates both lamps simultaneously.

Rear registration plate lamps

The clear cover for the bulb is not a lens.

The registration plate lamp must be fitted in a position where it can illuminate the registration plate. A lamp fitted in a position where it cannot do this is not a registration plate lamp and this should be dealt with under RfF 1 (a).

63 Lamps

Application

Obscuration of lamps, provided at least 50% of a lamp is visible this is not a RfF.

Matched Pair means that the lamps emit light of the same colour and intensity and that both lamps are of the same size and are symmetrical to one another.

If more than one bulb or LED is fitted in the lamp at least 50% must work.

If two or more lamps are fitted and the aggregated illuminated area occupies 60% or more of the area of the smallest rectangle circumscribing the illuminated area this should be treated as one lamp.

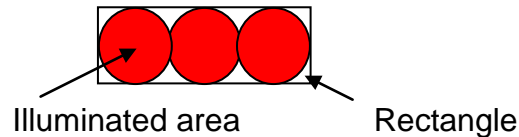

Vehicles with fork lifts fitted to the rear of the vehicle. If the fork lift has lights to replace the vehicles which may be obscured, the lights on the fork lift must comply with the annual test standards.

The check for position should be visual and only vehicles with lamps obviously out of position should be failed for this reason (not applicable to lamps fitted to rear under-run devices that fold underneath the load deck to accommodate the attachment of a trailer).

Before failing the operation of a lamp being affected by the operation of another lamp. The engine should be run to charge the electrical system.

Light that bleeds through from an adjacent lamp is acceptable provided the illuminated light lens does not change colour.

Gas discharge lamps, blue tint bulbs and lamps with neutral colour lenses are acceptable providing when lit the light emitted is white or; if it is a direction indicator is amber or in the case of a stop lamp red.

Normally plastic cable ties are not acceptable as the only means of securing a lamp or lamp lens however Crane Fruehauf have a side marker lamp arrangement which includes a cable tie as an integral part of the design to provide some flexibility and to avoid damage to the marker lights. This arrangement is acceptable on Crane Fruehauf trailers and on any other makes of vehicle or trailer where a similar lamp system is fitted.

Vehicles equipped with dim dip require the front position lamps to be checked for operation with the ignition switched off.

Heavy Goods Vehicle Inspection Manual

63 Lamps

Application

A summary of the main requirements for each type of lamp is shown below.

TYPE		DATE OF FIRST USE (MANUFACTURE FOR TRAILERS)	POSITION			COLOUR
			MAX DISTANCE FROM SIDE (MM)	MAX HEIGHT (MM)	MINIMUM HEIGHT (MM)	
Front Position Lamps	Motor Vehicles	From April 1986	400	1500 or if impracticable 2100	-	White or yellow if in a headlamp which shows yellow light
		Before April 1986	510	2300	-	
	Trailers	From October 1985	150	1500 or if impracticable 2100	-	White
		Before October 1985	510	2300	-	
Front End Outline Marker Lamp	Motor Vehicles	From April 1991	400	-	The top of the lamp shall be no lower than the top of the windscreen	White
	Trailers	From October 1990	400	-	As high as possible with regard to the lateral position, and the use for which the vehicle is constructed	
Dipped Beam Headlamp		From 1972 (refer to Lighting regulations for earlier vehicles)	400 Being a matched pair	1200	500	White or Yellow
Main Beam Headlamp		From 1931		-	-	White or Yellow
Rear Position Lamps	Motor Vehicles	From April 1986	400	1500 or if impracticable 2100	350	Red
	Trailers	From October 1985				
	Motor Vehicles	Before April 1986	800	2100	-	
	Trailers	Before October 1985				

Heavy Goods Vehicle Inspection Manual

63 Lamps
Application

A summary of the main requirements for each type of lamp (continued).

Rear End Outline Marker Lamps	Motor Vehicles	From April 1991	400	-	As high as possible with regard to the lateral position, and the use for which the vehicle is constructed	Red
	Trailers	From October 1990				
Stop Lamps		From 1971 (refer to Lighting regulations for earlier vehicles)	One on each side with a minimum separation distance of 400mm	1500 or if impracticable 2100	350	Red
Rear Registration Plate Lamp		All vehicles and trailers	-	-	-	White
Rear Fog Lamp	Motor vehicles and trailers	From April 1980	Where one lamp is fitted: On centre line or offside of vehicle.	1200	250	Red
Side Marker Lamps	Motor vehicles	1 April 1991	-	2300	-	Amber or red if within 1m of the rear of the vehicle.
	Trailers	1 October 1990	-	2300	-	Amber or red if within 1m of the rear of the trailer or if fitted to a trailer built before October 1990 exceeding 9.15m in length one side marker lamp on each side, positioned longitudinally such that no part of the light emitting surface is forward of, or more than 1530mm to the rear of, the centre point of the overall length of the trailer. The lamp may show a white light to the front and a red light to the rear, or alternatively amber.

Heavy Goods Vehicle Inspection Manual

63 Lamps	
Method of Inspection	Reason for Failure
<p>1. Check lamps for:</p> <ul style="list-style-type: none"> a. presence and security of an obligatory lamp. b. correct illumination and function. c. presence of the lens, its visibility, security and condition. d. showing a light of the right colour. e. correct position. f. a steady light when lightly tapped by hand. g. not being affected by the operation of any other lamp. <p>2. Check the fog lamp (in addition to the above):</p> <ul style="list-style-type: none"> a. fog lamp has a tell tale light fitted, working and visible to the driver. b. the number of rear fog lamps fitted. <p>3. Check the stop lamp (in addition to the above) for a steady red light when the brakes are applied and goes out when the brakes are released.</p>	<p>1. For all lamps:</p> <ul style="list-style-type: none"> *a. an obligatory lamp missing or insecure. *b. a lamp dim, due to dirt or internal deterioration, or not working. *c. a lens missing, obscured, insecure, or damaged so it is likely to fall apart. *d. not showing a light of the right colour. *e. incorrectly positioned. *f. flickers when lightly tapped by hand. *g. is affected by the operation of any other lamp. <p>2. Fog lamp:</p> <ul style="list-style-type: none"> a. tell-tale light not fitted, not working or cannot be seen by the driver. b. more than two rear fog lamps are fitted. <p>*3. Stop lamp does not show a steady red light when the brakes are applied, or does not go out when the brakes are released.</p>

63 Lamps	
Method of Inspection	Reason for Failure
<p>4. Check a headlamp (in addition to the above) for:</p> <ul style="list-style-type: none"> a. forming part of a matched pair. b. being positioned symmetrically in relation to the other lamp. c. a lamp of a matched pair showing a light of the same intensity and colour as the other. d. a main beam headlamp that can be switched off by the operation of one switch which at the same time leaves a pair of dipped beams. e. a main beam warning light illuminates when main beam is selected and extinguishes when dipped beam is selected. <p>5. Check the rear registration plate lamp (in addition to the above) does not throw direct light to the rear</p>	<p>4. Headlamp:</p> <ul style="list-style-type: none"> a. not forming part of a matched pair. b. not positioned symmetrically in relation to the other lamp. c. one of a matched pair does not show a light of the same intensity and colour as the other. d. a main beam headlamp cannot be switched off by operating one switch which at the same time leaves a pair of dipped beams. e. main beam warning lamp does not illuminate when main beam is selected and extinguish when dipped beam is selected. <p>5. A rear registration plate lamp throws direct light to the rear.</p>

66 Direction Indicators and Hazard Warning Lamps

Application

Direction indicators

This inspection applies to all vehicles first used after 1 January 1936 and trailers manufactured from 1 September 1965.

Side repeaters are required on motor vehicles first used from 1 April 1986.

All indicators fitted must work. These must show amber light unless fitted to a vehicle first used before 1 September 1965 when both indicators may show white to the front or red to the rear.

The tell-tale on direction indicators may be audible rather than visual but for hazard warning lamps it must be a flashing light. A tell tale is not required if the operation of one or more indicators on each side can be seen from the driver's seat.

If the flash rate is below 60 times per minute, recheck with the engine running.

A semaphore indicator is acceptable. It must illuminate when in operation, and is not required to flash.

Hazard warning lamps

This inspection applies to all vehicles fitted with hazard warning lamps.

They need not be fitted to vehicles first used before 1 April 1986.

The tell-tale shall be a flashing light which may operate in conjunction with any direction indicator tell-tale, with the ignition on and off.

Where red-neutral direction indicator lenses with an amber bulb are fitted, the assessment made must be against the colour of the light emitted not the colour of the lens.

Some vehicles are fitted with obligatory side marker lamps/indicator side repeater lamps, these remain illuminated when the side lights are switched on. This is not an RfF provided the lamp flashes when required.

If two or more lamps are fitted and the aggregated illuminated area occupies 60% or more of the area of the smallest rectangle circumscribing the illuminated area this should be treated as one lamp.

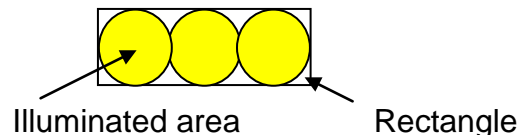

If more than one bulb or LED is fitted in the lamp at least 50% must work.

66 Direction Indicators and Hazard Warning Lamps

Method of Inspection	Reason for Failure
<p>1. Check direction indicators for:</p> <ul style="list-style-type: none"> a. presence, operation, operating on the correct side of a vehicle/trailer, their condition and are visible to the front and rear. b. presence of a side repeater. c. the presence of the lens, its security and condition. d. flashing at between 60 to 120 times a minute. e. a light of the right colour. f. presence of a tell-tale, its operation and can be seen/heard by the driver. g. the rate of flash and illumination is not affected by any other lamp. h. the operation of a semaphore indicator. <p>2. Check hazard warning lamps for:</p> <ul style="list-style-type: none"> a. operation with the engine stopped and the ignition switched off and on. b. all the direction indicator lamps operating simultaneously when switched on by one switch. c. presence of a tell-tale, its operation and it can be seen by the driver. 	<p>1. Direction indicator:</p> <ul style="list-style-type: none"> a. missing, inoperative, operating on the wrong side of a vehicle/trailer, dim or not visible either to the front or to the rear. b. side repeater missing. c. lens missing, insecure or damaged so that it is likely to fall apart. d. does not flash at between 60 to 120 times a minute. e. does not show a light of the right colour. f. tell-tale not fitted, is inoperative or cannot be seen/heard by the driver. g. rate of flash or illumination is affected by any other lamp. h. a semaphore indicator sticking. <p>2. Hazard warning lamp:</p> <ul style="list-style-type: none"> a. does not operate with the engine stopped and the ignition switched off and on. b. all the direction indicator lamps do not operate simultaneously when switched on by one switch. c. tell-tale not fitted, is inoperative or cannot be seen by the driver.

67 Aim of Headlamps

Application

The headlamp aim criterion is applicable to all dipped beam headlamps.

Headlamp beam converters fitted to right hand dipping headlamps which effectively mask/deflect the beam are acceptable provided that the pass criterion is met.

Some vehicles may be fitted with an "in-cab" headlamp adjustment device. If the vehicle is presented for test unladen, the in cab headlamp adjustment device must be set relative to this condition. In all other cases this may be adjusted to enable both headlamps to meet the criteria, however both headlamps must comply with the requirements with the device set in one position.

The headlamp control in the cab is allowed to be used to align the headlamps without failing the vehicle.

Most modern vehicles are fitted with European headlamps. Dipped beam headlamps can be identified from the marking on the lamps. There will be a "C" shown above an "E" or "e" mark.

Repairs must not be carried out during a test however; minor adjustments to the headlamp aim are acceptable.

If the beam pattern is blurred due to condensation and does not show a distinctive cut-off point for the examiner to determine whether the alignment is correct this will be a failure under Reason for Failure 1.

Some vehicles with complex headlamp systems (with the dipped beam and main beam having separate pockets) may be encountered. It is essential that the headlamp aim test equipment is aligned exactly on the centre of the dipped beam pocket. At this point it may not be possible to see a clearly defined headlamp pattern, in order to see the full beam pattern, it may be necessary to move the vehicle closer to the test equipment. Once this has been done, the beam pattern should be clearly visible on the aiming screen. When a full pattern can be seen, the normal assessment of headlamp aim should be followed.

The standards to be applied are shown above the beam patterns likely to be encountered on the following pages.

Heavy Goods Vehicle Inspection Manual

67 Aim of Headlamps	
Method of Inspection	Reason for Failure
<p><u>European checked on Dipped Beam</u> Align the headlamp aim testing equipment to the vehicle in accordance with the manufacturer's instructions.</p>	<ol style="list-style-type: none"> 1. In relation to the 0% Horizontal line, the beam horizontal cut-off line is not between the limits listed below. Headlamp centres up to and including 850mm high Upper limit: All vehicles. 0.5% Lower limit: All vehicles 4.0% Headlamp centres over 850mm high Upper limit: All vehicles. 1.25% Lower limit: All vehicles 4.0% 2. The beam image contains a "Kick up" that is not visible on the screen 3. White light shows in the zone formed by the 0% vertical and 0.5% horizontal lines

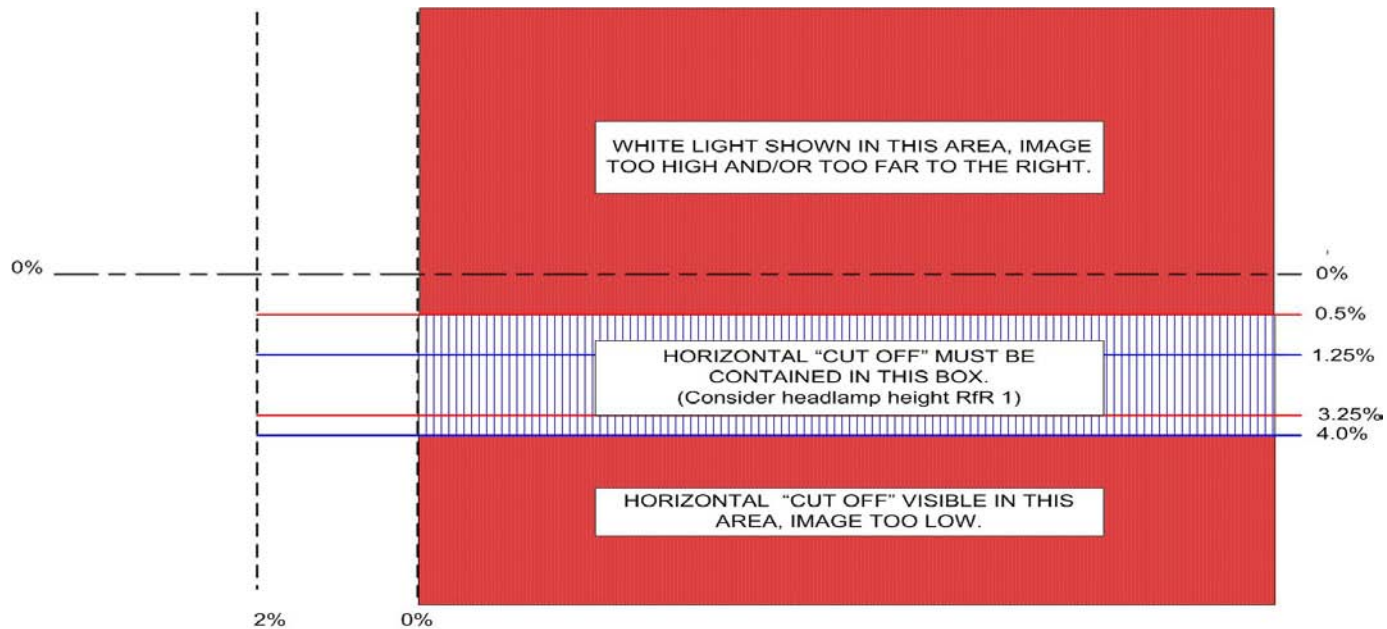

67 Aim of Headlamps

Method of Inspection	Reason for Failure
<p><u>British American Checked on Dipped Beam</u></p> <p>Align the headlamp aim testing equipment to the vehicle in accordance with the manufacturer's instructions.</p>	<p>4. In relation to the 0% Horizontal line, the upper edge of the "Hot Spot" is not between the limits listed below.</p> <p>All headlamp heights Upper limit: All vehicles. 0% Lower limit: All vehicles 4.0%</p> <p>5. The right hand edge of the "Hot Spot" is to the right of the vertical 0% line, or more than 2% to the left of it.</p> <p>6. All - A Headlamp dips to the right. (See note in Applications).</p>

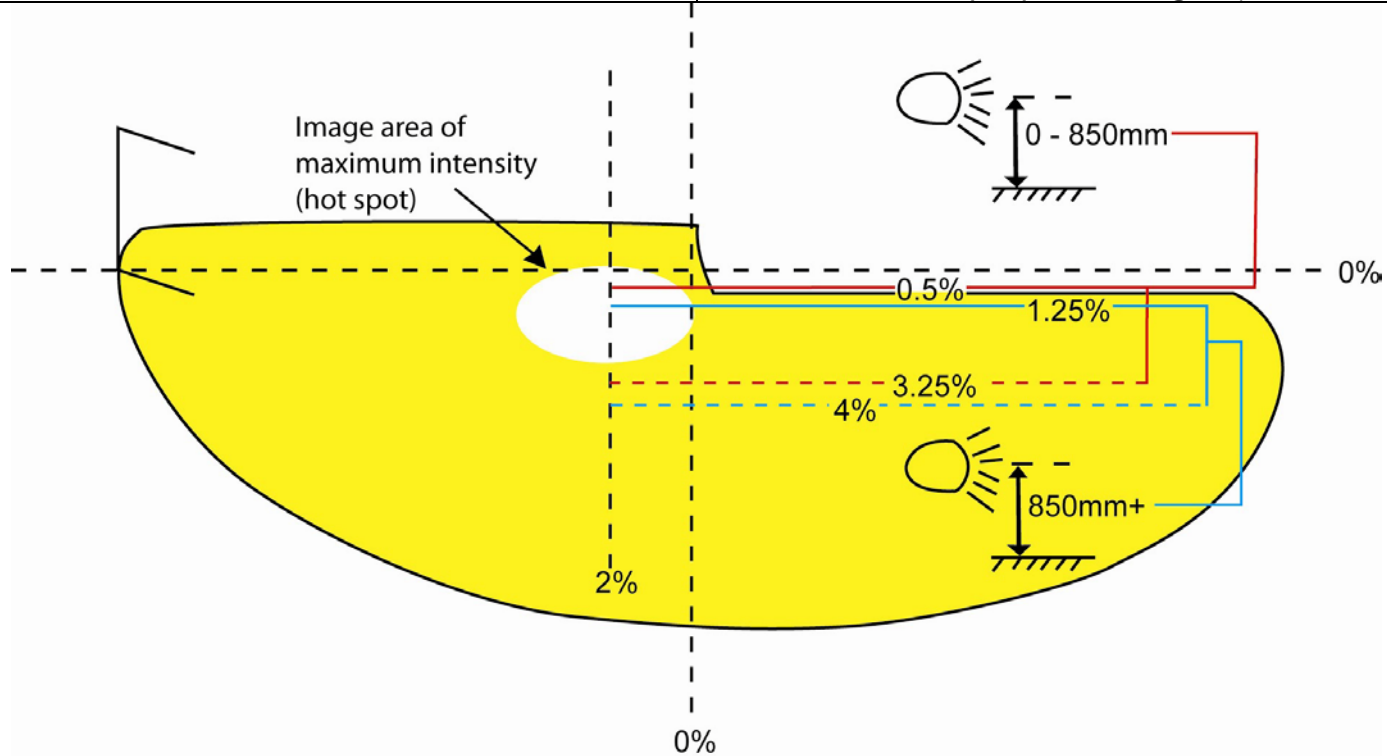

67 Aim of Headlamps	
Method of Inspection	Reason for Failure
<p><u>British American Checked on Main Beam</u></p> <p>Align the headlamp aim testing equipment to the vehicle in accordance with the manufacturer's instructions.</p>	<p>7. In relation to the 0% Horizontal line, the centre of the "Hot Spot" is not between the limits listed below.</p> <p>Headlamp centres up to and including 850mm high Upper limit: All vehicles. 0% Lower limit: All vehicles. 2.0%</p> <p>Headlamp centres over 850mm high Upper limit: All vehicles. 0% Lower limit: All vehicles. 2.75%</p> <p>8. In any case the centre of the "Hot Spot" is to the right of the vertical 0% line or more than 2% to the left of it.</p> <p>9. A Headlamp dips to the right. (See note in Applications).</p>

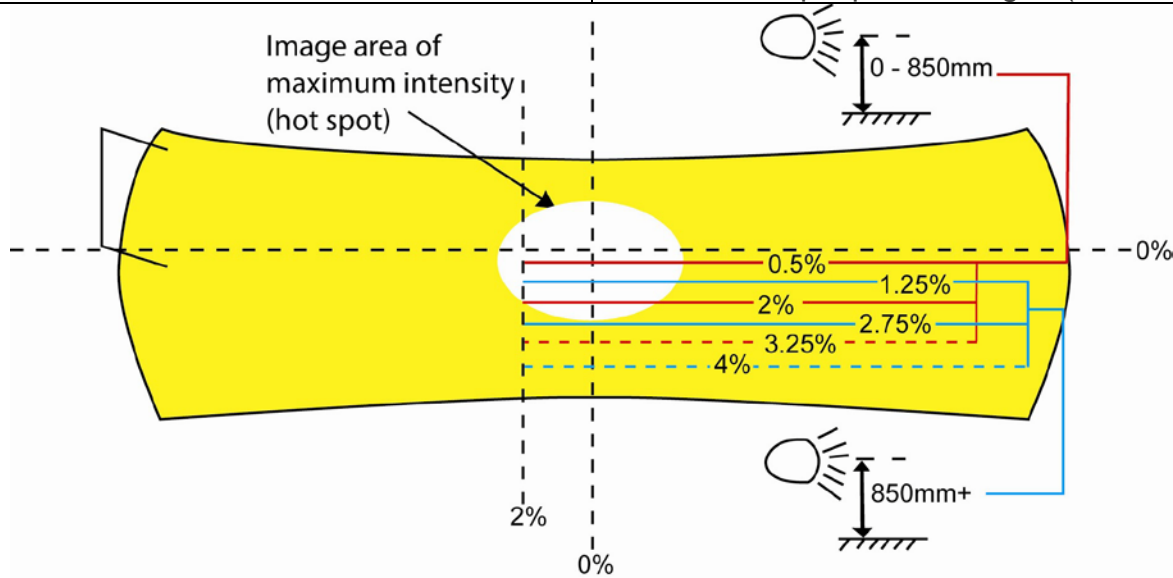

71 Service Brake Performance

Application

This inspection applies to all vehicles and trailers.

To avoid damage to the vehicle or the equipment, no tyre must be obviously underinflated.

In the case of vehicle and trailer combinations, each unit of the combination is considered separately.

In this section of the manual, the term "drum" includes "discs".

Attention must be paid to Hybrid Electric Vehicles (HEVs). Due to the nature of the control systems some vehicles can not be tested on the Roller Brake Tester and must receive a decelerometer brake test.

Some vehicles have a regenerative braking system connected to the service brake system. If the regenerative system cannot be disconnected from the service brake, a decelerometer brake test is required. If the regenerative system can be disconnected and the vehicle control system allows a roller brake test this must be carried out.

If you are in any doubt whether a vehicle can be roller brake tested and if the presenter does not know, contact T.S.S. Swansea.

Brake testing HEVs, with a regenerative brake system must be appropriately charged (appropriately in this context means the red warning light showing there is a defect is not illuminated).

Vehicles that require decelerometer testing are:

Mercedes Axor Bluetec Hybrid.

Vehicles that can be tested on the brake rollers are:

Mitsubishi Canter – Transmission must be in neutral.

Smiths Electical – Light vehicles ignition needs to be turned on and neutral selected.

Heavy vehicles, High voltage system needs to be on and neutral selected.

71 Service Brake Performance

Application

Before failing a vehicle for binding, examiners should be aware that drag at a wheel may be recorded which is not necessarily due to brakes, but may be due to transmission drag, or by the deformation of the tyres on the rollers, which on a fully laden 10,000 kg axle could be as much as 250kg. A recorded bind in excess of 4% of the measured axle weight should be considered a Reason for Failure.

Brake effort fluctuation of more than 70% of the higher brake effort recorded at a steady pedal pressure is a Reason for Failure. For ease of calculation if the higher brake effort divided by the lower brake effort is greater than 3.3 this is a Reason for Failure.

The highest reading obtained should be recorded when the brake force from any one wheel is fluctuating in a regular manner between two readings, (e.g.1850kg should be recorded where the needle reading was fluctuating between 1750kg and 1850kg).

Using the maximum recorded forces for each wheel on an axle, check that the braking effort from any wheel is 70% or more of the effort of the other wheel on the same axle. When wheels lock, this Reason for Failure will not apply if both the wheels lock, or if one wheel locks and the braking effort of the locked wheel is less than that of the other.

Little or no brake effort recorded at any road wheel should be considered a Reason for Failure if less than 5% of the measured axle weight is not attained.

In the case of a motor vehicle the Brake data cards should be used wherever possible.

Locked Wheels

If more than half the number of wheels lock, the specified brake effort can be considered to be met. On a motor vehicle where not more than half the wheels lock, where available the allowances contained in any data card information must be taken into account. Wheels on the verge of locking are not acceptable, they must fully lock.

Load Simulation

To obtain a higher reading for brake effort than is possible with the vehicle as presented, use a load simulator to apply a load whenever practicable, or have the vehicle loaded. Certain three axle tractor units can only be satisfactorily brake tested when presented coupled to a laden semi-trailer. Where this is the case stations must insist that the combination is suitably loaded so that axle weights are higher than 65% of the design axle weight.

71 Service Brake Performance

Application

Vehicles fitted with Load Sensing valves

Where possible the load simulator should be used to apply a load, so that the valve operates. Where it is not possible to apply a load, the driver may be allowed to temporarily disconnect the valve linkage, or otherwise by-pass the valve, immediately before the brake test, to allow the required braking force to be achieved. The driver must ensure that the valve has been restored to its proper working condition before the vehicle leaves the Testing Station. Failure to do so may break the law.

Deceleration Test

If the vehicle cannot be roller brake tested, or for any other reason a decelerometer test is required, proceed as MOI.

Double Drive Rear Axle - Interposing Differential

Before carrying out a brake test on a vehicle fitted with a double drive rear axle it will be necessary to establish whether an interposing differential is fitted or not. A check can be carried out by using the R.B.T. in the following manner:

- Instruct the driver to release all brakes and ensure the gear lever is in the neutral position.
- Start the nearside roller in the forward direction and observe the offside wheel, if this turns in the reverse direction no interposing differential is fitted and the brake test will need to be carried out as explained in paragraphs # # below.
- If the running of one wheel has no effect on the other on the same axle, then the test can be conducted as for a single drive axle.

If no interposing differential is fitted carry out the test as follows :

- Place chocks at front and rear of the wheels of the front axle.
- Press and hold on N/S forward and O/S reverse button simultaneously, the wheel under test must turn forward and the opposite wheel on the same axle must turn in the reverse direction.
- Carry out the brake test as described above.

Do not run the rollers any longer than necessary to obtain an accurate reading.

Release both buttons together:

- Change direction of rollers and carry out test on the O/S wheel brake.
- Repeat the above procedure for all brake systems at this axle.
- Move the vehicle forward and carry out the same procedure for the second driving axle.

A transmission brake fitted to a vehicle of this type can not be tested on a roller brake tester.

71 Service Brake Performance

Application

Drop off of brake effort

If drop off of brake effort is noted during the roller brake test, first confirm that it is drop off and not simply due to the driver releasing the brake pedal or brake effort fluctuation. If drop off is confirmed it will be appropriate to consider a failure under Inspection Manual item 59.

Vehicles with full power hydraulic braking systems

If necessary to confirm compliance with Test Item 34 for vehicles with full powered hydraulic braking systems the following additional tests should be made:

- Position the vehicle so that each axle in turn is located on the roller brake tester.
- With the engine stopped, deplete the brake pressure by repeated application of the service brake pedal until commencement of operation of the low pressure warning device.
- With the roller brake test machine driving the wheels of each axle in turn;
 - a. apply the service brake slowly and check for first indications of braking effort. Release brake immediately. Re-apply the brake, check for a second time for indication of braking effort, and release immediately.
 - b. repeat test sequence for each axle in turn.

Skeletal vehicles with an empty body fitted should be treated as unladen.

For vehicles with Hydrostatic drives if the brake performance is not met on the brake rollers, perform a decelerometer test before making a decision on the pass fail requirements. Prior to roller brake testing any vehicle with hydrostatic drive and a transmission parking brake it may be necessary when the wheels are in the roller set to select the vehicles mode which disengages/bypasses the hydrostatic drive. Engaging this mode will prevent any hydrostatic retardation showing as excessive levels of bind.

With some DTP numbers the roller brake tester may request you check for brake effort drop off, you need to establish whether the vehicle has air over hydraulic brakes, if it has do the drop off test, if the system is full air ignore the request for the drop off test.

Ensure that the air suspension on tag/pusher axles that may have been jacked up are inflated should there be a problem achieving the brake efficiency for these axles (the inflation should only be done under supervision of station staff).

Switching the ignition off on vehicles equipped with EBS is to be taken as the same as vehicles having their LSV disconnected. **Tri axle trailers equipped with Knorr Bremse EBS/ABS** should be driven to the RBT and not allowed to switch the ignition off while stationary on the brake rollers, if this circumstance occurs the following procedure must be followed:

- A.** Make sure the ignition is switched off, **B.** apply the parking brake, **C.** apply the footbrake, **D.** switch the ignition on, **E.** start the engine, **F.** release the foot brake and parking brake and carry out a full brake test on all axles using the appropriate unladen or laden tri axle trailer criteria.

71 Service Brake Performance

Application

Vehicles and Trailers with Electronic Braking System (EBS)

1. Testing Vehicles with EBS Braking Systems

Vehicles with EBS that have load sensing on the front axle. If the minimum front axle brake figure is not achieved because the load sensing valve is regulated by the load imposed on the rear axle/s, re-test the front axle brakes in the following manner.

- a) Build up the air reservoirs and stop the engine.
- b) Switch the engine off to deactivate the load-sensing valve.
- c) Carry out the brake performance test.

Switching the ignition off on a vehicle with EBS has the effect of by passing the load-sensing valve.

2. Testing Trailers With WABCO Trailer EBS (Electronic Braking System)

How to recognise EBS.

- No ABS warning lamp on the headboard.
- With the ignition on, definitive solenoid clicks from the trailer on each application of the footbrake should be heard.
- Plate with the heading "WABCO Trailer EBS" on the front of the trailer and a pictogram showing an X through LSV and ABS.
- ISO 7638 electrical connector fitted in addition to the electrical connector for the lights.
- Last digit of the DTp Reference number is an '8'. The brake computer has not been programmed to accept an 8 so this must be replaced with 7 as the last digit.

When presented, the tractor unit must be compatible with the trailer and have a warning lamp to indicate that trailer ABS is working (this may be a combined ABS/EBS warning light).

If presented with a compatible EBS tractor unit, if the red line is dropped, **the brakes may not come on**. To apply the brakes disconnect the ISO 7638 electrical connection. Ensure that the handbrake is applied on the tractor unit before disconnecting the red line and that safe working practices are followed.

Brake Testing

Irrespective of whether the trailer is laden or unladen, before commencing the brake test, the EBS Processor must be conditioned (**not to be used for Knorr bremsse ABS/EBS equipped trailers see note on previous page**) this is done by:

- a) Putting the first axle of the trailer in the RBT.
- b) Switch off the engine/ignition and ensure no brake is applied.
- c) Restart engine.
- d) Continue the brake test as normal. This procedure only needs to be carried out once. The system will reset when the trailer is driven at a speed greater than 7 KM/H.

Failure to do this will stop the Load Sensing Valve working, i.e. a full pressure brake reading on every application.

Heavy Goods Vehicle Inspection Manual

71 Service Brake Performance

Application

SERVICE BRAKE EFFICIENCY REQUIREMENTS

Motor Vehicles	2 Axle Rigid vehicle first used before 1 January 1968 and with no manufacturer's plate	Rigid vehicle with more than 2 axles or any articulated tractor first used before 1 January 1968 and with no manufacturer's plate	Any other vehicle	
Specified Efficiency	45% DGWW	40% DGWW	50% DGWW	
Semitrailers and centre axle draw-bar trailers	Manufactured before 1 January 1968 with GVW 6100 kg or more	Manufactured before 1 January 1968 with GVW less than 6100 kg	Manufactured from 1 January 1968 to 30 September 1982	Manufactured from 1 October 1982
Specified Efficiency	35% DTAW	32% DTAW	40% DTAW	45% DTAW
Full drawbar trailers	Manufactured before 1 January 1968	Manufactured from 1 January 1968 to 30 September 1982	Manufactured from 1 October 1982	
Specified Efficiency	40% DGWW	50% DGWW	45% DGWW	

DGWW = Design Gross Vehicle Weight.

DTAW = Design Total Axle(s) Weight.

71 Service Brake Performance

Method of Inspection	Reason for Failure
<p>1. Roller Brake Test Machines Operating With a Computer Controlled Brake Test Follow the sequence of instructions as displayed and prompted on screen. On completion of the test a result sheet is printed indicating the test result.</p> <p>2. All Roller Brake Test Machines</p> <ul style="list-style-type: none"> a. check no brake on any wheel is binding. b. apply brake slowly and check for abnormal time lag in operation of the brake on any wheel. c. on a (vehicle) steered axle with the service brake applied at a steady pedal pressure, check there is no indication of brake effort fluctuations regularly with each revolution of the road wheel. <p><i>The ovality check does not apply to trailers.</i></p> <ul style="list-style-type: none"> d. continue to apply the brake until the road wheel is just at the point of slip relative to the rollers, or until the service brake is fully applied, whichever occurs first. Note the maximum recorded brake effort. <p>3. Decelerometer test. Set the decelerometer on the vehicle in accordance with the instrument manufacturer's instructions. At a speed of approximately 20mph, have the service brake applied, note the reading on the decelerometer and whether the vehicle deviates from a straight line.</p>	<p>1. Roller Brake Test Machines Operating With a Computer Controlled Brake Test As computer prompt instructions (unless overruled).</p> <p>2. All Roller Brake Test Machines</p> <ul style="list-style-type: none"> a. a brake on any wheel binding. b. brake mechanism on any wheel sticking, indicated by an abnormal time lag before, an increased reading is obtained. c. with service brake applied at a steady pedal pressure, the indication of brake effort fluctuates regularly with each revolution of the road wheel, on a steered axle, so much that the ovality of any brake drum is obvious. A fluctuation of recorded reading in excess of 70%, between highest and lowest indicated readings is to be considered a Reason for Failure. d. With the service brake fully applied: <ul style="list-style-type: none"> *i there is little or no brake effort at any wheel. *ii braking effort from any wheel on an axle is less than 70% of the brake effort from another wheel on the same axle. *iii the specified brake effort is not met. <p>*3. Decelerometer test. The braking efficiency recorded by decelerometer is below the specified efficiency for the vehicle under test, or the vehicle deviates appreciably from a straight line.</p>

72 Secondary Brake Performance

Application

This inspection applies to all motor vehicles where the designated secondary brake operates independently of the service brake.

The notes relating to Electrical and Hybrid Electrical Vehicles under Inspection 71 also apply to this inspection particularly where the designated secondary brake is the parking brake, refer to these notes before deciding what type of brake test should be performed.

To avoid damage to the vehicle or the equipment, no tyre must be obviously under inflated.

There may be occasions where the specified brake effort is met but, if the brake effort from any wheel on an axle is one third or less than the brake effort from another wheel on the same axle, it may be necessary to consider Reason for Failure 1a, 1b or 5a of Inspection 59. The notes relating to Locked Wheels and Load Simulation under Inspection 71 also apply to this inspection.

SECONDARY BRAKE EFFICIENCY REQUIREMENTS

Motor Vehicles	2 Axle Rigid vehicle first used before 1 January 1968 and with no manufacturer's plate	Rigid vehicle with more than 2 axles or any articulated tractor first used before 1 January 1968 and with no manufacturer's plate	Any other vehicle
Specified Efficiency	20% DGWW	15% DGWW	25% DGWW

DGWW = Design Gross Vehicle Weight.

72 Secondary Brake Performance

Method of Inspection	Reason for Failure
<p>1. Roller Brake Test Machines Operating With a Computer Controlled Brake Test Follow the sequence of instructions as displayed and prompted on screen. On completion of the test a result sheet is printed indicating the test result.</p> <p>2. All Roller Brake Test Machines For each road wheel in turn apply the secondary brake until the:</p> <ul style="list-style-type: none"> a. road wheel is just at the point of slip relative to the rollers, or b. the secondary brake is fully applied, whichever occurs first. <p>Note the maximum braking effort indicated from the brake of each road wheel.</p>	<p>1. Roller Brake Test Machines Operating With a Computer Controlled Brake Test As computer prompt instructions (unless overruled.)</p> <p>2. All Roller Brake Test Machines With the secondary brake fully applied:</p> <ul style="list-style-type: none"> a. there is little or no braking effort at any wheel equipped with a brake operated by the secondary brake system. *b the specified brake effort is not met.

73 Parking Brake Performance

Application

This inspection applies to all vehicles and trailers.

The notes relating to Electrical and Hybrid Electrical Vehicles under Inspection 71 also apply to this inspection, refer to these notes before deciding what type of brake test should be performed.

To avoid damage to the vehicle or the equipment, no tyre must be obviously under-inflated, and the brake rollers should not be continuously applied.

It is necessary to use an applied brake method of testing as described in the MOI, except for vehicles with transmission parking brakes, or if the R.B.T. is not capable of carrying out an applied test. In these cases it is necessary to use the ALTERNATIVE method as described in the MOI.

There may be occasions where the specified brake effort is met but, if the brake effort from any wheel on an axle is one third or less than the brake effort from another wheel on the same axle, it may be necessary to consider Reason for Failure 1a, 1b or 5a of Inspection 59 depending on the operation controls of the system (e.g. cable, rods, air or hydraulic). The notes relating to Locked Wheels and Load Simulation under Inspection 71 also apply to this inspection.

If a vehicle has had its DGTW reduced, the DTp number may not reflect this new weight. It may be necessary to calculate the park brake performance for the new DGTW at 12% or the DGVW at 16% whichever is the greater.

If a trailer has more than one parking brake fitted, each park brake must meet the minimum standard of efficiency.

Where a trailer has been permanently attached to a towing vehicle, it is still mandatory to have a park brake on the trailer.

73 Parking Brake Performance

Application

PARKING BRAKE EFFICIENCY REQUIREMENTS			
Motor Vehicles	Any vehicle first used before 1 January 1968	Any vehicle first used from 1 January 1968 apart from a Type Approved articulated tractor or drawing vehicle	A Type Approved* articulated tractor or drawing vehicle
Specified Efficiency	–	16% DGWW	16% DGWW 12% DGTW
Semi-trailers and Draw-bar trailers	Manufactured before 1 January 1968	Any other trailer	
Specified Efficiency	–	16% DGWW	

DGWW = Design Gross Vehicle Weight.

DGTW = Design Gross Train Weight.

*Type Approved - Manufactured from 1 October 1982 and first used from 1 April 1983 and has been issued with a Type Approval Certificate of Conformity, a Ministers Approval Certificate or a Type Approval Certificate issued by an EU member state.

73 Parking Brake Performance

Method of Inspection	Reason for Failure
<p>1. Roller Brake Test Machines Operating With a Computer Controlled Brake Test Follow the sequence of instructions as displayed and prompted on screen. On completion of the test a result sheet is printed indicating the test result.</p> <p>2. Applied Brake Test on a Roller Brake Tester Apply the parking brake fully and release any power assistance. The service brake may be used at this stage in setting the park brake. Start each brake machine roller in turn and note the maximum braking effort indicated for each wheel in turn.</p> <p>3. Alternative method With the roller brake test machine driving each road wheel in turn, apply the parking brake slowly until each road wheel is just at the point of slip relative to the rollers, or until the parking brake is fully applied, whichever occurs first. Note the braking maximum effort indicated from the brake of each road wheel.</p> <p>Transmission Parking Brakes. If the parking brake is a transmission brake, all wheels on the same axle braked by it must be driven by the roller test machine at the same time.</p> <p>4. Transmission Parking Brakes Roller Brake Test. With the roller brake machine driving both road wheels together, instruct the driver to apply the transmission brake as slowly as possible, constantly keeping the release button depressed, until any road wheel is just at the point of slip relative to the rollers, then release the brake quickly. Note the braking effort indicated from the brake of each wheel.</p>	<p>1. Roller Brake Test Machines Operating With a Computer Controlled Brake Test As computer prompt instructions (unless overruled).</p> <p>2. Applied Brake Test on a Roller Brake Tester With the parking brake fully applied: a. there is little or no braking effort at any wheel equipped with a brake operated by the parking brake system. *b. the specified brake effort is not met.</p> <p>3. Alternative method With the parking brake fully applied: a. there is little or no braking effort on any wheel equipped with a parking brake, or *b. the specified brake effort is not met.</p> <p>4. Transmission Parking Brakes Roller Brake Test. With the transmission parking brake full applied: a. there is little or no brake effort, or *b. the specified brake effort is not met.</p>

74 Other Dangerous Defects

Application

This applies to all vehicles and trailers.

Whilst this manual attempts to be comprehensive and cover all reasons for failure which could be dangerous it is inevitable that due to changes in design, or other reasons, from time to time dangerous defects may be found which are not described in any of the reasons for failure in the other items in this manual. If a defect of this type is found, which is such that the use of the vehicle on the road would involve a danger of injury to any person, this would justify a failure under this item. In addition it would be appropriate to issue an Immediate Prohibition for a defect of this nature.

It is not intended that this item should be used as a matter of routine but only for exceptional cases. If a failure is recorded under this item full details must be shown on the test card and a copy should be sent to Testing and Support Services so that any trends can be noted and amendments made to the manual if necessary.

Method of Inspection

Reason for Failure

**1. A defect not described elsewhere in the manual such that the use of the vehicle or trailer on the road would involve a danger of injury to any person.